

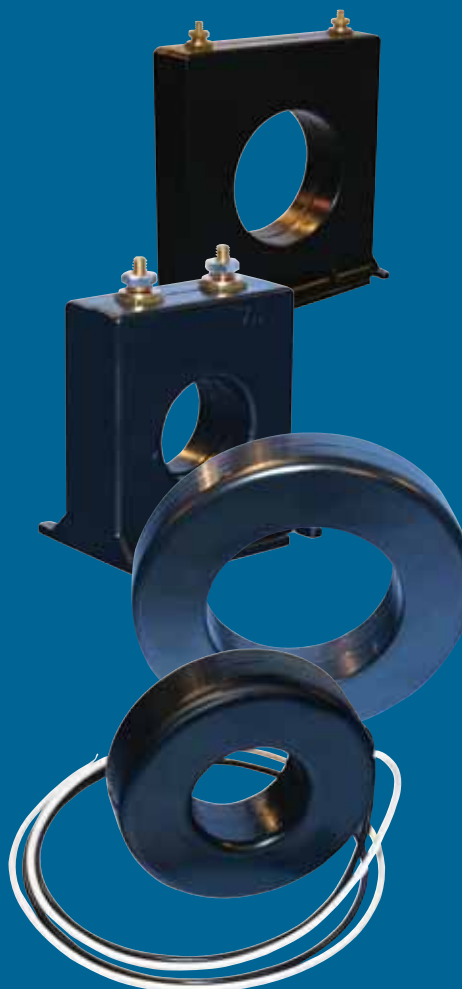







Energy Division

Crompton Instruments Current and Voltage Transformers

Crompton Instruments

Current and Voltage Transformers



Contents	Page
 Current Transformer for Metering and Instrumentation	3
 Current Transformer for Metering and Relaying	15
 3 Phase Current Transformers	79
 Specific Mounting (Breaker Type) Current Transformers	91
 Wound Primary Current Transformers	103
 Voltage Transformers	109
 Voltage Transformers Control Power Transformers	121
 Technical Data	131

Note: All dimensions are in inches

Current Transformers

For Metering and Instrumentation
600V Current Transformers Non-ANSI Rated Window Type

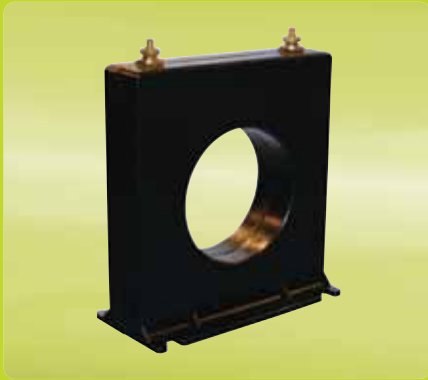

Contents

Window Sizes

0.56



4

0.50, 0.94, 1.25



5

0.56, 1.25, 2.00



6

0.54



7

1.00, 1.05, 1.13



8

1.56



9

1.56



10

2.06



11

2.06



12

2.50



13

3.00



14

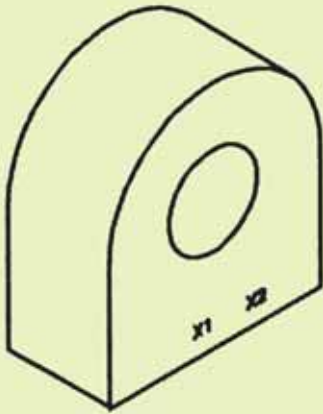

Model 13

Application:

For current to voltage conversion by use of a loading resistor.

Frequency:

50-400Hz

Insulation Level:

600 Volts, 10kV BIL full wave

Continuous Thermal Current Rating Factor:

200A at 30°C amb,
120A at 55°C amb

- Approximate weight: 0.1-0.2 lbs

Approvals



Model 13

Window Diameter 0.56"

This lightweight, miniature current transformer is suitable for direct mounting on printed circuit boards. The graphs below illustrate the voltage output capacity of each, and over the ranges shown, will maintain a $\pm 3\%$ linearity.

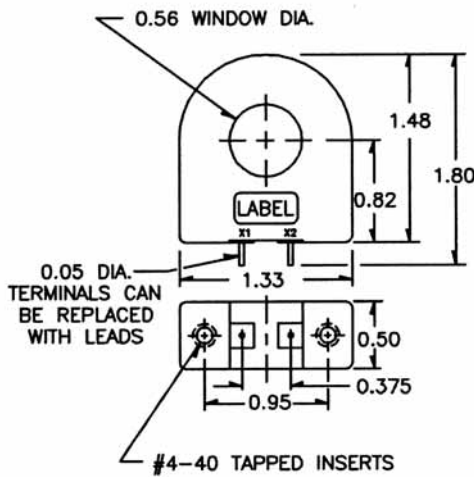

Typical Performance Characteristics

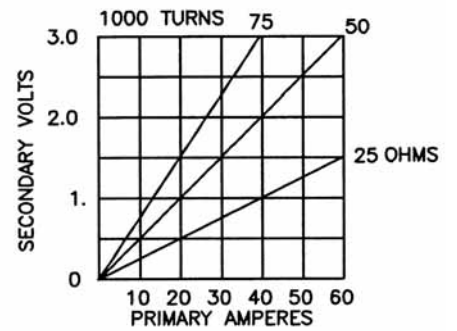

Models 14, 15, 16

Window Diameter 0.50", 0.94", 1.25"

Note: Model 15 available now.

Models 14 and 16 available mid-September 2002.

Catalogue Number	Current Ratio	Accuracy at 60Hz	Burden VA at 60Hz	Dim 'A'
14**-500	50:5	±1.5%	2.5	
14**-600	60:5	±1.5%	2.5	
14**-750	75:5	±1.5%	2.5	0.50
14**-800	80:5	±1.0%	2.5	
14**-101	100:5	±1.0%	3.0	
15**-500	50:5	±1.5%	2.0	
15**-600	60:5	±1.5%	2.0	
15**-750	75:5	±1.5%	2.5	
15**-800	80:5	±1.0%	2.0	
15**-101	100:5	±1.0%	2.0	0.94
15**-121	120:5	±1.0%	3.0	
15**-1250	125:5	±1.0%	4.0	
15**-151	150:5	±1.0%	5.0	
15**-1750	175:5	±1.0%	10.0	
15**-201	200:5	±1.0%	12.5	

Catalogue Number	Current Ratio	Accuracy at 60Hz	Burden VA at 60Hz	Dim 'A'
16**-500	50:5	±2%	1.5	
16**-600	60:5	±2%	1.5	
16**-750	75:5	±2%	3.0	
16**-800	80:5	±2%	3.0	
16**-101	100:5	±1%	3.0	
16**-121	120:5	±1%	4.0	1.25
16**-1250	125:5	±1%	5.0	
16**-151	150:5	±1%	6.0	
16**-1750	175:5	±1%	7.0	
16**-201	200:5	±1%	8.0	
16**-251	250:5	±1%	10.0	
16**-301	300:5	±1%	10.0	
16**-401	400:5	±1%	15.0	

**** NOTE:** When ordering, prefix Catalogue Number with model designation required, i.e. 15SFT-151.



SFT Models

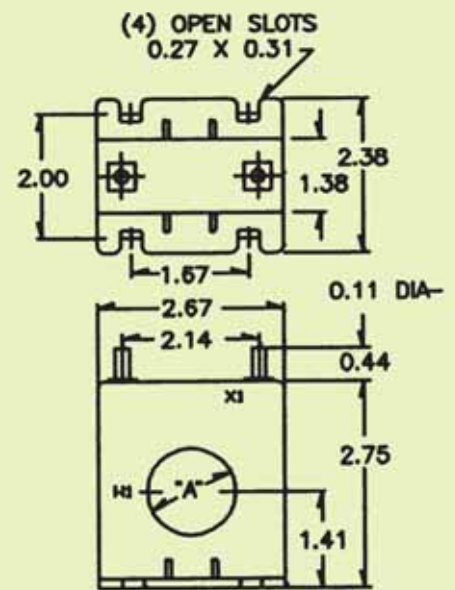

Application:

With ammeters, energy management systems and instrumentation.

Frequency:

5-400Hz

Insulation Level:

- 600 Volts, 10kV BIL full wave
- Terminals are brass studs No. 8-32 with one flat washer, lockwasher and regular nut
- Flexible leads are UL 1015 105°C, CSA approved, #16 AWG, 24" long
- Non-standard length to be specified
- SFT case style also available as SFL with leads
- Approximate weight: 0.9 lbs

Approvals



Models 63A, 63B, 63C

Window Diameter 0.56", 1.25", 2.00"

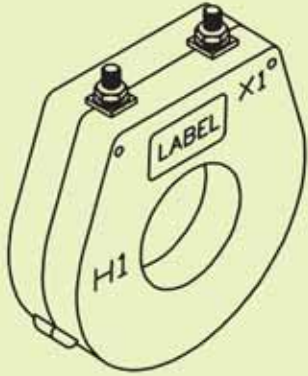

Model 63A

Catalogue Number	Current Ratio	Accuracy at 60Hz	Burden VA at 60Hz	Dim 'A'
63A-500	50:5	± 2%	2.5	
63A-600	60:5	± 2%	2.5	
63A-750	75:5	± 1%	2.5	0.56
63A-800	80:5	± 1%	2.5	
63A-101	100:5	± 1%	2.5	

Model 63B

Catalogue Number	Current Ratio	Accuracy at 60Hz	Burden VA at 60Hz	Dim 'A'
63B-500	50:5	± 2%	1.5	
63B-750	75:5	± 2%	2.5	
63B-101	100:5	± 1%	2.5	
63B-1250	125:5	± 1%	2.5	
63B-151	150:5	± 1%	3.0	1.25
63B-1750	175:5	± 1%	4.0	
63B-201	200:5	± 1%	5.0	
63B-251	250:5	± 1%	6.0	
63B-301	300:5	± 1%	5.0	

Model 63C

Catalogue Number	Current Ratio	Accuracy at 60Hz	Burden VA at 60Hz	Dim 'A'
63C-500	50:5	± 3%	1.0	
63C-101	100:5	± 1%	1.0	
63C-151	150:5	± 1%	2.0	
63C-201	200:5	± 1%	4.0	
63C-2250	225:5	± 1%	4.0	2.00
63C-251	250:5	± 1%	5.0	
63C-301	300:5	± 1%	6.0	
63C-401	400:5	± 1%	7.5	
63C-501	500:5	± 1%	10.0	
63C-601	600:5	± 1%	10.0	

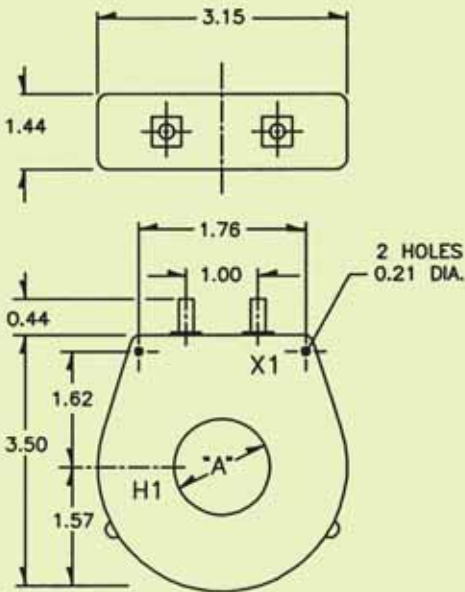

Application:

With ammeters, wattmeters, and cross current compensation.

Frequency:

50-400Hz

Insulation Level:

- 600 Volts, 10kV BIL full wave
- Terminals are brass studs No. 8-32 with one flat washer, lockwasher and regular nut
- Approximate weight: 2.0 lbs

Approvals



Model 1A and 1B

Window Diameter 0.64"

Application:

With ammeters, energy management systems and instrumentation.

Frequency:

50-400Hz

Insulation Level:

600 Volts, 10kV BIL full wave

- Flexible leads are UL 1015 105°C, CSA approved #16 AWG, 24" long.
- Non-standard length to be specified.
- 1 Amp and other secondary currents available upon request.
- Approximate weight:
Model 1A: 0.42 lb
Model 1B: 0.59 lb

Approvals



Catalogue Number	Current Ratio	Accuracy at 60Hz	Burden VA at 60Hz
1A-500	50:5	± 2%	1.0
1A-600	60:5	± 1%	2.0
1A-750	75:5	± 1%	2.0
1A-800	80:5	± 1%	2.0
1A-101	100:5	± 1%	2.5
1A-121	120:5	± 1%	3.0
1A-1250	125:5	± 1%	3.0
1A-151	150:5	± 1%	4.0
1A-201	200:5	± 1%	5.0
1A-251	250:5	± 1%	7.5

Catalogue Number	Current Ratio	Accuracy at 60Hz	Burden VA at 60Hz
1B-500	50:5	± 2%	1.0
1B-600	60:5	± 1%	2.0
1B-750	75:5	± 1%	2.5
1B-800	80:5	± 1%	3.0
1B-101	100:5	± 1%	4.0
1B-121	120:5	± 1%	5.0
1B-1250	125:5	± 1%	5.0
1B-151	150:5	± 1%	7.5
1B-201	200:5	± 1%	10.0
1B-251	250:5	± 1%	12.5

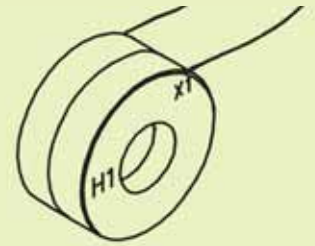
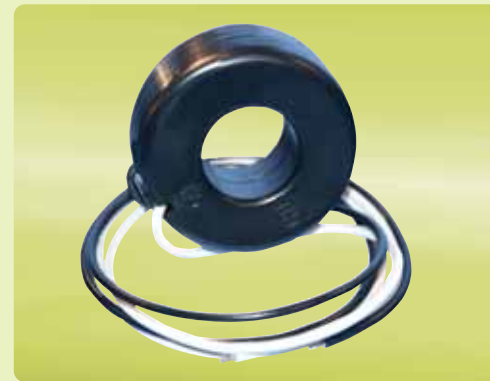

Model 1A

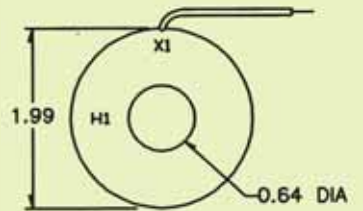
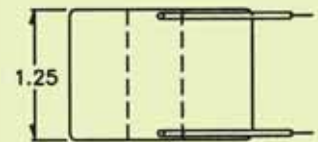

Model 1B

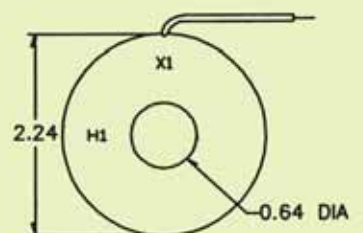
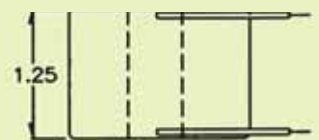



Model 2

Window Diameter 1.0", 1.05", 1.13"

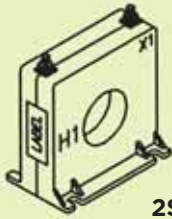

2SFT

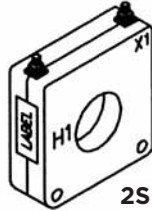
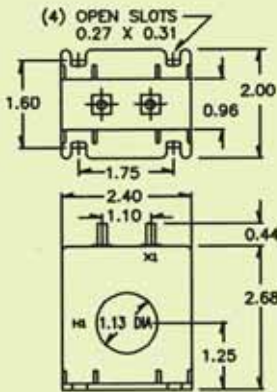

2SHT

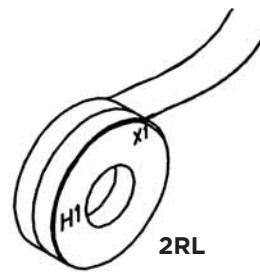
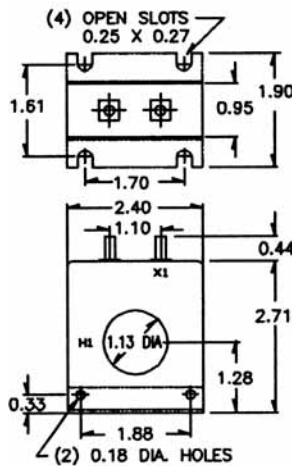

2RL

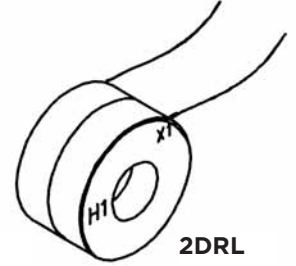
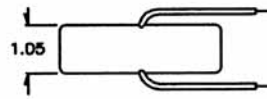

2DRL

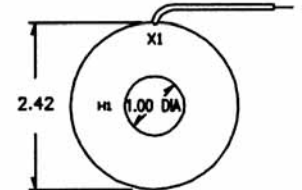
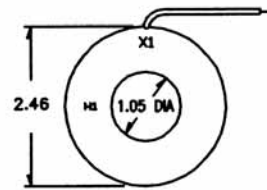
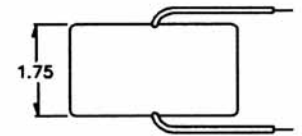

Application:

Generally for ammeter use only.

Frequency:

50-400Hz

Insulation Level:

600 Volts, 10kV BIL full wave

Rating Factor:

2.0 @ 30°C amb

- Flexible leads are UL 1015 105°C, CSA approved #16 AWG, 24" long
- Non-standard length to be specified
- Terminals are brass studs No. 8-32 UNC with one flat washer, lockwasher and regular nut
- SHT and SFT case styles also available as SHL and SFL with leads
- Mounting bracket kit when required for Model 2SHT
- Approximate weight: 0.5 lb

Approvals



UL 257877

CSA 223647

Catalogue Number	Current Ratio	Models 2SFT, 2SHT, 2RL		Model 2DRL	
		Accuracy at 60Hz	Burden VA at 60Hz	Accuracy at 60Hz	Burden at 60Hz
2**-500	50:5	± 3%	2.0	± 2%	1.5
2**-600	60:5	± 2%	2.0	± 1%	2.5
2**-750	75:5	± 2%	2.0	± 1%	3.5
2**-800	80:5	± 2%	2.0	± 1%	4.0
2**-101	100:5	± 1%	2.0	± 1%	5.0
2**-121	120:5	± 1%	2.5	± 1%	5.0
2**-1250	125:5	± 1%	2.5	± 1%	5.0
2**-151	150:5	± 1%	4.0	± 1%	8.0
2**-201	200:5	± 1%	4.0	± 1%	10.0
2**-251	250:5	± 1%	6.0	± 1%	12.5
2**-301	300:5	± 1%	8.0	± 1%	15.0
2**-401	400:5	± 1%	10.0	± 1%	20.0

*NOTE: When ordering, prefix Catalogue Number with model designation required, i.e. 2SFT-301, 2RL-301 or 2DRL-301, etc.

Model 5

Window Diameter 1.56"



5SFT

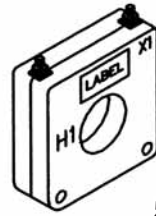

5SHT

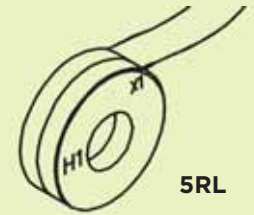
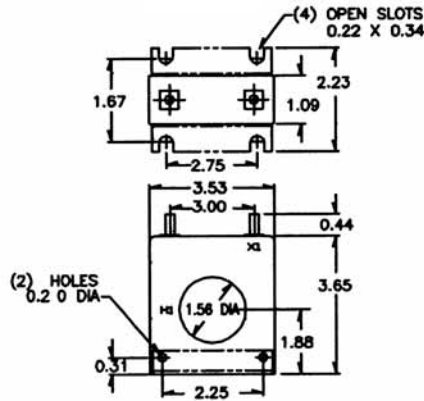
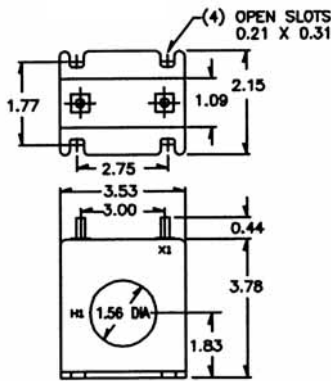

5RL

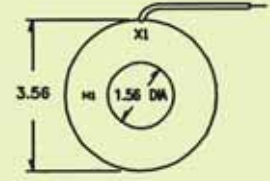
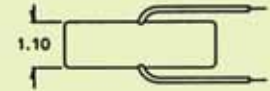

Application:

With ammeters, wattmeters and cross current compensation.

Frequency:

50-400Hz

Insulation Level:

- 600 Volts, 10kV BIL full wave
- Flexible leads are UL 1015 105°C, CSA approved #16 AWG, 24" long
- Non-standard length to be specified
- Terminals are brass studs No. 8-32 UNC with one flat washer, lockwasher and regular nut
- SHT and SFT case styles also available as SHL and SFL with leads
- Mounting bracket kit when required for Model 5SHT
- Approximate weight: 1.0 lb

Catalogue Number	Current Ratio	Accuracy at 60Hz	Burden VA at 60Hz
5**-500	50:5	± 2%	1.0
5**-750	75:5	± 2%	1.5
5**-101	100:5	± 2%	2.0
5**-151	150:5	± 1%	5.0
5**-201	200:5	± 1%	5.0
5**-251	250:5	± 1%	10.0
5**-301	300:5	± 1%	12.5
5**-401	400:5	± 1%	12.5
5**-501	500:5	± 1%	20.0
5**-601	600:5	± 1%	25.0
* 5**-751	750:5	± 1%	25.0
* 5**-801	800:5	± 1%	25.0
* 5**-102	1000:5	± 1%	25.0
* 5**-122	1200:5	± 1%	30.5

****NOTE:** When ordering, prefix Catalogue Number with model designation required, i.e. 5SFT-500, 5RL-500, etc.

Approvals



Model 5DRL

Window Diameter 1.56"

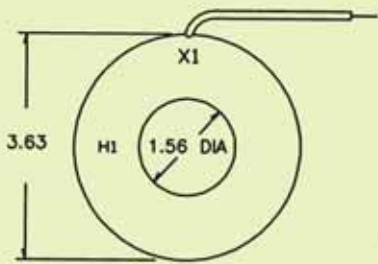
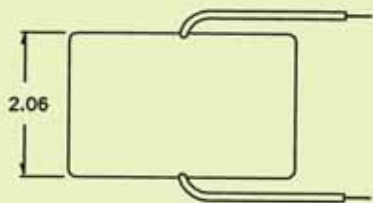
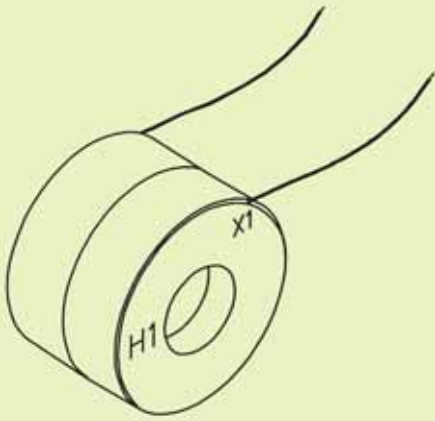

Application:

With ammeters, wattmeters, and cross current compensation.

Frequency:

50-400Hz

Insulation Level:

- 600 Volts, 10kV BIL full wave
- Flexible leads are UL 1015 105°C, CSA approved #16 AWG, 24" long
- Non-standard length to be specified
- Approximate weight: 2.0 lbs

Catalogue Number	Current Ratio	Accuracy at 60Hz	Burden VA at 60Hz
1A-500	50:5	± 2%	1.0
5DRL-500	50:5	± 2%	2.5
5DRL-600	60:5	± 1%	2.5
5DRL-750	75:5	± 1%	3.5
5DRL-101	100:5	± 1%	5.0
5DRL-151	150:5	± 1%	10.0
5DRL-201	200:5	± 1%	12.5
5DRL-251	250:5	± 1%	20.0
5DRL-301	300:5	± 1%	25.0

Catalogue Number	Current Ratio	Accuracy at 60Hz	Burden VA at 60Hz
5DRL-401	400:5	± 1%	40
5DRL-501	500:5	± 1%	50
5DRL-601	600:5	± 1%	60
5DRL-751	750:5	± 1%	60
5DRL-801	800:5	± 1%	60
5DRL-102	1000:5	± 1%	75
5DRL-122	1200:5	± 1%	90

Approvals



Model 56

Window Diameter 2.06"

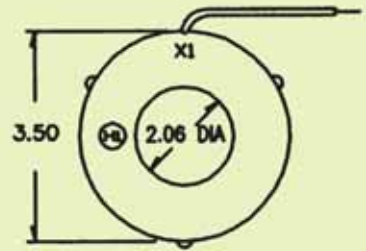
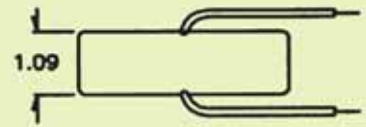
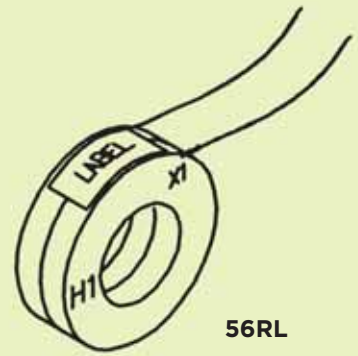
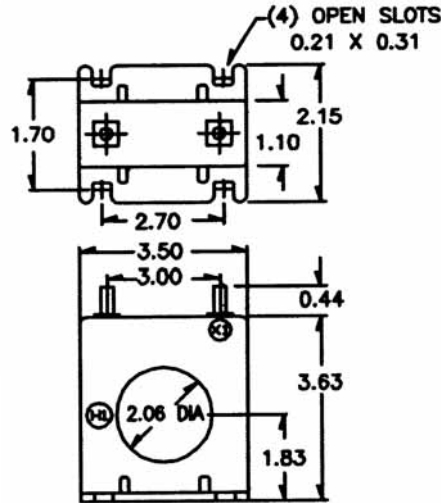
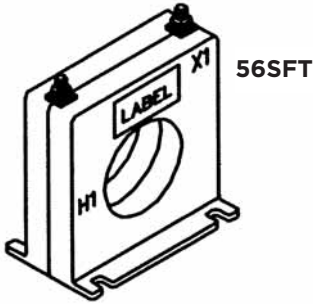

Catalogue Number	Current Ratio	Accuracy at 60Hz	Burden VA at 60Hz
56 **-500	50:5	± 3%	0.5
56 **-750	75:5	± 1%	0.5
56 **-101	100:5	± 1%	1.0
56 **-151	150:5	± 1%	2.5
56 **-201	200:5	± 1%	4.0
56 **-251	250:5	± 1%	6.0
56 **-301	300:5	± 1%	7.5
56 **-401	400:5	± 1%	10.0
56 **-501	500:5	± 1%	12.5
56 **-601	600:5	± 1%	15.0
56 **-751	750:5	± 1%	7.0
56 **-801	800:5	± 1%	8.0
56 **-102	1000:5	± 1%	10.0
56 **-122	1200:5	± 1%	12.5

****NOTE:** When ordering, prefix Catalogue Number with model designation required, i.e. 56RL - 101.

Application

With ammeters, wallmeters and cross current compensation.

Frequency

50-400Hz

Insulation Level

0.6kV, 10kV full wave

- Flexible leads are UL 1015 105°C, CSA approved #16 AWG, 24" long
- Non-standard length to be specified.
- Terminals are brass studs No. 8 - 32 UNC with one flat washer, lockwasher and regular nut
- SFT case style also available as SFL with leads
- Approximate weight: 0.6 lb

Approvals



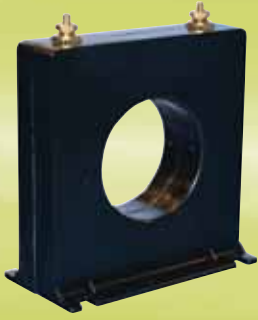

Model 6

Window Diameter 2.06"



6SFT

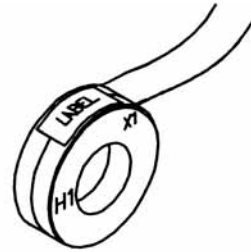

6RL

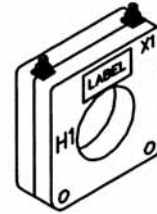

6SHT

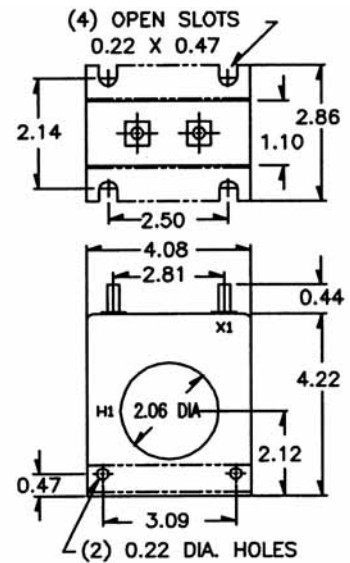
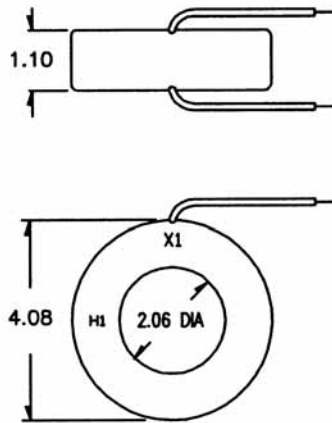
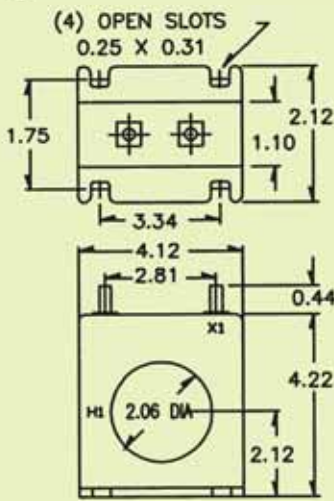

Application

With Ammeters, wattmeters, and cross current compensation.

Frequency

50-400Hz

Insulation Level

- 0.6kV, 10kV BIL full wave
- Flexible leads are UL 1015 105°C, CSA approved #16 AWG, 24" long
- Non-standard length to be specified
- Terminals are brass studs No 8-32 UNC with one flat washer, lockwasher and regular nut
- SFT and SHT case styles also available as SFL and SHL with leads
- Mounting bracket kit when required for Model 6SHT
- Approximate weight: 1.2 lbs

Approvals



Catalogue Number	Current Ratio	Accuracy at 60Hz	Burden VA at 60Hz
6 **-101	100:5	± 2%	2.0
6 **-151	150:5	± 1%	5.0
6 **-201	200:5	± 1%	5.0
6 **-251	250:5	± 1%	7.5
6 **-301	300:5	± 1%	12.5
6 **-401	400:5	± 1%	15.0
6 **-501	500:5	± 1%	25.0
6 **-601	600:5	± 1%	30.0
6 **-751	750:5	± 1%	25.0
6 **-801	800:5	± 1%	25.0
6 **-102	1000:5	± 1%	35.0
6 **-122	1200:5	± 1%	40.0
6 **-152	1500:5	± 1%	50.0

****NOTE:** When ordering, prefix Catalogue Number with model designation required, i.e. 6SHT - 201, 6RL - 301, etc.

Model 7

Window Diameter 2.50"

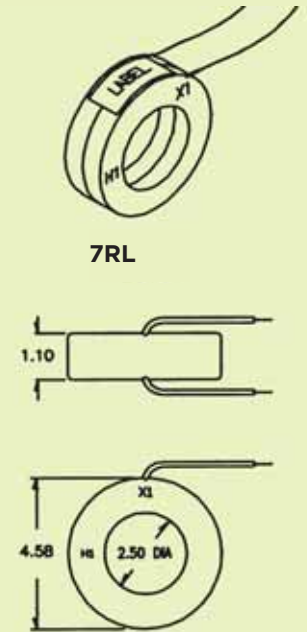
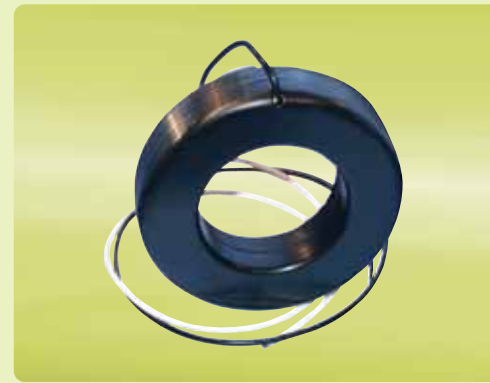
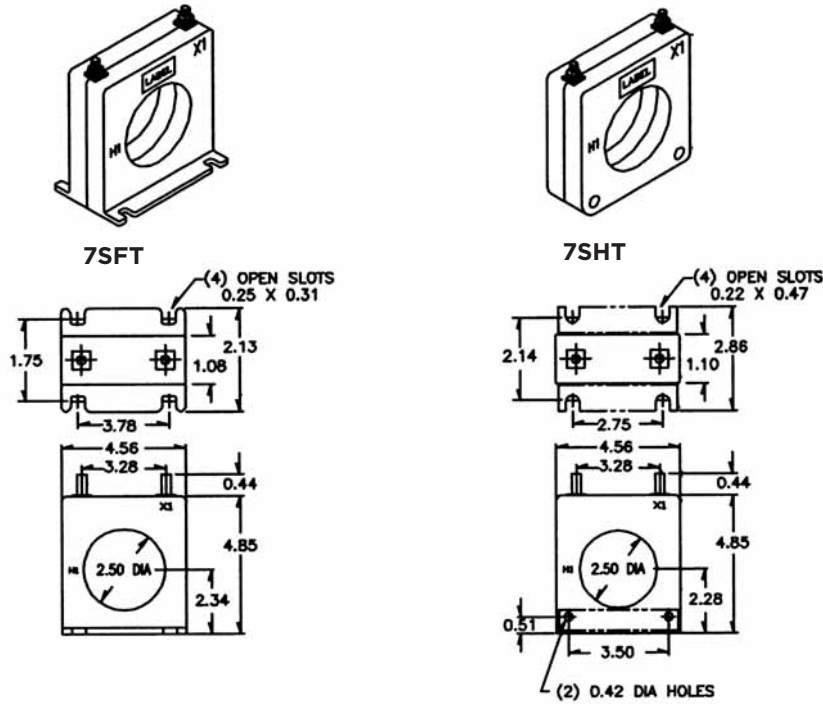

Catalogue Number	Current Ratio	Accuracy at 60Hz	Burden VA at 60Hz
7**-101	100:5	± 2%	2.0
7**-151	150:5	± 1%	5.0
7**-201	200:5	± 1%	5.0
7**-251	250:5	± 1%	5.0
7**-301	300:5	± 1%	12.5
7**-401	400:5	± 1%	15.0
7**-501	500:5	± 1%	25.0
7**-601	600:5	± 1%	30.0
7**-751	750:5	± 1%	30.0
7**-801	800:5	± 1%	35.0
7**-102	1000:5	± 1%	35.0
7**-122	1200:5	± 1%	35.0
7**-152	1500:5	± 1%	40.0
7**-162	1600:5	± 1%	45.0

****NOTE:** When ordering, prefix Catalogue Number with model designation required, i.e. 7SFT - 500, 7RL - 500, etc.

Application:

With ammeters, wattmeters and cross current compensation.

Frequency:

50-400Hz

Insulation Level:

- 600 Volts, 10kV BIL full wave
- Flexible leads are UL 1015 105°C, CSA approved #16 AWG, 24" long
- Non-standard length to be specified
- Terminals are brass studs No. 8 - 32 UNC with one flat washer, lockwasher and regular nut
- SFT and SHT case styles also available as SFL and SHL with leads
- Mounting bracket kit when required for Model 7SHT
- Approximate weight: 1.5 lbs

Approvals



Application:

With ammeters, wattmeters and cross current compensation.

Frequency:

50-400Hz

Insulation Level:

- 600 Volts, 10kV BIL full wave
- Flexible leads are UL 1015 105°C, CSA approved #16 AWG, 24" long
 - Non-standard length to be specified
 - Terminals are brass studs No. 8-32 UNC with one flat washer, lockwasher and regular nut
 - SFT case styles also available as SFL with leads
 - Approximate weight: 0.9 lb

Approvals



UL 257877

CSA 223647

Model 76

Window Diameter 3.00"



76SFT

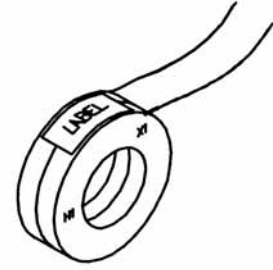

76RL

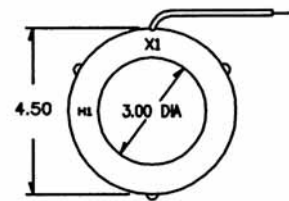
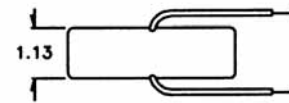
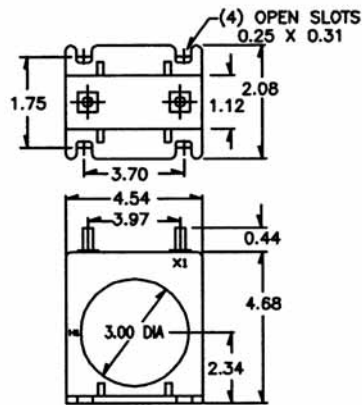













Catalogue Number	Current Ratio	Accuracy at 60Hz	Burden VA at 60Hz
76**-201	200:5	± 1%	5.0
76**-251	250:5	± 1%	5.0
76**-301	300:5	± 1%	6.0
76**-401	400:5	± 1%	10.0
76**-501	500:5	± 1%	10.0
76**-601	600:5	± 1%	10.0
76**-751	750:5	± 1%	10.0
76**-801	800:5	± 1%	12.5
76**-102	1000:5	± 1%	12.5
76**-122	1200:5	± 1%	12.5
76**-152	1500:5	± 1%	12.5
76**-162	1600:5	± 1%	12.5
76**-202	2000:5	± 1%	15.0

Current Transformers

600V Class Window Type for Metering and Relaying



















600V Three Phase
Current Transformers
ANSI Rated
Window Type

Contents				Page	Contents				Page
Window Sizes	Models	Body Sizes			Window Sizes	Models	Body Sizes		
1.56 	10	W4.08 H 5.03 D 2.10	17	4.00 	115MR	W 7.00 H 7.56 D 4.00	30-31		
3.25 	8RL 8SHT	W5.73 H 6.17 D 1.15	18	4.62 	117MR	W 7.00 H 7.56 D 4.00	32-33		
4.25 	19RL 19RT 19SHT	W 5.92 H 6.17 D 1.15	19	5.75 	120	W 8.50 H 8.50 D 2.17	34		
1.25 1.63 2.00 2.50 3.13 	21 22 23 24 25	W 4.63 H 5.54 D 3.00	20-22	6.31 	125	W 8.50 H 8.94 D 1.28	35		
1.56 2.00 2.50 	64 65 66	W 4.00 H 4.44 D 1.75	23-24	8.25 	128	W 10.48 H 10.92 D 1.53	36		
4.00 	100	W 7.00 H 7.00 D 2.17	25	5.75 	130	W 8.50 H 8.94 D .290	37		
4.00 	110	W 7.00 H 7.00 D 2.88	26	5.75 	135	W 9.21 H 9.65 D 3.00	38		
2.25 2.75 3.25 4.00 4.62 	112 113 114 115 117	W 7.00 H 7.12 D 4.00	27-29	5.75 	135MR	W 9.21 H 9.65 D 3.00	39-41		

Current Transformers

600V Class Window Type for Metering and Relaying

600V Three Phase
Current Transformers
ANSI Rated
Window Type

Contents				Page	Contents				Page
Window Sizes	Models	Body Sizes			Window Sizes	Models	Body Sizes		
5.50	 137	W 9.88 H 10.32 D 5.00	42	7.25	 142MR	W 11.10 H 11.91 D 3.00	57-59		
5.50	 137MR	W 9.88 H 10.32 D 5.00	43-45	7.31	 143	W 11.10 H 11.91 D 3.00	60		
6.50	 139	W 9.88 H 10.32 D 5.00	46	7.31	 143MR	W 11.10 H 11.91 D 3.00	61-63		
6.50	 139MR	W 9.88 H 10.32 D 5.00	47	6.00	 144	W 11.10 H 11.91 D 3.00	64		
8.13	 140	W 11.10 H 11.91 D 3.00	48	6.00	 144MR	W 11.10 H 11.91 D 3.00	65-67		
8.13	 140MR	W 11.10 H 11.91 D 3.00	49-51	6.00	 145 145MR (Page 69)	W 11.10 H 11.91 D 6.00	68-71		
8.13	 141	W 11.10 H 11.91 D 3.00	52	4.25	 170RL 170SHT	W 6.73 H 7.17 D 1.28	72		
8.13	 141MR	W 11.10 H 11.91 D 3.00	53-55	1.25 1.75 2.13 2.50 3.06	 191 192 193 194 195	W 4.50 H 5.32 D 2.19	73-75		
7.25	 142	W 11.10 H 11.91 D 3.00	56	1.50 2.25 3.00 3.38 3.75	 296 297 298 299 300	W 5.96 H 6.75 D 3.00	76-78		

Model 10

Window Diameter 1.56"

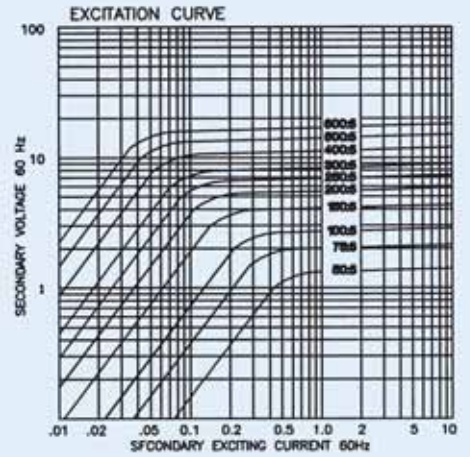
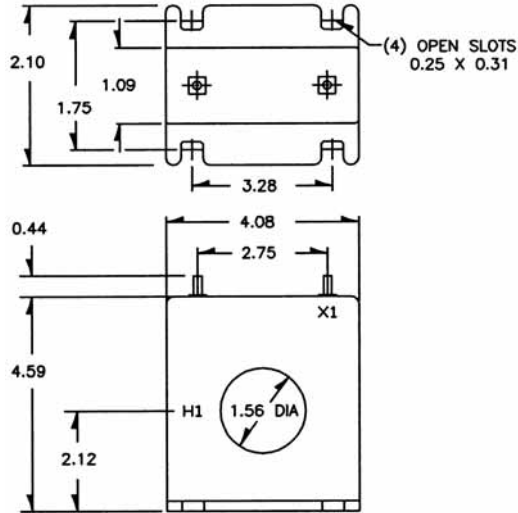
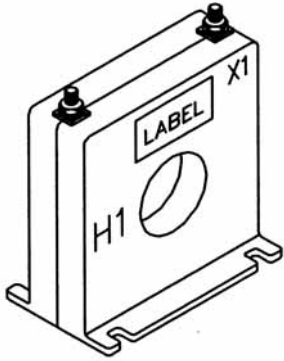

Application:
Metering

Frequency:
50 - 400Hz

Insulation Level:
600 Volts, 10kV BIL full wave
 • Terminals are brass studs No. 8 - 32 with one flatwasher, lockwasher and regular nut
 • Approximate weight: 2.5 lbs

Approvals



Catalogue Number	Current Ratio	V.A. for ±1% class	ANSI Metering class at 60Hz					Secondary winding resistance (OHMS @ 75 °C)	Continuous thermal rating factor	
			B0.1	B0.2	B0.5	B0.9	B1.8		@30 °C	@55 °C
10SFT-500	50:5	2.0±2%	4.8	-	-	-	-	0.007	2.0	2.0
10SFT-750	75:5	2.5	1.2	4.8	-	-	-	0.010	2.0	2.0
10SFT-101	100:5	3.0	1.2	2.4	4.8	-	-	0.018	2.0	2.0
10SFT-151	150:5	5.0	0.6	0.6	2.4	4.8	-	0.031	2.0	2.0
10SFT-201	200:5	7.5	0.3	0.6	1.2	2.4	4.8	0.043	2.0	1.5
10SFT-251	250:5	10.0	0.3	0.3	1.2	1.2	2.4	0.053	2.0	1.5
10SFT-301	300:5	15.0	0.3	0.3	0.6	1.2	2.4	0.070	2.0	1.5
10SFT-401	400:5	20.0	0.3	0.3	0.3	0.6	1.2	0.114	1.5	1.0
10SFT-501	500:5	30.0	0.3	0.3	0.3	0.6	1.2	0.128	1.33	1.0
10SFT-601	600:5	40.0	0.3	0.3	0.3	0.6	0.6	0.192	1.33	0.8

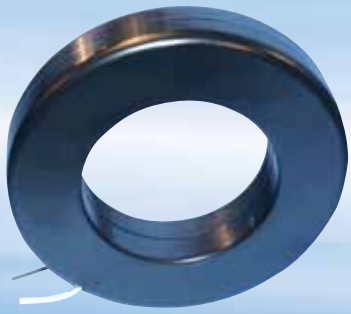

Model 8

Window Diameter 3.25"

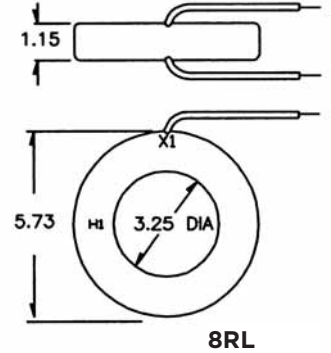
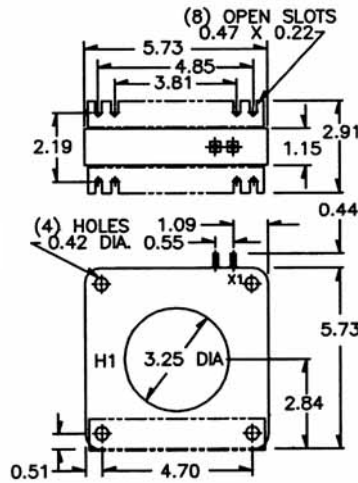
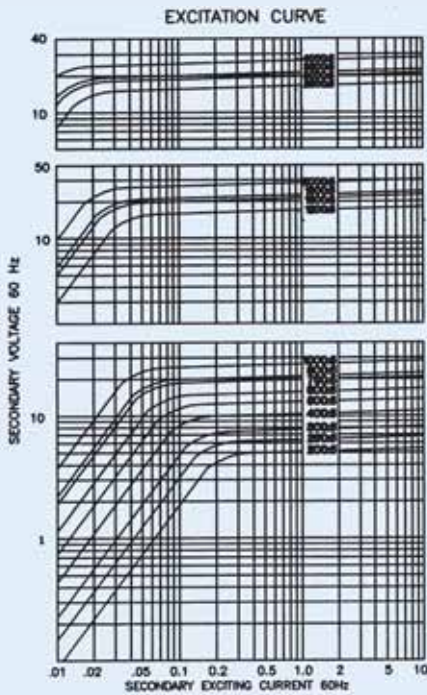

Application:
Metering

Frequency:
50-400Hz

Insulation Level:

- 600 Volts, 10kV BIL full wave
- Terminals are brass studs No 8-32 with one flat washer, lockwasher and regular nut
- Flexible leads are UL 1015 105°C, CSA approved, #16 AWG, 24" long
- Non-standard length to be specified
- Model 8SHT also available as 8SHL, with leads
- Order mounting bracket kit separately when required for Model 8SHT
- Approximate weight: 2.5 lbs

Catalogue Number	Current Ratio	V.A. for ±1% class	ANSI Metering class at 60Hz					Secondary winding resistance (OHMS @ 75 °C)	Continuous thermal rating factor	
			B0.1	B0.2	B0.5	B0.9	B1.8		@30 °C	@55 °C
8**-201	200:5	5.0	1.2	1.2	2.4	4.8	4.8	0.030	2.0	2.0
8**-251	250:5*	7.5	0.6	0.6	1.2	2.4	4.8	0.044	2.0	2.0
8**-301	300:5*	15.0	0.6	0.6	1.2	2.4	2.4	0.049	2.0	2.0
8**-401	400:5*	25.0	0.3	0.3	0.6	1.2	2.4	0.079	2.0	1.5
8**-501	500:5*	35.0	0.3	0.3	0.6	0.6	1.2	0.102	2.0	1.5
8**-601	600:5*	50.0	0.3	0.3	0.6	0.6	1.2	0.147	1.5	1.33
8**-751	750:5*	50.0	0.3	0.3	0.3	0.6	1.2	0.184	1.5	1.0
8**-801	800:5*	60.0	0.3	0.3	0.3	0.6	0.6	0.197	1.5	1.0
8**-102	1000:5*	75.0	0.3	0.3	0.3	0.3	0.6	0.246	1.33	1.0
8**-122	1200:5*	75.0	0.3	0.3	0.3	0.3	0.3	0.169	1.5	1.0
8**-152	1500:5*	90.0	0.3	0.3	0.3	0.3	0.3	0.316	1.33	1.0
8**-162	1600:5*	100.0	0.3	0.3	0.3	0.3	0.3	0.337	1.33	0.8
8**-202	2000:5*	120.0	0.3	0.3	0.3	0.3	0.3	0.422	1.0	0.8
8**-252	2500:5*	50.0	0.3	0.3	0.3	0.3	0.3	0.438	1.0	0.8
8**-302	3000:5	60.0	0.3	0.3	0.3	0.3	0.3	0.526	1.0	0.8
8**-322	3200:5	70.0	0.3	0.3	0.3	0.3	0.3	0.561	1.0	0.8
8**-402	4000:5	80.0	0.3	0.3	0.3	0.3	0.3	0.973	0.8	0.6

****NOTE:** When ordering, prefix catalogue number with model designation required, i.e. 8SHT-201, 8RL-301, etc.

Approvals



Model 19

Window Diameter 4.25"



19SHT

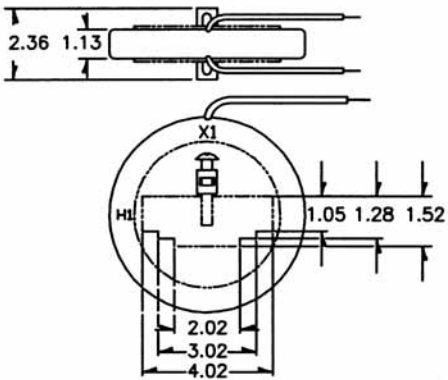
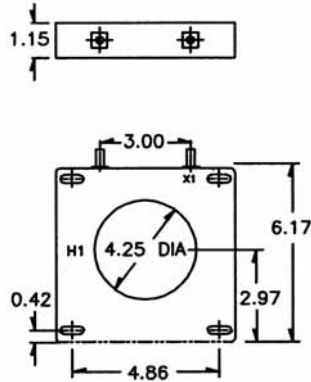

19RL (BUS BAR MOUNTING KIT SHOWN)

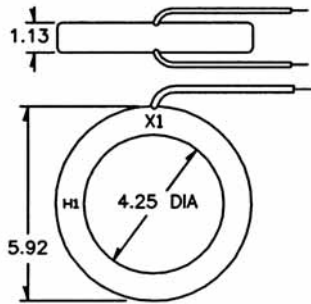

19RL

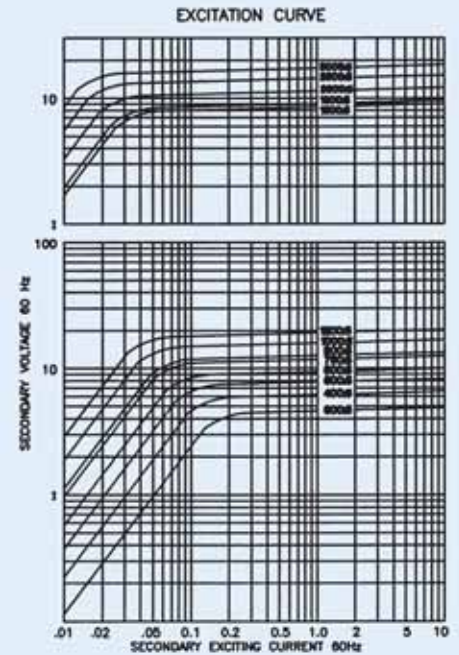

Application:

With ammeters, wattmeters and cross current compensation.

Frequency:

50-400Hz

Insulation Level:

- 600 Volts, 10kV BIL full wave
- Flexible leads are UL 1015 105°C, CSA approved #16 AWG, 24" long
- Non-standard length to be specified
- Terminals are brass studs No. 8 - 32 UNC with one flat washer, lockwasher and regular nut
- SFT and SHT case styles also available as SFL and SHL with leads
- Mounting bracket kit when required for Model 7SHT
- Approximate weight: 1.5 lbs

Approvals



Catalogue Number	Current Ratio	V.A. for ±1% class	ANSI Metering class at 60Hz					Secondary winding resistance (OHMS @ 75°C)	Continuous thermal rating factor	
			B0.1	B0.2	B0.5	B0.9	B1.8		@30°C	@55°C
19**-301	300:5	4.0	0.6	0.6	2.4	2.4	4.8	0.048	2.0	2.0
19**-401	400:5	10.0	0.3	0.3	1.2	2.4	2.4	0.064	2.0	2.0
19**-501	500:5	15.0	0.3	0.3	0.6	1.2	2.4	0.087	2.0	1.5
19**-601	600:5	15.0	0.3	0.3	0.6	1.2	1.2	0.116	2.0	1.5
19**-751	750:5	25.0	0.3	0.3	0.3	0.6	1.2	0.145	1.5	1.33
19**-801	800:5	30.0	0.3	0.3	0.3	0.6	1.2	0.155	1.5	1.33
19**-102	1000:5	30.0	0.3	0.3	0.3	0.6	1.2	0.242	1.33	1.0
19**-122	1200:5	40.0	0.3	0.3	0.3	0.3	0.6	0.291	1.33	1.0
19**-152	1500:5	15.0	0.3	0.3	0.6	0.6	0.6	0.200	1.5	1.0
19**-162	1600:5	15.0	0.3	0.3	0.3	0.6	0.6	0.213	1.5	1.0
19**-202	2000:5	20.0	0.3	0.3	0.3	0.3	0.6	0.266	1.33	1.0
19**-252	2500:5	20.0	0.3	0.3	0.3	0.3	0.3	0.333	1.0	0.8
19**-302	3000:5	25.0	0.3	0.3	0.3	0.3	0.3	0.399	1.0	0.8

****NOTE:** When ordering, prefix catalogue number with model designation required, i.e. 19RL - 301, or 19SHT - 301, etc.

Model 22

Window Diameter 1.63"
Approximate weight: 9 lbs

Catalogue Number	Current Ratio	V.A. for ±1% class	ANSI Metering class at 60Hz					Secondary winding resistance (OHMS @ 75°C)	Continuous thermal rating factor	
			B0.1	B0.2	B0.5	B0.9	B1.8		@30°C	@55°C
22 - 101	100:5	C10	0.6	1.2	2.4	2.4	4.8	0.060	2.0	2.0
22 - 151	150:5	C10	0.3	0.6	1.2	1.2	2.4	0.090	2.0	2.0
22 - 201	200:5	C20	0.3	0.3	0.6	1.2	1.2	0.120	2.0	1.5
22 - 251	250:5	C20	0.3	0.3	0.6	0.6	1.2	0.150	1.5	1.5
22 - 301	300:5	C20	0.3	0.3	0.3	0.6	0.6	0.180	1.5	1.33
22 - 401	400:5	C20	0.3	0.3	0.3	0.3	0.6	0.241	1.5	1.0
22 - 501	500:5	C50	0.3	0.3	0.3	0.3	0.3	0.301	1.5	1.0

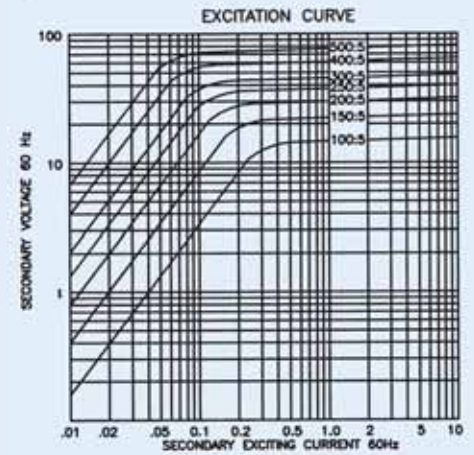

Model 23

Window Diameter 2.00"
Approximate weight: 8.5 lbs

Catalogue Number	Current Ratio	V.A. for ±1% class	ANSI Metering class at 60Hz					Secondary winding resistance (OHMS @ 75°C)	Continuous thermal rating factor	
			B0.1	B0.2	B0.5	B0.9	B1.8		@30°C	@55°C
23 - 101	100:5	-	0.6	0.6	2.4	4.8	-	0.051	2.0	2.0
23 - 151	150:5	C10	0.6	0.6	0.6	1.2	2.4	0.076	2.0	2.0
23 - 201	200:5	C10	0.3	0.6	0.6	1.2	2.4	0.114	2.0	1.5
23 - 251	250:5	C20	0.3	0.3	0.6	0.6	1.2	0.143	2.0	1.5
23 - 301	300:5	C20	0.3	0.3	0.3	0.6	1.2	0.171	1.5	1.33
23 - 401	400:5	C20	0.3	0.3	0.3	0.3	0.6	0.228	1.5	1.0
23 - 501	500:5	C20	0.3	0.3	0.3	0.3	0.3	0.286	1.5	1.0
23 - 601	600:5	C50	0.3	0.3	0.3	0.3	0.3	0.343	1.33	1.0

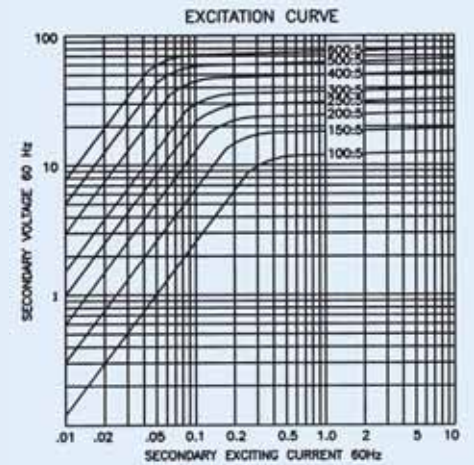

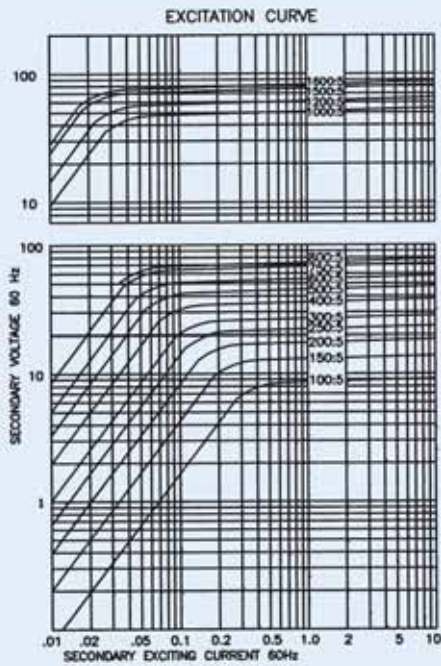

Model 24

Window Diameter 2.5"
Approximate weight: 6.5 lbs

Catalogue Number	Current Ratio	V.A. for $\pm 1\%$ class	ANSI Metering class at 60Hz					Secondary winding resistance (OHMS @ 75 °C)	Continuous thermal rating factor	
			B0.1	B0.2	B0.5	B0.9	B1.8		@30 °C	@55 °C
24 - 101	100:5	-	0.6	1.2	2.4	4.8	-	0.046	2.0	2.0
24 - 151	150:5	-	0.6	0.6	1.2	2.4	4.8	0.069	2.0	2.0
24 - 201	200:5	C10	0.3	0.3	0.6	1.2	2.4	0.096	2.0	1.5
24 - 251	250:5	C10	0.3	0.3	0.3	0.6	1.2	0.118	2.0	1.5
24 - 301	300:5	C10	0.3	0.3	0.3	0.6	1.2	0.133	2.0	1.5
24 - 401	400:5	C20	0.3	0.3	0.3	0.6	0.6	0.212	1.5	1.0
24 - 501	500:5	C20	0.3	0.3	0.3	0.3	0.6	0.265	1.5	1.0
24 - 601	600:5	C20	0.3	0.3	0.3	0.3	0.3	0.317	1.33	1.0
24 - 751	750:5	C20	0.3	0.3	0.3	0.3	0.3	0.396	1.0	1.0
24 - 801	800:5	C20	0.3	0.3	0.3	0.3	0.3	0.423	1.0	0.8
24 - 102	1000:5	C10	0.3	0.3	0.3	0.3	0.3	0.446	1.0	0.8
24 - 122	1200:5	C10	0.3	0.3	0.3	0.3	0.3	0.535	1.0	0.8
24 - 152	1500:5	C10	0.3	0.3	0.3	0.3	0.3	0.669	1.0	0.6
24 - 162	1600:5	C10	0.3	0.3	0.3	0.3	0.3	0.713	0.8	0.6

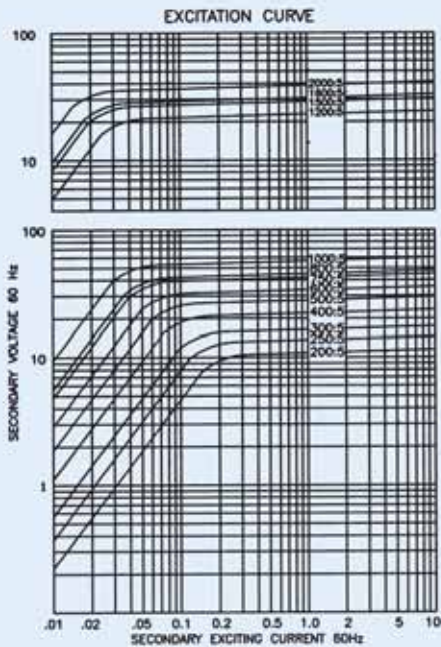

Model 25

Window Diameter 3.13"
Approximate weight: 5.5 lbs

Catalogue Number	Current Ratio	V.A. for $\pm 1\%$ class	ANSI Metering class at 60Hz					Secondary winding resistance (OHMS @ 75 °C)	Continuous thermal rating factor	
			B0.1	B0.2	B0.5	B0.9	B1.8		@30 °C	@55 °C
24 - 101	100:5	-	0.6	1.2	2.4	4.8	-	0.046	2.0	2.0
25 - 201	200:5	10	0.6	0.6	1.2	2.4	4.8	0.081	2.0	2.0
25 - 251	250:5	15	0.3	0.3	1.2	1.2	2.4	0.108	2.0	1.5
25 - 301	300:5	20	0.3	0.3	0.6	1.2	2.4	0.129	2.0	1.5
25 - 401	400:5	30	0.3	0.3	0.6	0.6	1.2	0.194	1.5	1.33
25 - 501	500:5	45	0.3	0.3	0.3	0.6	1.2	0.243	1.5	1.0
25 - 601	600:5	60	0.3	0.3	0.3	0.3	0.6	0.292	1.33	1.0
25 - 751	750:5	75	0.3	0.3	0.3	0.3	0.6	0.364	1.0	0.8
25 - 801	800:5	80	0.3	0.3	0.3	0.3	0.3	0.389	1.0	0.8
25 - 102	1000:5	100	0.3	0.3	0.3	0.3	0.3	0.486	1.0	0.8
25 - 122	1200:5	75	0.3	0.3	0.3	0.3	0.3	0.389	1.0	0.8
25 - 152	1500:5	90	0.3	0.3	0.3	0.3	0.3	0.617	1.0	0.8
25 - 162	1600:5	95	0.3	0.3	0.3	0.3	0.3	0.658	1.0	0.6
25 - 202	2000:5	100	0.4	0.3	0.3	0.3	0.3	0.822	0.8	0.6

Models 64, 65, 66

Window Diameter 1.56", 2.0", 2.5"

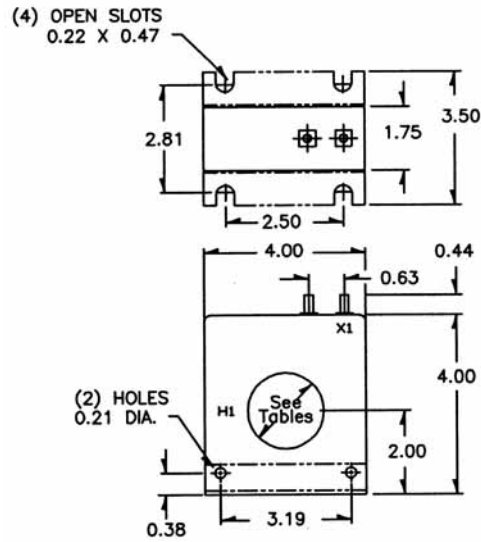
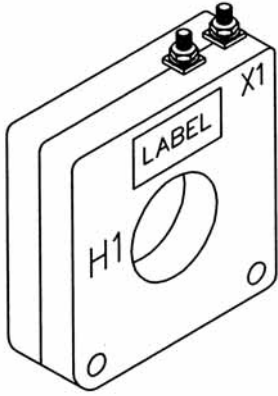

Application:
Metering

Frequency:
50 - 400Hz

Insulation Level:

- 600 Volts, 10kV BIL full wave
- Terminals are brass studs No. 8 - 32 with one flatwasher, lockwasher and regular nut
- Order mounting bracket kit separately

Approvals



Model 64

Window Diameter 1.56"
Approximate weight: 3.75 lbs

Catalogue Number	Current Ratio	V.A. for $\pm 1\%$ class	ANSI Metering class at 60Hz					Secondary winding resistance (OHMS @ 75°C)	Continuous thermal rating factor	
			B0.1	B0.2	B0.5	B0.9	B1.8		@30°C	@55°C
64 - 500	50:5	2.5 \pm 2%	2.4	-	-	-	-	0.011	2.0	2.0
64 - 750	75:5	4.0	1.2	2.4	-	-	-	0.020	2.0	2.0
64 - 101	100:5	5.0	1.2	1.2	4.8	4.8	-	0.026	2.0	2.0
64 - 151	150:5	7.5	0.6	0.6	1.2	2.4	4.8	0.043	2.0	2.0
64 - 201	200:5	12.5	0.3	0.3	1.2	1.2	2.4	0.063	2.0	1.5
64 - 251	250:5	20.0	0.3	0.3	0.6	1.2	2.4	0.074	2.0	1.5
64 - 301	300:5	35.0	0.3	0.3	0.3	0.6	1.2	0.086	2.0	1.5
64 - 401	400:5	50.0	0.3	0.3	0.3	0.6	1.2	0.110	1.5	1.33
64 - 501	500:5	50.0	0.3	0.3	0.3	0.3	0.6	0.173	1.5	1.0

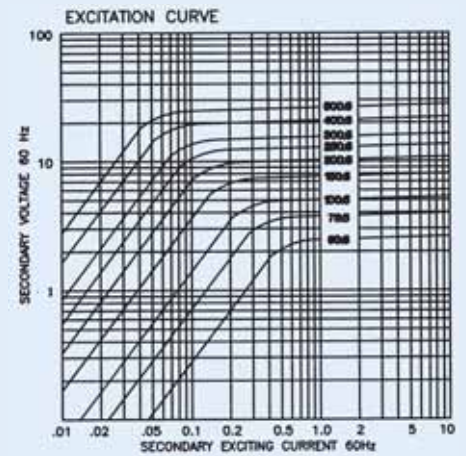

Model 100

Window Diameter 1.56", 2.0", 2.5"

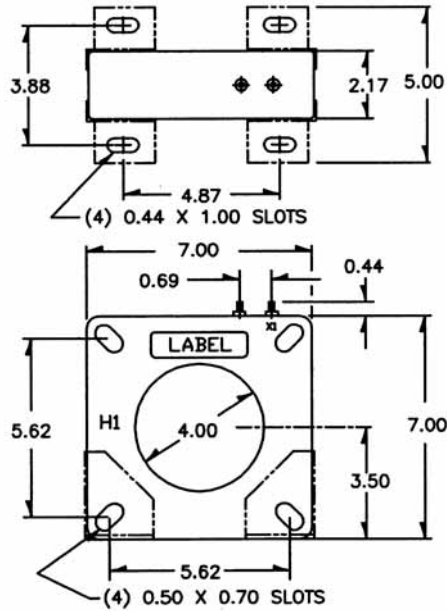
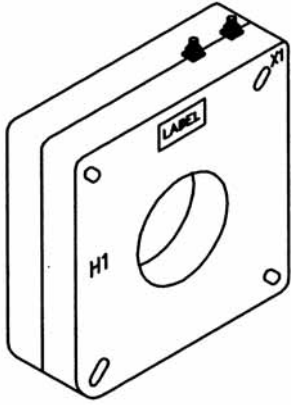

Catalogue Number	Current Ratio	V.A. for ±1% class	ANSI Metering class at 60Hz					Secondary winding resistance (OHMS @ 75° C)	Continuous thermal rating factor	
			B0.1	B0.2	B0.5	B0.9	B1.8		@30° C	@55° C
100 - 201	200:5	C10	0.6	0.6	1.2	2.4	-	0.057	2.0	2.0
100 - 301	300:5*	C10	0.3	0.3	0.6	1.2	-	0.091	2.0	2.0
100 - 401	400:5*	C20	0.3	0.3	0.6	0.6	1.2	0.133	2.0	2.0
100 - 501	500:5*	C20	0.3	0.3	0.3	0.6	1.2	0.166	2.0	1.5
100 - 601	600:5*	C20	0.3	0.3	0.3	0.3	0.6	0.199	2.0	1.5
100 - 801	800:5*	C20	0.3	0.3	0.3	0.3	0.3	0.266	1.5	1.33
100 - 102	1000:5*	C50	0.3	0.3	0.3	0.3	0.3	0.332	1.5	1.0
100 - 122	1200:5*	C20	0.3	0.3	0.3	0.3	0.3	0.374	1.5	1.0
100 - 152	1500:5*	C20	0.3	0.3	0.3	0.3	0.3	0.468	1.33	1.0
100 - 162	1600:5*	C50	0.3	0.3	0.3	0.3	0.3	0.499	1.33	1.0
100 - 202	2000:5*	C50	0.3	0.3	0.3	0.3	0.3	0.624	1.0	0.8
100 - 252	2500:5*	C50	0.3	0.3	0.3	0.3	0.3	0.735	1.0	0.8
100 - 302	3000:5*	C50	0.3	0.3	0.3	0.3	0.3	0.882	1.0	0.8

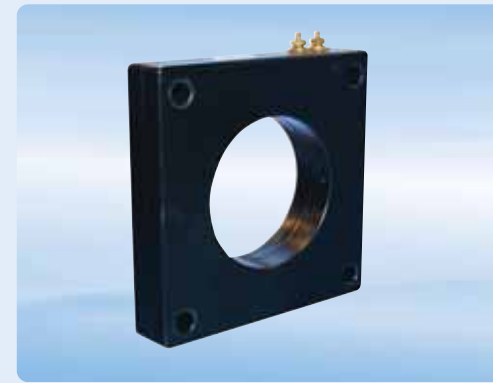

Application:
Relaying and metering

Frequency:
50 - 400Hz

Insulation Level:
600 Volts, 10kV BIL full wave

- Terminals are brass studs No. 8 - 32 with one flatwasher, lockwasher and regular nut
- Order mounting bracket kit separately
- Multi-ratios available upon request
- Approximate weight: 9.5 lbs

Approvals

UL [®] **US** UL 257877
CSA 223647

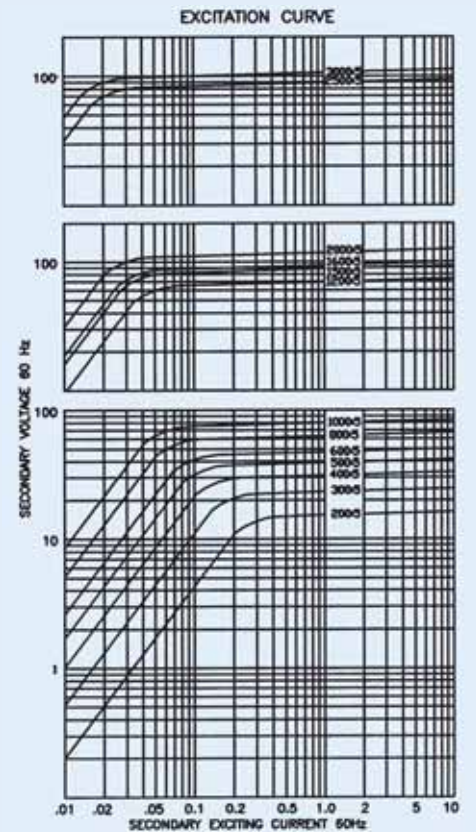

Application:

Relaying and metering

Frequency:

50 - 400Hz:

Insulation Level:

600 Volts, 10kV BIL full wave

- Terminals are brass studs No. 8 - 32 with one flat washer, lockwasher and regular nut
- Other ratios available upon request
- Order mounting bracket kit separately
- Approximate weight: 13 lbs

Approvals



Model 110

Window Diameter 4.0"

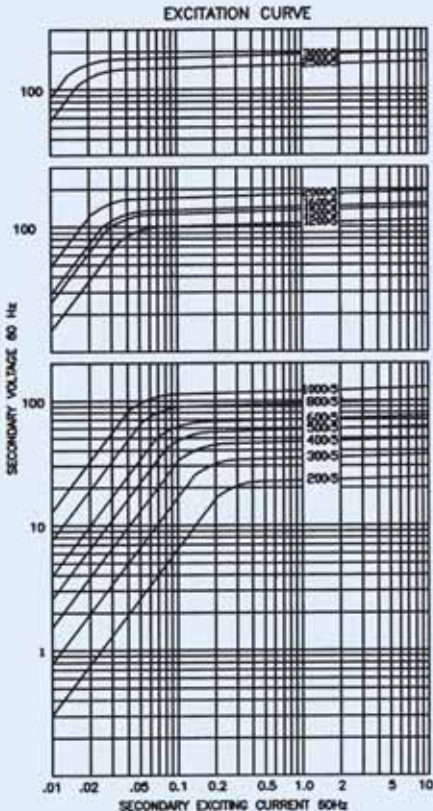
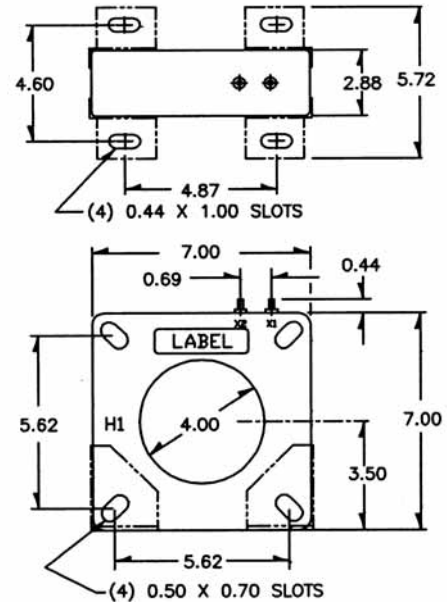
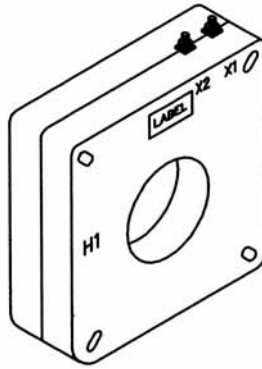

Catalogue Number	Current Ratio	V.A. for ±1% class	ANSI Metering class at 60Hz					Secondary winding resistance (OHMS @ 75°C)	Continuous thermal rating factor	
			B0.1	B0.2	B0.5	B0.9	B1.8		@30°C	@55°C
100 - 201	200:5	C10	0.6	0.6	1.2	2.4	-	0.057	2.0	2.0
110 - 201	200:5	C10	0.6	1.2	1.2	2.4	-	0.085	2.0	2.0
110 - 301	300:5	C20	0.3	0.6	0.6	1.2	2.4	0.128	2.0	2.0
110 - 401	400:5	C20	0.3	0.3	0.3	0.6	1.2	0.152	2.0	2.0
110 - 501	500:5	C20	0.3	0.3	0.3	0.6	0.6	0.214	2.0	1.5
110 - 601	600:5	C50	0.3	0.3	0.3	0.3	0.6	0.256	2.0	1.5
110 - 801	800:5	C50	0.3	0.3	0.3	0.3	0.3	0.342	1.5	1.33
110 - 102	1000:5	C50	0.3	0.3	0.3	0.3	0.3	0.427	1.5	1.0
110 - 122	1200:5	C50	0.3	0.3	0.3	0.3	0.3	0.489	1.5	1.0
110 - 152	1500:5	C100	0.3	0.3	0.3	0.3	0.3	0.611	1.33	1.0
110 - 162	1600:5	C100	0.3	0.3	0.3	0.3	0.3	0.652	1.0	1.0
110 - 202	2000:5	C100	0.3	0.3	0.3	0.3	0.3	0.815	1.0	0.8
110 - 252	2500:5	C100	0.3	0.3	0.3	0.3	0.3	0.974	1.0	0.8
110 - 302	3000:5	C100	0.3	0.3	0.3	0.3	0.3	1.168	1.0	0.6

Models 112, 113, 114, 115, 117

Window Diameter 2.25", 2.75", 3.25", 4.0", 4.62"

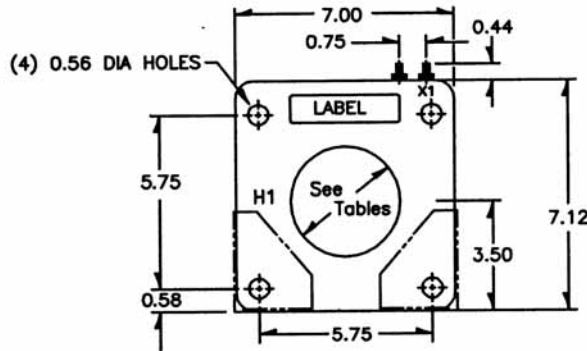
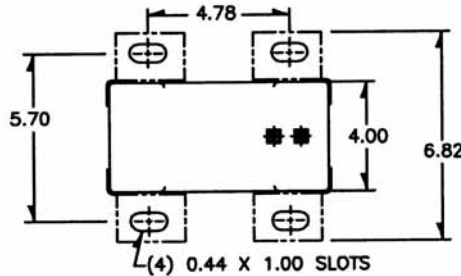
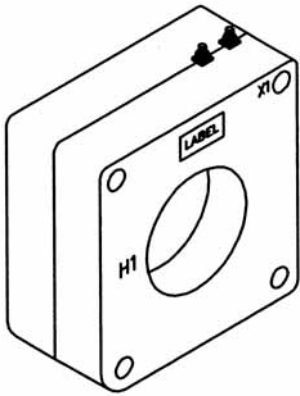

Model 112

Window Diameter 2.25"

Approximate weight: 25 lbs

Catalogue Number	Current Ratio	V.A. for ±1% class	ANSI Metering class at 60Hz					Secondary winding resistance (OHMS @ 75 °C)	Continuous thermal rating factor	
			B0.1	B0.2	B0.5	B0.9	B1.8		@30 °C	@55 °C
112 - 500	50:5	C10	1.2	2.4	-	-	-	0.029	2.0	2.0
112 - 750	75:5	C10	0.6	1.2	2.4	4.8	-	0.046	2.0	2.0
112 - 101	100:5*	C20	0.6	0.6	2.4	2.4	4.8	0.062	2.0	2.0
112 - 151	150:5*	C20	0.3	0.6	1.2	1.2	2.4	0.093	2.0	2.0
112 - 201	200:5*	C50	0.3	0.3	0.3	0.6	1.2	0.124	2.0	2.0
112 - 251	250:5*	C50	0.3	0.3	0.3	0.3	0.6	0.155	2.0	2.0
112 - 301	300:5*	C50	0.3	0.3	0.3	0.3	0.6	0.186	2.0	2.0
112 - 401	400:5*	C100	0.3	0.3	0.3	0.3	0.3	0.248	2.0	1.5
112 - 501	500:5*	C100	0.3	0.3	0.3	0.3	0.3	0.341	2.0	1.5
112 - 601	600:5*	C100	0.3	0.3	0.3	0.3	0.3	0.409	1.5	1.33
112 - 751	750:5*	C200	0.3	0.3	0.3	0.3	0.3	0.495	1.5	1.0
112 - 801	800:5*	C200	0.3	0.3	0.3	0.3	0.3	0.529	1.5	1.0
112 - 102	1000:5*	C200	0.3	0.3	0.3	0.3	0.3	0.661	1.33	1.0
112 - 122	1200:5*	C200	0.3	0.3	0.3	0.3	0.3	0.793	1.33	1.0

Application:
Metering

Frequency:
50 - 400Hz

Insulation Level:
600 Volts, 10kV BIL full wave
• Terminals are brass studs No. 8 - 32 with one flatwasher, lockwasher and regular nut
• Order mounting bracket kit separately

Approvals

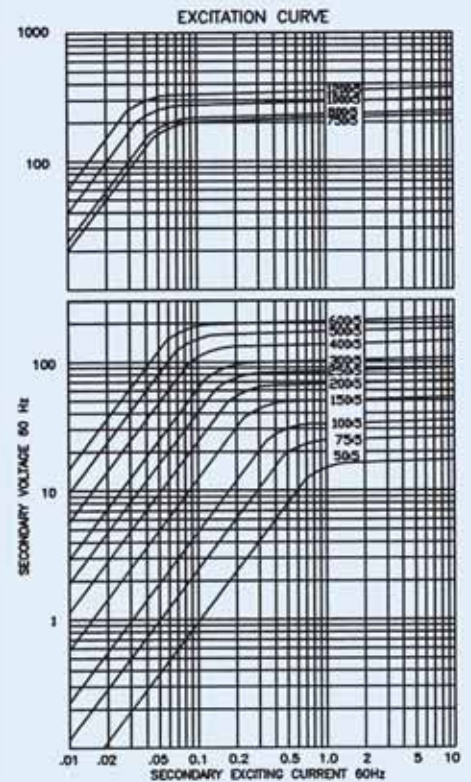

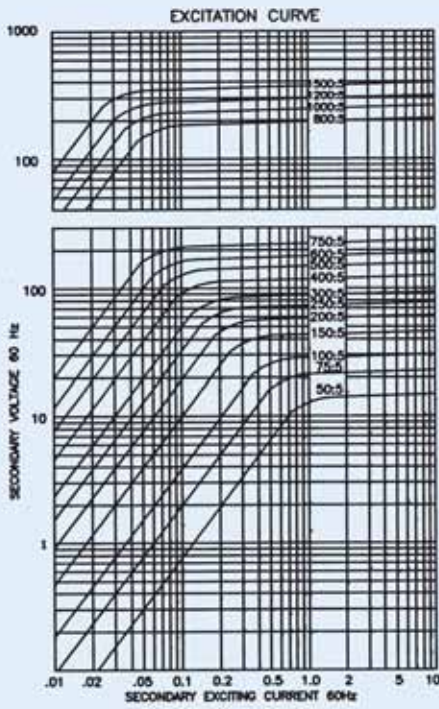

Model 113

Window Diameter 2.75"

Approximate weight: 23 lbs

Catalogue Number	Current Ratio	V.A. for $\pm 1\%$ class	ANSI Metering class at 60Hz					Secondary winding resistance (OHMS @ 75°C)	Continuous thermal rating factor	
			B0.1	B0.2	B0.5	B0.9	B1.8		@30°C	@55°C
113 - 500	50:5	C10	2.4	4.8	-	-	-	0.033	2.0	2.0
113 - 750	75:5	C10	0.6	1.2	4.8	4.8	-	0.043	2.0	2.0
113 - 101	100:5	C20	0.6	0.6	2.4	2.4	4.8	0.059	2.0	2.0
113 - 151	150:5	C20	0.3	0.3	0.6	1.2	2.4	0.089	2.0	2.0
113 - 201	200:5*	C20	0.3	0.3	0.6	0.6	1.2	0.118	2.0	2.0
113 - 251	250:5*	C50	0.3	0.3	0.6	0.6	1.2	0.163	2.0	2.0
113 - 301	300:5*	C50	0.3	0.3	0.3	0.6	1.2	0.195	2.0	2.0
113 - 401	400:5*	C100	0.3	0.3	0.3	0.3	0.6	0.260	2.0	1.5
113 - 501	500:5*	C100	0.3	0.3	0.3	0.3	0.3	0.325	2.0	1.5
113 - 601	600:5*	C100	0.3	0.3	0.3	0.3	0.3	0.390	1.5	1.33
113 - 751	750:5*	C200	0.3	0.3	0.3	0.3	0.3	0.488	1.5	1.0
113 - 801	800:5*	C200	0.3	0.3	0.3	0.3	0.3	0.503	1.5	1.0
113 - 102	1000:5*	C200	0.3	0.3	0.3	0.3	0.3	0.629	1.33	1.0
113 - 122	1200:5*	C200	0.3	0.3	0.3	0.3	0.3	0.755	1.33	1.0
113 - 152	1500:5*	C200	0.3	0.3	0.3	0.3	0.3	0.943	1.0	0.8

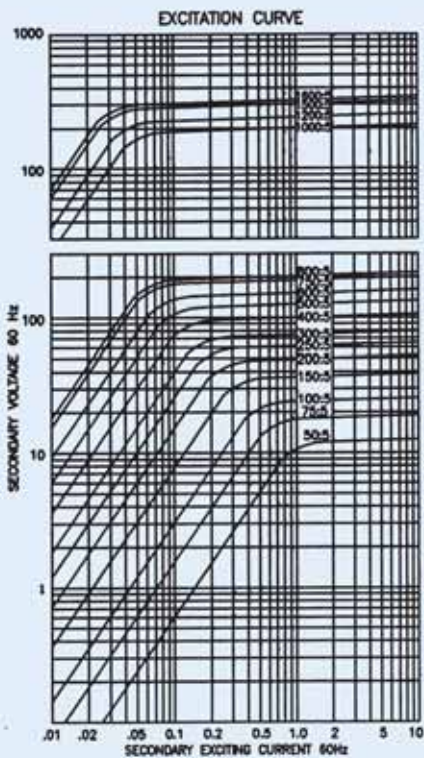

Model 114

Window Diameter 3.25"

Approximate weight: 22 lbs

Catalogue Number	Current Ratio	V.A. for $\pm 1\%$ class	ANSI Metering class at 60Hz					Secondary winding resistance (OHMS @ 75°C)	Continuous thermal rating factor	
			B0.1	B0.2	B0.5	B0.9	B1.8		@30°C	@55°C
114 - 500	50:5	-	1.2	4.8	-	-	-	0.024	2.0	2.0
114 - 750	75:5	C10	1.2	2.4	4.8	-	-	0.040	2.0	2.0
114 - 101	100:5	C10	1.2	1.2	2.4	4.8	-	0.055	2.0	2.0
114 - 151	150:5*	C20	0.6	0.6	1.2	2.4	4.8	0.082	2.0	2.0
114 - 201	200:5*	C20	0.3	0.3	0.6	1.2	2.4	0.112	2.0	2.0
114 - 251	250:5*	C50	0.3	0.3	0.6	1.2	1.2	0.141	2.0	2.0
114 - 301	300:5*	C50	0.3	0.3	0.6	0.6	1.2	0.165	2.0	2.0
114 - 401	400:5*	C100	0.3	0.3	0.3	0.3	0.6	0.220	2.0	1.5
114 - 501	500:5*	C100	0.3	0.3	0.3	0.3	0.6	0.267	2.0	1.5
114 - 601	600:5*	C100	0.3	0.3	0.3	0.3	0.3	0.371	1.5	1.33
114 - 751	750:5*	C100	0.3	0.3	0.3	0.3	0.3	0.464	1.5	1.0
114 - 801	800:5*	C200	0.3	0.3	0.3	0.3	0.3	0.495	1.5	1.0
114 - 102	1000:5*	C100	0.3	0.3	0.3	0.3	0.3	0.597	1.5	1.0
114 - 122	1200:5*	C200	0.3	0.3	0.3	0.3	0.3	0.716	1.33	1.0
114 - 152	1500:5*	C200	0.3	0.3	0.3	0.3	0.3	0.896	1.0	0.8
114 - 162	1600:5*	C200	0.3	0.3	0.3	0.3	0.3	0.955	1.0	0.8

Model 115

Window Diameter 4.0"

Approximate weight: 19 lbs

Catalogue Number	Current Ratio	V.A. for ±1% class	ANSI Metering class at 60Hz					Secondary winding resistance (OHMS @ 75° C)	Continuous thermal rating factor	
			B0.1	B0.2	B0.5	B0.9	B1.8		@30° C	@55° C
115 - 500	50:5	-	2.4	4.8	-	-	-	0.025	2.0	2.0
115 - 750	75:5	-	1.2	2.4	4.8	-	-	0.037	2.0	2.0
115 - 101	100:5	C10	1.2	1.2	2.4	4.8	-	0.046	2.0	2.0
115 - 151	150:5*	C10	0.6	0.6	1.2	2.4	4.8	0.074	2.0	2.0
115 - 201	200:5*	C20	0.3	0.3	0.6	1.2	2.4	0.099	2.0	2.0
115 - 251	250:5*	C20	0.3	0.3	0.6	1.2	2.4	0.127	2.0	2.0
115 - 301	300:5*	C20	0.3	0.3	0.3	0.6	1.2	0.148	2.0	2.0
115 - 401	400:5*	C50	0.3	0.3	0.3	0.3	0.6	0.208	2.0	2.0
115 - 501	500:5*	C50	0.3	0.3	0.3	0.3	0.3	0.247	2.0	1.5
115 - 601	600:5*	C50	0.3	0.3	0.3	0.3	0.3	0.305	2.0	1.5
115 - 751	750:5*	C100	0.3	0.3	0.3	0.3	0.3	0.428	1.5	1.33
115 - 801	800:5*	C100	0.3	0.3	0.3	0.3	0.3	0.457	1.5	1.0
115 - 102	1000:5*	C100	0.3	0.3	0.3	0.3	0.3	0.571	1.5	1.0
115 - 122	1200:5*	C100	0.3	0.3	0.3	0.3	0.3	0.660	1.33	1.0
115 - 152	1500:5*	C100	0.3	0.3	0.3	0.3	0.3	0.825	1.0	0.8
115 - 162	1600:5*	C100	0.3	0.3	0.3	0.3	0.3	0.880	1.0	0.8
115 - 202	2000:5*	C200	0.3	0.3	0.3	0.3	0.3	1.100	1.0	0.8
115 - 252	2500:5*	C100	0.3	0.3	0.3	0.3	0.3	1.292	1.0	0.8
115 - 302	3000:5*	C200	0.3	0.3	0.3	0.3	0.3	1.550	0.8	0.6
115 - 322	3200:5*	C200	0.3	0.3	0.3	0.3	0.3	1.653	0.8	0.6

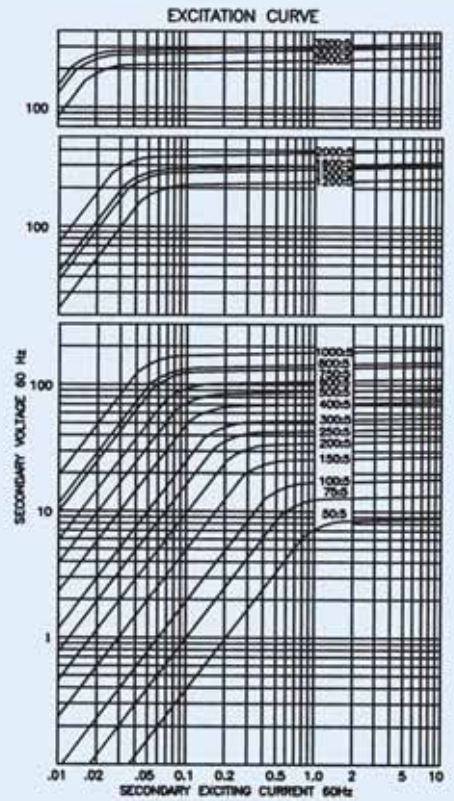

Model 117

Window Diameter 4.62"

Approximate weight: 13 lbs

Catalogue Number	Current Ratio	V.A. for ±1% class	ANSI Metering class at 60Hz					Secondary winding resistance (OHMS @ 75° C)	Continuous thermal rating factor	
			B0.1	B0.2	B0.5	B0.9	B1.8		@30° C	@55° C
117 - 500	50:5	-	2.4	-	-	-	-	0.015	2.0	2.0
117 - 750	75:5	-	2.4	2.4	-	-	-	0.024	2.0	2.0
117 - 101	100:5	-	1.2	2.4	4.8	-	-	0.043	2.0	2.0
117 - 151	150:5	C10	0.6	0.6	2.4	4.8	4.8	0.069	2.0	2.0
117 - 201	200:5	C10	0.6	0.6	1.2	2.4	4.8	0.085	2.0	2.0
117 - 251	250:5*	C20	0.6	0.6	0.6	1.2	2.4	0.106	2.0	2.0
117 - 301	300:5*	C20	0.3	0.3	0.6	1.2	2.4	0.145	2.0	2.0
117 - 401	400:5*	C20	0.3	0.3	0.3	0.6	1.2	0.184	2.0	2.0
117 - 501	500:5*	C20	0.3	0.3	0.3	0.3	0.6	0.236	2.0	1.5
117 - 601	600:5*	C20	0.3	0.3	0.3	0.3	0.6	0.283	2.0	1.5
117 - 751	750:5*	C50	0.3	0.3	0.3	0.3	0.3	0.354	1.5	1.33
117 - 801	800:5*	C50	0.3	0.3	0.3	0.3	0.3	0.425	1.5	1.33
117 - 102	1000:5*	C50	0.3	0.3	0.3	0.3	0.3	0.531	1.5	1.0
117 - 122	1200:5*	C100	0.3	0.3	0.3	0.3	0.3	0.637	1.33	1.0
117 - 152	1500:5*	C50	0.3	0.3	0.3	0.3	0.3	0.768	1.33	1.0
117 - 162	1600:5*	C50	0.3	0.3	0.3	0.3	0.3	0.819	1.0	0.8
117 - 202	2000:5*	C50	0.3	0.3	0.3	0.3	0.3	1.024	1.0	0.6
117 - 252	2500:5*	C100	0.3	0.3	0.3	0.3	0.3	1.279	1.0	0.6
117 - 302	3000:5*	-	0.3	0.3	0.3	0.3	0.3	1.428	1.0	0.6
117 - 322	3200:5*	-	0.3	0.3	0.3	0.3	0.3	1.523	1.0	0.6
117 - 402	4000:5*	-	0.3	0.3	0.3	0.3	0.3	2.385	0.8	0.6

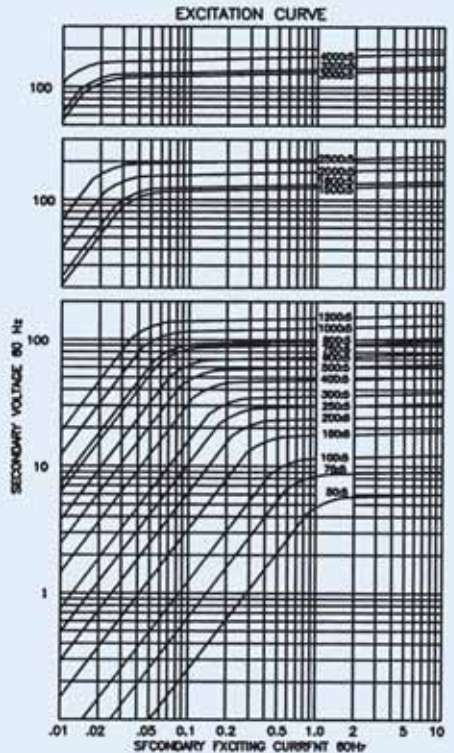

Application:
Relaying

Frequency:
50 - 400Hz

Insulation Level:
600 Volts, 10kV BIL full wave

Continuous Thermal Current Rating Factor:

See TRF at curve

- Terminals are brass studs No. 8 - 32 with one flat washer, lockwasher and regular nut
- The transformer winding is arranged so that the turns are fully distributed between all taps
- Order mounting bracket kit separately
- Approximate weight: 19 lbs

Approvals



Model 115MR

Window Diameter 4.0"

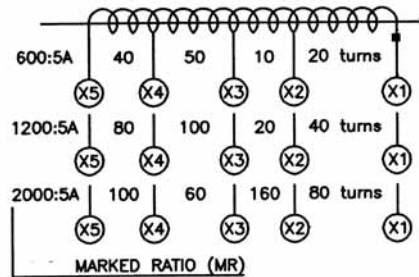
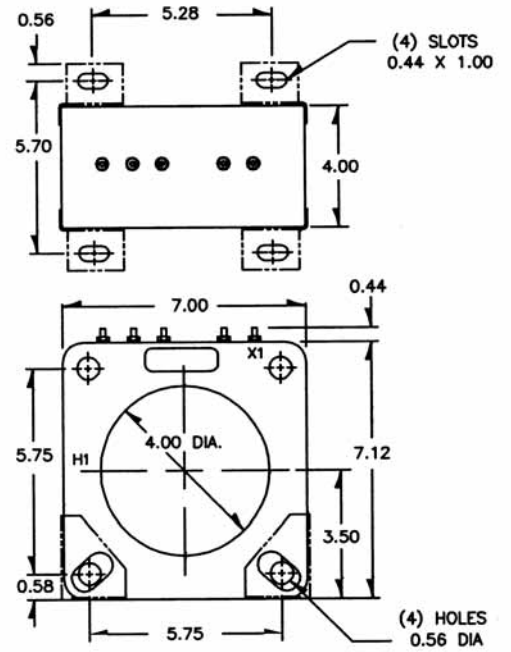
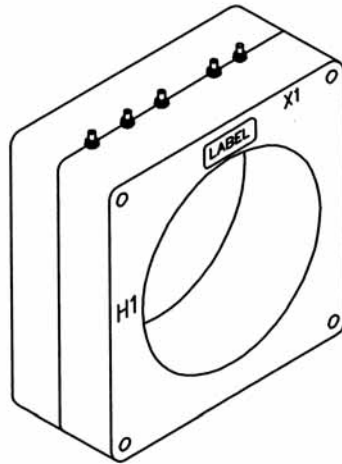

Models 112, 113 and 114 also available as MR

Models 112, 113, 114, 115, 117

Window Diameter 2.25", 2.75", 3.25", 4.0", 4.62"

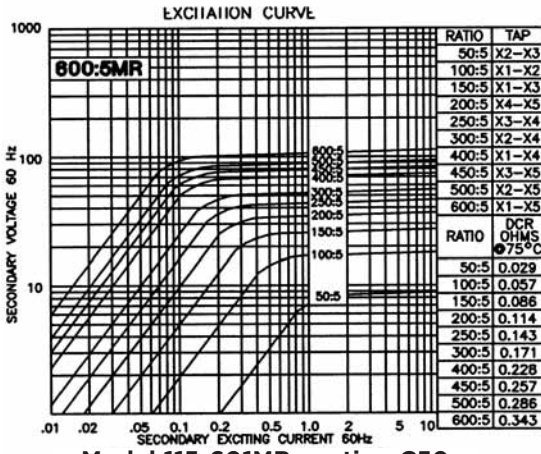

Model
115 - 601MR

Model 115-601MR - rating C50
TRF= 2.00 ● 30°C, 1.5 ● 55°C amb.

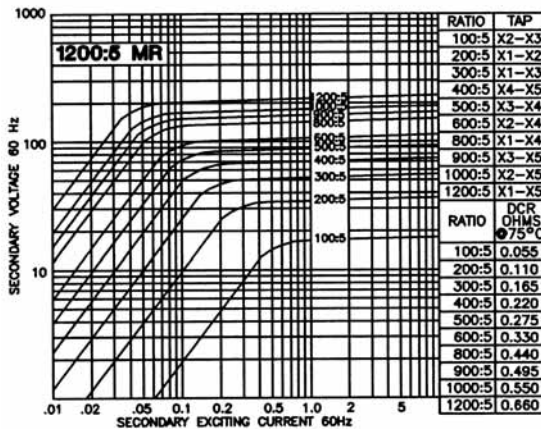

Model
115 - 122MR

Model 115-122MR - rating C100
TRF= 1.33 ● 30°C, 1.0 ● 55°C amb.

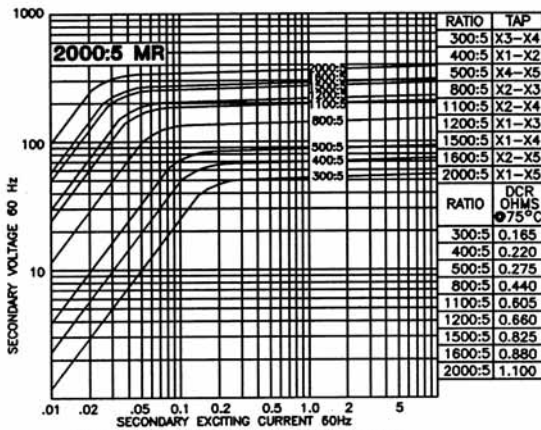

Model
115 - 202MR

Model 115-202MR - rating C200
TRF= 1.00 ● 30°C, 0.8 ● 55°C amb.

Application:
Relaying

Frequency:
50 - 400Hz

Insulation Level:
600 Volts, 10kV BIL full wave

Continuous Thermal Current Rating Factor:
See TRF at curve

- Terminals are brass studs No. 8 - 32 with one flat washer, lockwasher and regular nut
- The transformer winding is arranged so that the turns are fully distributed between all taps
- Order mounting bracket kit separately
- Approximate weight: 13 lbs

Approvals



Model 117MR

Window Diameter 4.62"

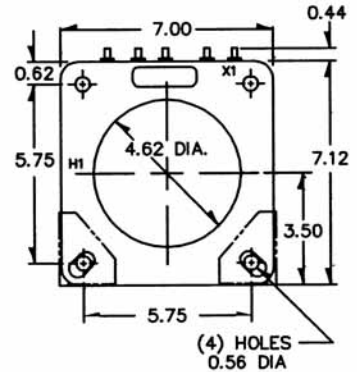
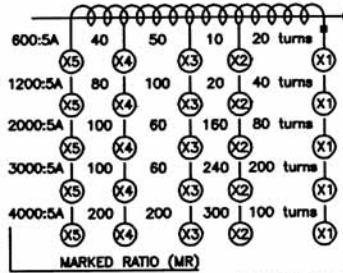
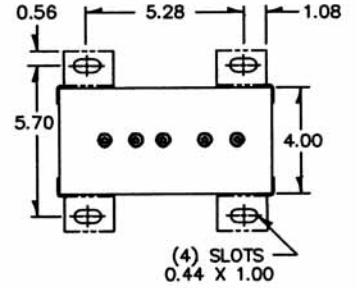
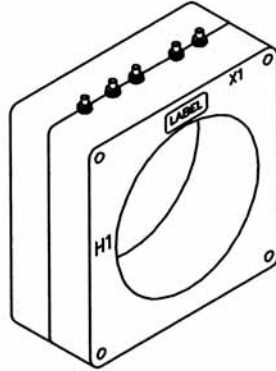

EXCITATION CURVE

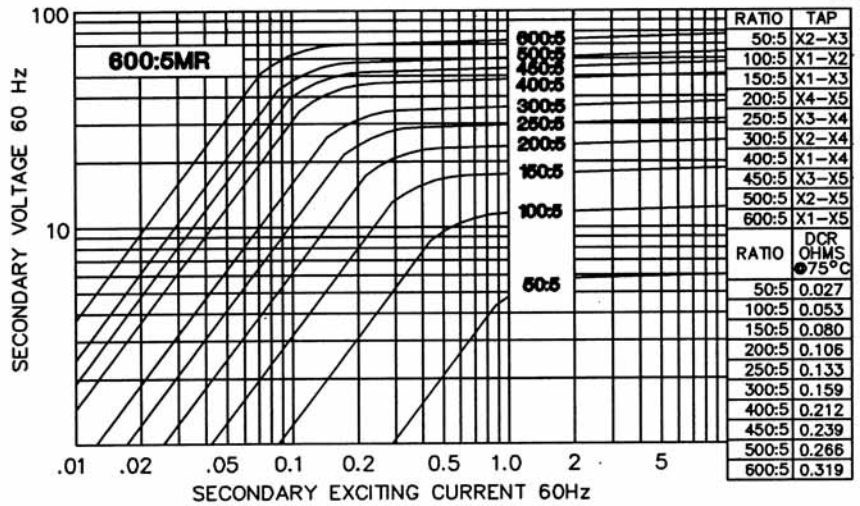

Model 117-601MR - rating C20

TRF= 2.0 @ 30°C, 1.5 @ 55°C amb.

Model 117 - 122MR

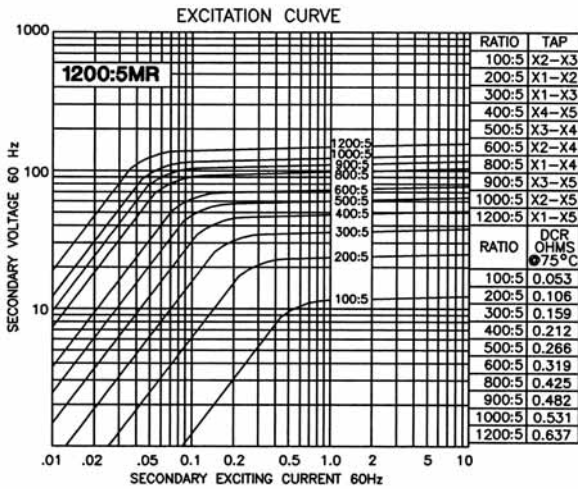

Model 117-202MR - rating C100

TRF= 1.33 ● 30°C, 1.0 ● 55°C amb.

Model 117 - 202MR

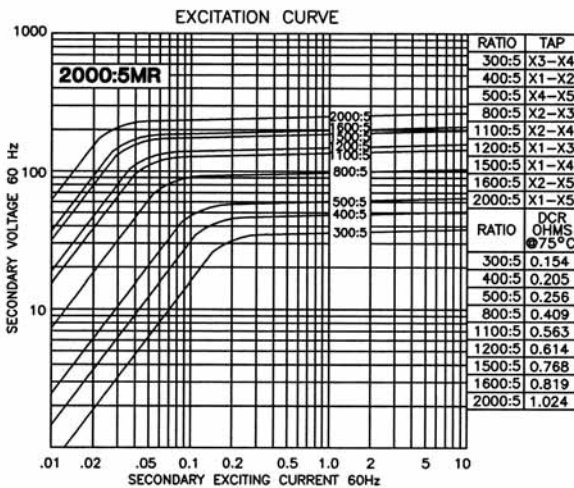

Model 117-202MR - rating C100

TRF= 1.00 ● 30°C, 0.6 ● 55°C amb.

Application:

Relaying and metering

Frequency:

50 - 400Hz

Insulation Level:

600 Volts, 10kV BIL full wave

- Terminals are brass studs No. 8 - 32 with one flat washer, lockwasher and regular nut
- Multi ratios available upon request
- Order mounting bracket kit separately
- Approximate weight: 11 lbs

Approvals



Model 120

Window Diameter 5.75"

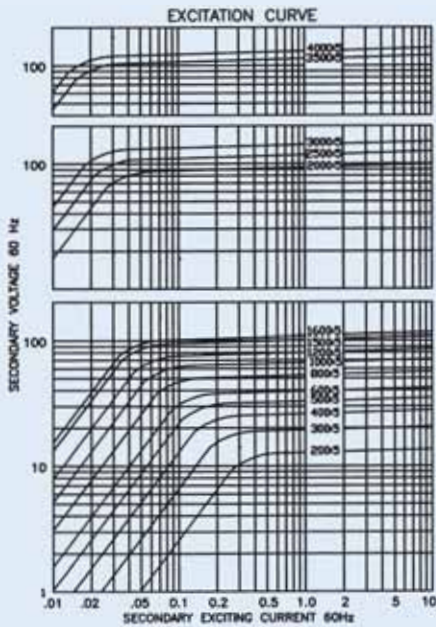
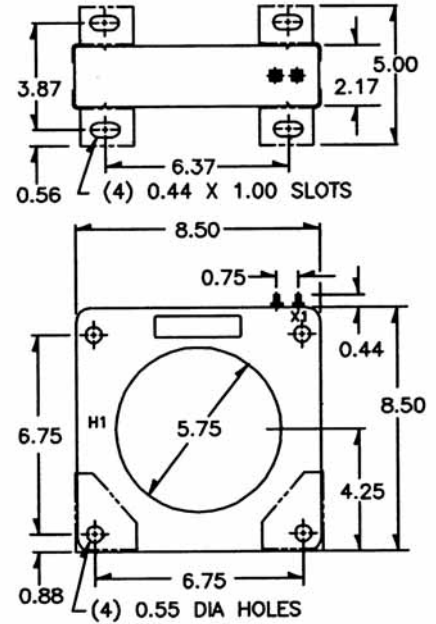
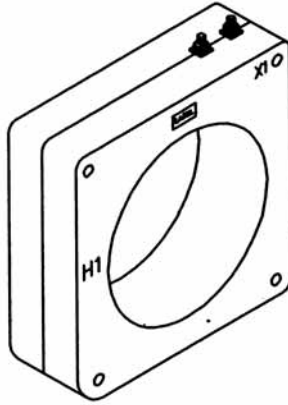

Catalogue Number	Current Ratio	Relay Class	ANSI metering class at 60Hz					Secondary winding resistance (OHMS @ 75 °C)	Continuous thermal rating factor	
			B0.1	B0.2	B0.5	B0.9	B1.8		@30 °C	@55 °C
120 - 201	200:5	-	1.2	1.2	2.4	4.8	4.8	0.053	2.0	2.0
120 - 301	300:5*	C10	0.3	0.6	1.2	2.4	2.4	0.063	2.0	2.0
120 - 401	400:5*	C10	0.3	0.3	0.6	1.2	2.4	0.080	2.0	2.0
120 - 501	500:5*	C20	0.3	0.3	0.3	0.6	1.2	0.137	2.0	2.0
120 - 601	600:5*	C20	0.3	0.3	0.3	0.6	0.6	0.165	2.0	2.0
120 - 801	800:5*	C20	0.3	0.3	0.3	0.3	0.6	0.220	2.0	1.5
120 - 102	1000:5*	C20	0.3	0.3	0.3	0.3	0.3	0.309	1.5	1.5
120 - 122	1200:5*	C50	0.3	0.3	0.3	0.3	0.3	0.371	1.5	1.33
120 - 152	1500:5*	C50	0.3	0.3	0.3	0.3	0.3	0.464	1.5	1.0
120 - 162	1600:5*	C50	0.3	0.3	0.3	0.3	0.3	0.494	1.33	1.0
120 - 202	2000:5*	C50	0.3	0.3	0.3	0.3	0.3	0.592	1.33	1.0
120 - 252	2500:5*	C50	0.3	0.3	0.3	0.3	0.3	0.740	1.0	0.8
120 - 302	3000:5*	C50	0.3	0.3	0.3	0.3	0.3	0.888	1.0	0.8
120 - 352	3500:5	C20	0.3	0.3	0.3	0.3	0.3	0.964	1.0	0.8
120 - 402	4000:5*	C50	0.3	0.3	0.3	0.3	0.3	1.102	1.0	0.8

Model 125

Window Diameter 6.31"

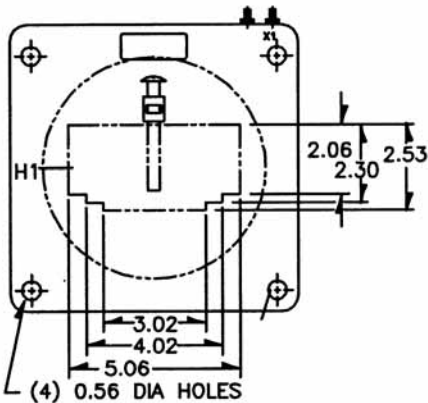
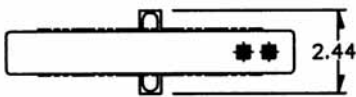
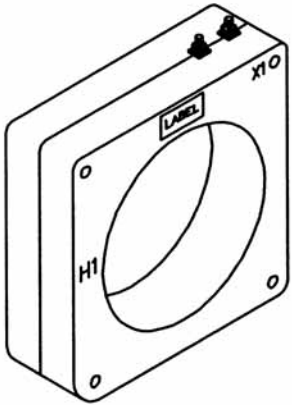

(BUS BAR MOUNTING KIT SHOWN)

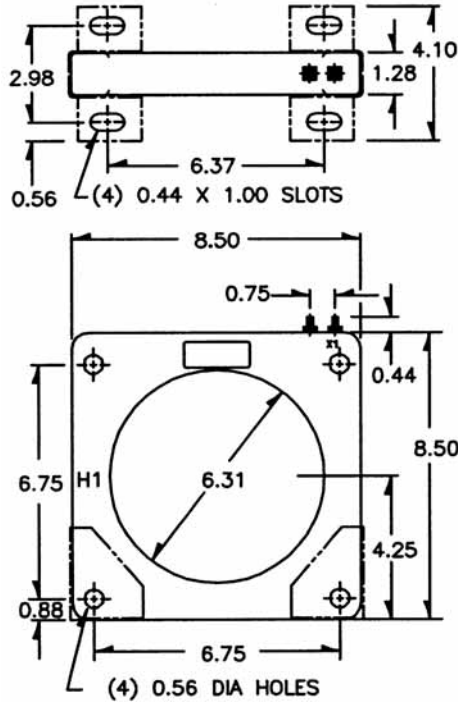

Application:
Marketing

Frequency:
50 - 400Hz

Insulation Level:

- 600 Volts, 10kV BIL full wave
- Terminals are brass studs No. 8 - 32 with one flatwasher, lockwasher and regular nut
- Order mounting bracket kit separately
- Order busbar mounting kit 1021D00135, separately, factory installed
- Approximate weight: 3 lbs

Approvals



Catalogue Number	Current Ratio	ANSI metering class at 60Hz					Secondary winding resistance (OHMS @ 75°C)	Continuous thermal rating factor	
		B0.1	B0.2	B0.5	B0.9	B1.8		@30°C	@55°C
125 - 601	600:5	0.3	0.3	1.2	1.2	2.4	0.071	1.5	1.33
125 - 751	750:5	0.3	0.3	0.6	1.2	2.4	0.143	1.5	1.33
125 - 801	800:5	0.3	0.3	0.6	1.2	2.4	0.116	1.5	1.33
125 - 102	1000:5	0.3	0.3	0.3	0.6	1.2	0.187	1.5	1.33
125 - 122	1200:5	0.3	0.3	0.3	0.6	1.2	0.224	1.5	1.55
125 - 152	1500:5	0.3	0.3	0.3	0.3	0.6	0.285	1.5	1.33
125 - 162	1600:5	0.3	0.3	0.3	0.3	0.6	0.304	1.5	1.33
125 - 202	2000:5	0.3	0.3	0.3	0.3	0.6	0.280	1.5	1.0
125 - 252	2500:5	0.3	0.3	0.3	0.3	0.6	0.351	1.33	1.0
125 - 302	3000:5	0.3	0.3	0.3	0.3	0.6	0.421	1.33	1.0
125 - 352	3500:5	0.3	0.3	0.3	0.3	0.3	0.491	1.33	1.0
125 - 402	4000:5	0.3	0.3	0.3	0.3	0.3	0.696	1.0	0.8

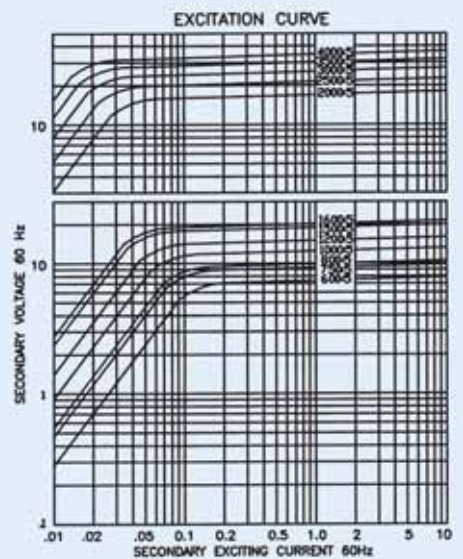

Application:
Metering

Frequency:
50 - 400Hz

Insulation Level:

600 Volts, 10kV BIL full wave

- Terminals are brass studs No. 10 - 32 with one flatwasher, lockwasher and regular nut
- Multi ratios available upon request
- Order mounting bracket kit separately
- Approximately weight: 5.5 lbs

Approvals



Model 128

Window Diameter 8.25"

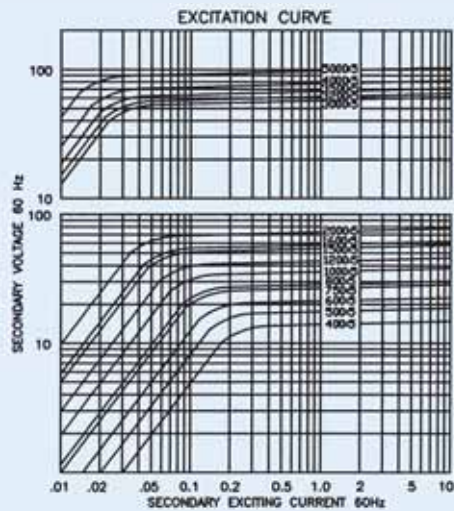
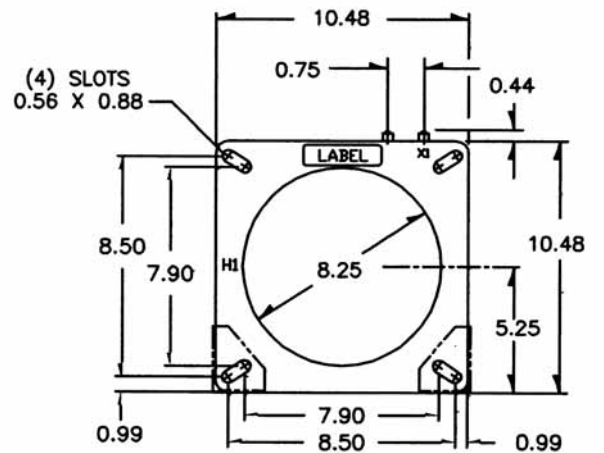
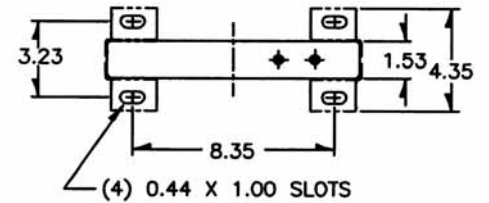
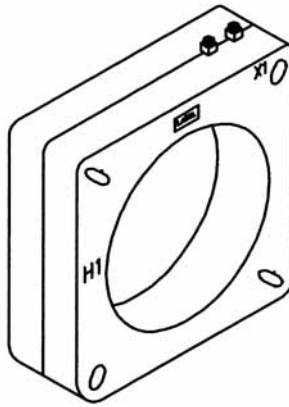

Catalogue Number	Current Ratio	Relay Class	ANSI metering class at 60Hz					Secondary winding resistance (OHMS @ 75 °C)	Continuous thermal rating factor	
			B0.1	B0.2	B0.5	B0.9	B1.8		@30 °C	@55 °C
120 - 201	200:5	-	1.2	1.2	2.4	4.8	4.8	0.053	2.0	2.0
126 - 401	400:5	4.0	0.6	1.2	1.2	2.4	4.8	0.166	2.0	2.0
126 - 501	500:5	7.5	0.6	0.6	1.2	1.2	2.4	0.145	2.0	2.0
126 - 601	600:5	10.0	0.6	0.6	0.6	1.2	2.4	0.173	2.0	2.0
126 - 751	750:5	15.0	0.3	0.3	0.6	0.6	1.2	0.217	2.0	1.5
126 - 801	800:5	20.0	0.3	0.3	0.6	0.6	1.2	0.231	2.0	1.5
126 - 102	1000:5	25.0	0.3	0.3	0.3	0.6	0.6	0.289	2.0	1.5
126 - 122	1200:5	40.0	0.3	0.3	0.3	0.3	0.3	0.347	1.5	1.33
126 - 152	1500:5	50.0	0.3	0.3	0.3	0.3	0.3	0.434	1.5	1.0
126 - 162	1600:5	50.0	0.3	0.3	0.3	0.3	0.3	0.462	1.5	1.0
126 - 202	2000:5	60.0	0.3	0.3	0.3	0.3	0.3	0.578	1.33	1.0
126 - 252	2500:5	75.0	0.3	0.3	0.3	0.3	0.3	0.904	1.0	0.8
126 - 302	3000:5	90.0	0.3	0.3	0.3	0.3	0.3	0.722	1.33	1.0
126 - 322	3200:5	95.0	0.3	0.3	0.3	0.3	0.3	0.770	1.33	1.0
126 - 352	3500:5	100.0	0.3	0.3	0.3	0.3	0.3	0.842	1.0	0.8
126 - 402	4000:5	125.0	0.3	0.3	0.3	0.3	0.3	0.962	1.0	0.8
126 - 502	5000:5	140.0	0.3	0.3	0.3	0.3	0.3	1.203	1.0	0.8

Model 130

Window Diameter 5.75"

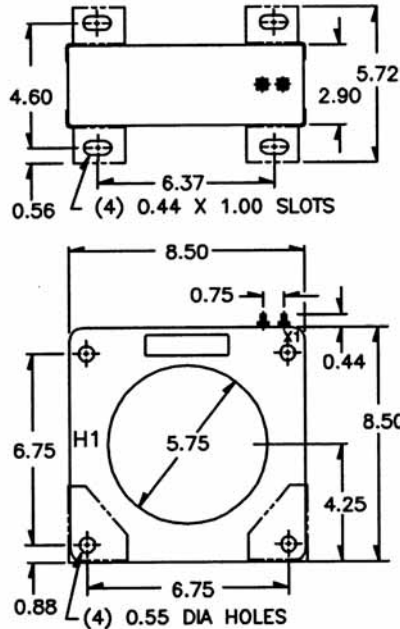
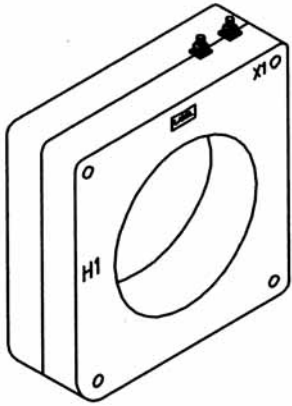

Application:

Relaying and metering

Frequency:

50 - 400Hz

Insulation Level:

600 Volts, 10kV BIL full wave

- Terminals are brass studs No. 8 - 32 with one flatwasher, lockwasher and regular nut
- Order mounting bracket kit separately
- Other ratios and Multi-ratios available upon request
- Approximately weight: 18 lbs

Approvals



Catalogue Number	Current Ratio	Relay Class	ANSI metering class at 60Hz					Secondary winding resistance (OHMS @ 75° C)	Continuous thermal rating factor	
			B0.1	B0.2	B0.5	B0.9	B1.8		@30° C	@55° C
120 - 201	200:5	-	1.2	1.2	2.4	4.8	4.8	0.053	2.0	2.0
130 - 201	200:5	C10	0.6	0.6	2.4	2.4	4.8	0.064	2.0	2.0
130 - 301	300:5	C20	0.3	0.3	1.2	1.2	2.4	0.105	2.0	2.0
130 - 401	400:5	C20	0.3	0.3	0.6	1.2	1.2	0.140	2.0	2.0
130 - 501	500:5	C20	0.3	0.3	0.3	0.6	1.2	0.175	2.0	2.0
130 - 601	600:5	C20	0.3	0.3	0.3	0.6	1.2	0.210	2.0	1.5
130 - 801	800:5	C50	0.3	0.3	0.3	0.3	0.6	0.324	2.0	1.5
130 - 102	1000:5	C50	0.3	0.3	0.3	0.3	0.3	0.404	1.5	1.33
130 - 122	1200:5	C50	0.3	0.3	0.3	0.3	0.3	0.485	1.5	1.0
130 - 152	1500:5	C100	0.3	0.3	0.3	0.3	0.3	0.607	1.5	1.0
130 - 162	1600:5	C100	0.3	0.3	0.3	0.3	0.3	0.647	1.33	1.0
130 - 202	2000:5	C100	0.3	0.3	0.3	0.3	0.3	0.783	1.33	1.0
130 - 252	2500:5	C100	0.3	0.3	0.3	0.3	0.3	0.979	1.0	0.8
130 - 302	3000:5	C100	0.3	0.3	0.3	0.3	0.3	1.175	1.0	0.8
130 - 402	4000:5	C100	0.3	0.3	0.3	0.3	0.3	1.484	1.0	0.6

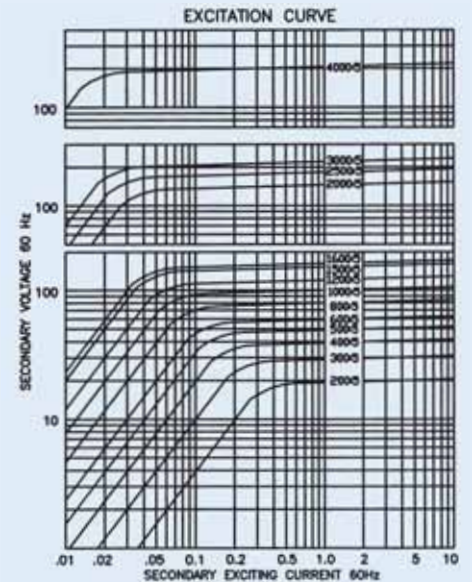

Application:

Relaying and metering

Frequency:

50 - 400Hz

Insulation Level:

600 Volts, 10kV BIL full wave

- Terminals are brass studs No. 10 - 32 with one flatwasher, lockwasher and regular nut
- Multi ratios available upon request
- Order mounting bracket kit separately
- Approximately weight: 18 lbs

Approvals



Model 135

Window Diameter 5.75"

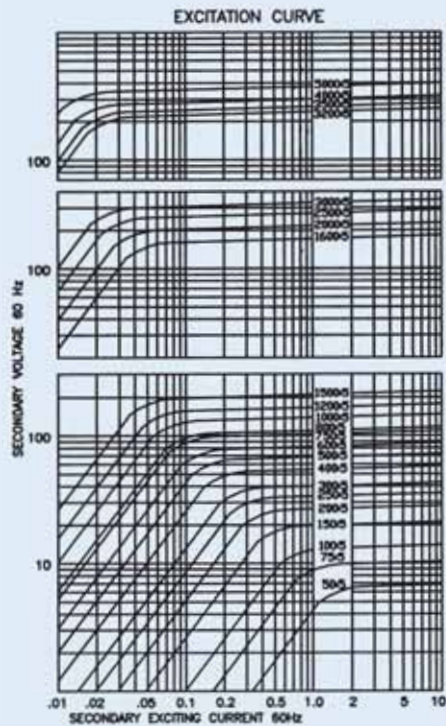
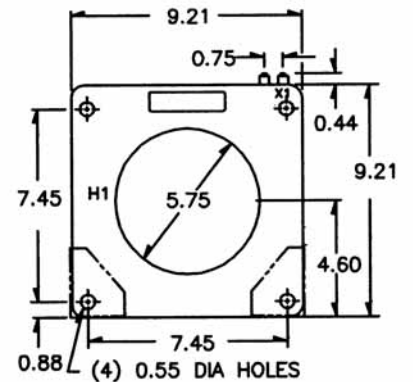
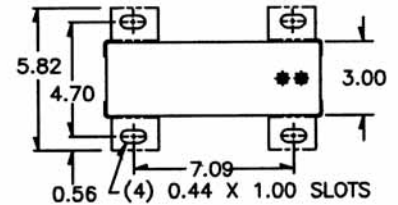
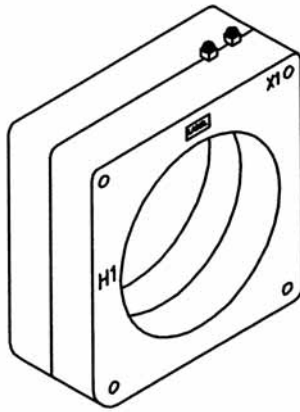

Catalogue Number	Current Ratio	Relay Class	ANSI metering class at 60Hz					Secondary winding resistance (OHMS @ 75 °C)	Continuous thermal rating factor	
			B0.1	B0.2	B0.5	B0.9	B1.8		@30 °C	@55 °C
120 - 201	200:5	-	1.2	1.2	2.4	4.8	4.8	0.053	2.0	2.0
135 - 500	50:5	-	4.8	-	-	-	-	0.015	2.0	2.0
135 - 750	75:5	-	2.4	4.8	-	-	-	0.027	2.0	2.0
135 - 101	100:5	-	1.2	2.4	4.8	-	-	0.036	2.0	2.0
135 - 151	150:5	C10	0.6	1.2	2.4	4.8	-	0.059	2.0	2.0
135 - 201	200:5*	C10	0.6	0.6	1.2	2.4	4.8	0.078	2.0	2.0
135 - 251	250:5*	C20	0.6	0.6	1.2	2.4	2.4	0.113	2.0	2.0
135 - 301	300:5*	C20	0.3	0.3	0.6	1.2	2.4	0.117	2.0	2.0
135 - 401	400:5*	C20	0.3	0.3	0.3	0.6	1.2	0.156	2.0	2.0
135 - 501	500:5*	C50	0.3	0.3	0.3	0.3	0.6	0.181	2.0	2.0
135 - 601	600:5*	C50	0.3	0.3	0.3	0.3	0.6	0.217	2.0	2.0
135 - 751	750:5*	C50	0.3	0.3	0.3	0.3	0.6	0.339	2.0	1.5
135 - 801	800:5*	C50	0.3	0.3	0.3	0.3	0.6	0.362	2.0	1.5
135 - 102	1000:5*	C100	0.3	0.3	0.3	0.3	0.3	0.452	1.5	1.33
135 - 122	1200:5*	C100	0.3	0.3	0.3	0.3	0.3	0.543	1.5	1.33
135 - 152	1500:5*	C100	0.3	0.3	0.3	0.3	0.3	0.678	1.5	1.0
135 - 162	1600:5*	C100	0.3	0.3	0.3	0.3	0.3	0.694	1.5	1.0
135 - 202	2000:5*	C100	0.3	0.3	0.3	0.3	0.3	0.867	1.33	1.0
135 - 252	2500:5*	C200	0.3	0.3	0.3	0.3	0.3	1.084	1.0	0.8
135 - 302	3000:5*	C200	0.3	0.3	0.3	0.3	0.3	1.301	1.0	0.8
135 - 322	3200:5*	C200	0.3	0.3	0.3	0.3	0.3	1.279	1.0	0.8
135 - 352	3500:5*	C200	0.3	0.3	0.3	0.3	0.3	1.399	1.0	0.8
135 - 402	4000:5*	C200	0.3	0.3	0.3	0.3	0.3	1.598	1.0	0.6
135 - 502	5000:5*	C200	0.3	0.3	0.3	0.3	0.3	2.459	1.0	0.6

Model 135MR

Window Diameter 5.75"

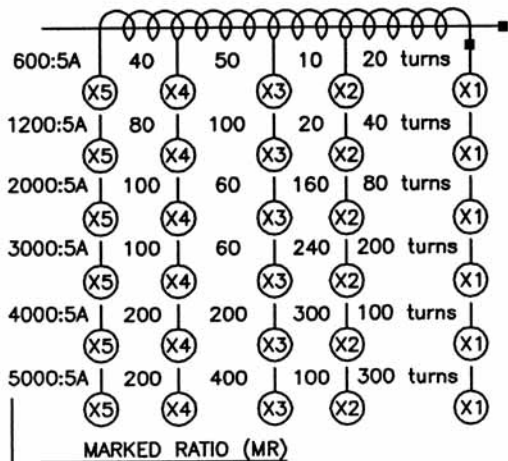
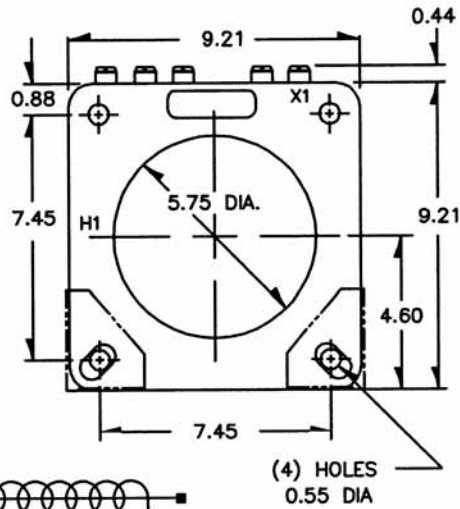
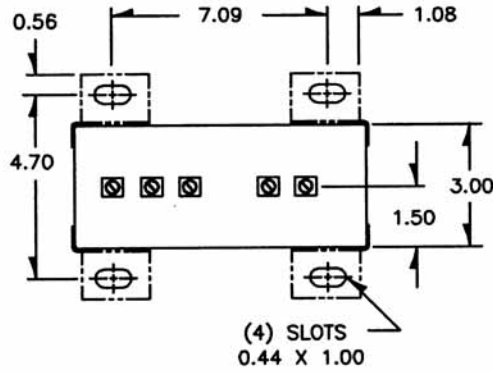
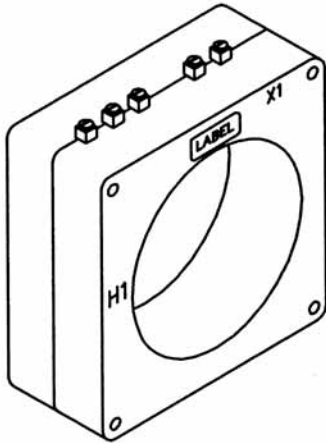

Application:
Relaying

Frequency:
50 - 400Hz

Insulation Level:
600 Volts, 10kV BIL full wave

- Continuous Thermal Current Rating Factor:**
See TRF at curve
- Terminals are brass studs No. 10 - 32 with one flat washer, lockwasher and regular nut
 - The transformer winding is arranged so that the turns are fully distributed between all taps
 - Order mounting bracket kit separately
 - Approximate weight: 18 lbs

Approvals



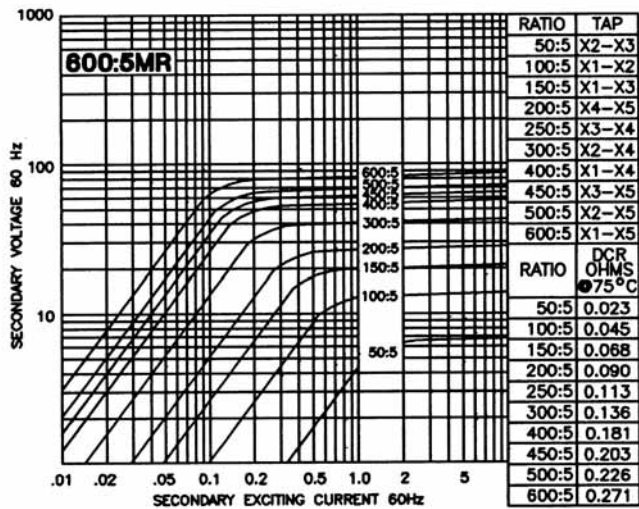

Model 135-60MR - rating C50

TRF= 2.0 @ 30°C, 2.0 @ 55°C amb.

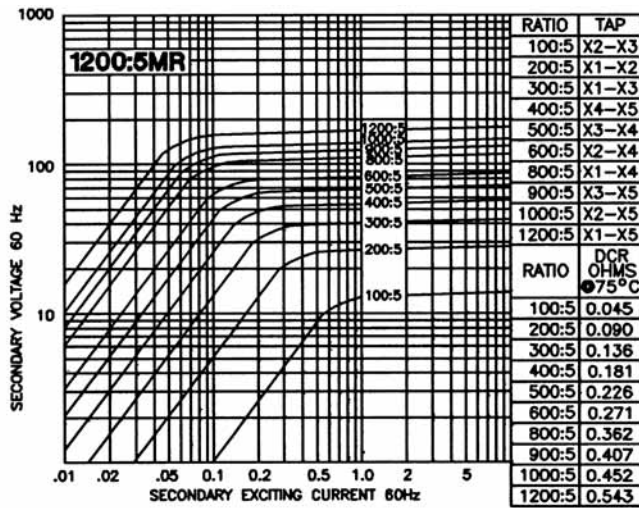

Model 135-122MR - rating C100

TRF= 1.5 @ 30°C, 1.33 @ 55°C amb.

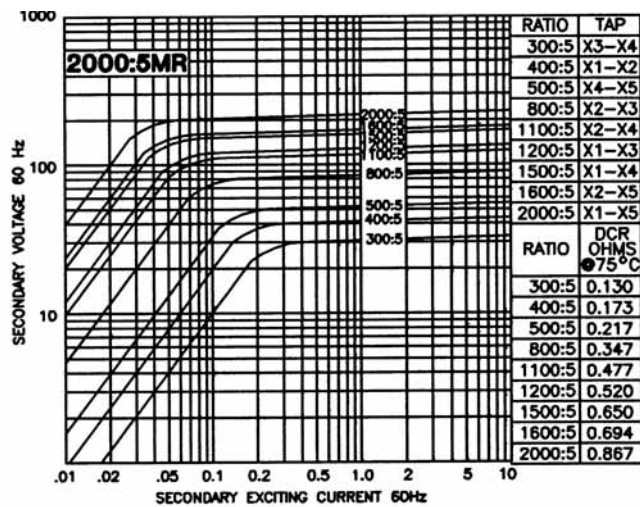

Model 135-202MR - rating C100

TRF= 1.0 @ 30°C, 0.8 @ 55°C amb.

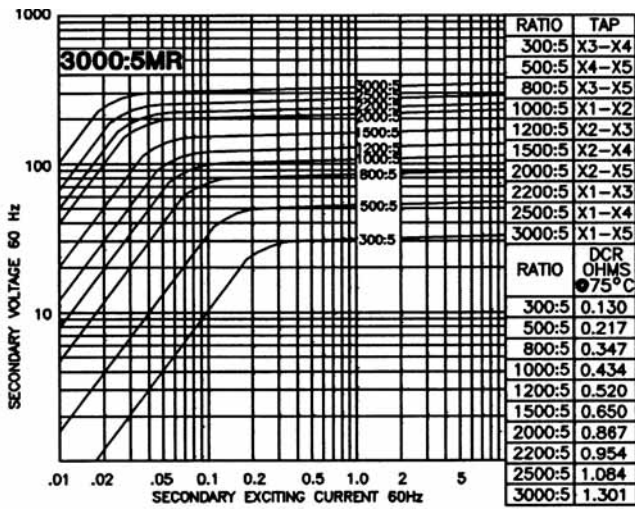

Model 135-302MR - rating C200
 TRF= 1.0 @ 30°C, 0.8 @ 55°C amb.

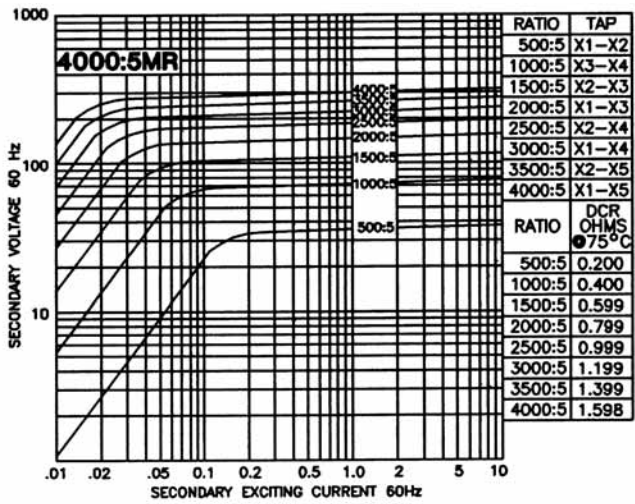

Model 135-402MR - rating C200
 TRF= 1.0 @ 30°C, 0.6 @ 55°C amb.

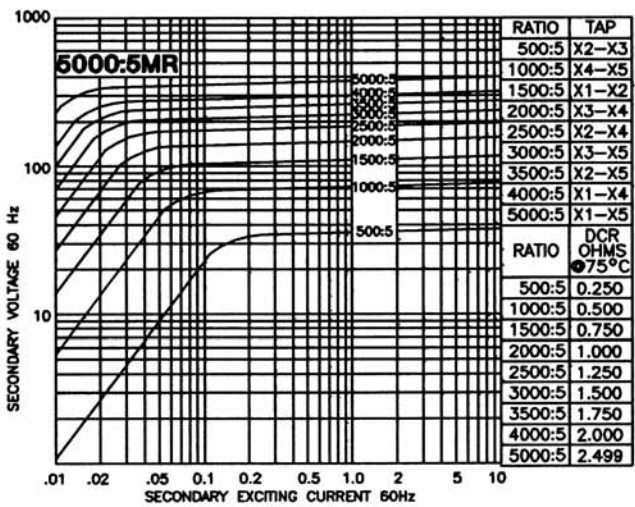

Model 135-502MR - rating C200
 TRF= 1.0 @ 30°C, 0.6 @ 55°C amb.

Application:

Relaying and metering

Frequency:

50 - 400Hz

Insulation Level:

600 Volts, 10kV BIL full wave

- Terminals are brass studs No. 10 - 32 with one flatwasher, lockwasher and regular nut
- Multi ratios available upon request
- Order mounting bracket kit separately
- Approximately weight: 50 lbs

Approvals



Model 137

Window Diameter 5.50"

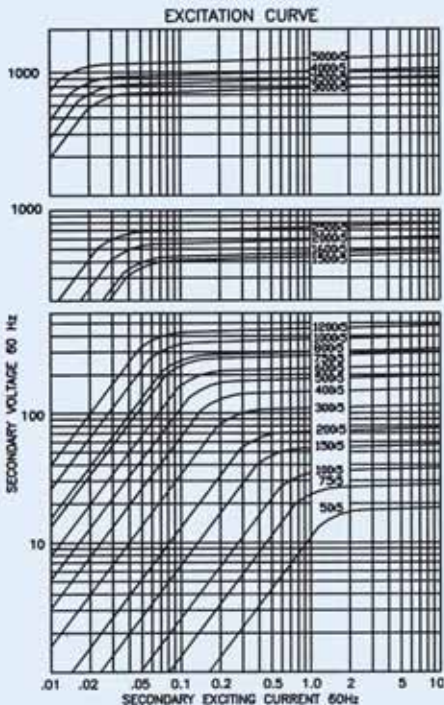
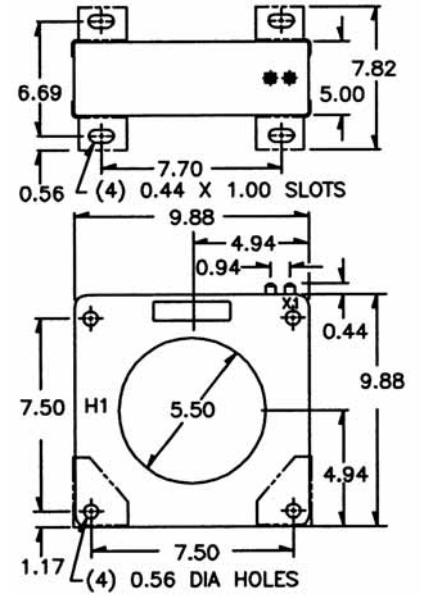
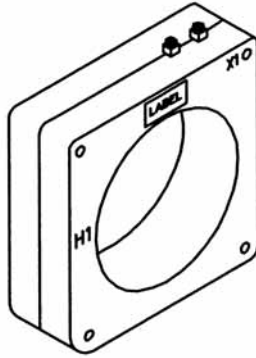

Catalogue Number	Current Ratio	Relay Class	ANSI metering class at 60Hz					Secondary winding resistance (OHMS @ 75°C)	Continuous thermal rating factor	
			B0.1	B0.2	B0.5	B0.9	B1.8		@30°C	@55°C
137 - 500	50:5	C10	2.4	4.8	-	-	-	0.019	2.0	2.0
137 - 750	75:5	C20	1.2	2.4	4.8	-	-	0.029	2.0	2.0
137 - 101	100:5	C20	1.2	1.2	2.4	4.8	-	0.039	2.0	2.0
137 - 151	150:5*	C20	0.6	0.6	1.2	2.4	4.8	0.058	2.0	2.0
137 - 201	200:5*	C50	0.3	0.6	1.2	1.2	2.4	0.078	2.0	2.0
137 - 251	250:5*	C50	0.3	0.3	0.6	1.2	1.2	0.097	2.0	2.0
137 - 301	300:5*	C100	0.3	0.3	0.6	0.6	1.2	0.116	2.0	2.0
137 - 401	400:5*	C100	0.3	0.3	0.3	0.3	0.6	0.155	2.0	2.0
137 - 501	500:5*	C100	0.3	0.3	0.3	0.3	0.6	0.194	2.0	2.0
137 - 601	600:5*	C200	0.3	0.3	0.3	0.3	0.3	0.233	2.0	2.0
137 - 751	750:5*	C200	0.3	0.3	0.3	0.3	0.3	0.291	2.0	2.0
137 - 801	800:5*	C200	0.3	0.3	0.3	0.3	0.3	0.390	2.0	2.0
137 - 102	1000:5*	C200	0.3	0.3	0.3	0.3	0.3	0.488	2.0	1.5
137 - 122	1200:5*	C400	0.3	0.3	0.3	0.3	0.3	0.585	2.0	1.5
137 - 152	1500:5*	C400	0.3	0.3	0.3	0.3	0.3	0.678	1.5	1.33
137 - 162	1600:5*	C400	0.3	0.3	0.3	0.3	0.3	0.723	1.5	1.33
137 - 202	2000:5*	C400	0.3	0.3	0.3	0.3	0.3	0.903	1.5	1.0
137 - 252	2500:5*	C400	0.3	0.3	0.3	0.3	0.3	1.129	1.5	1.0
137 - 302	3000:5*	C400	0.3	0.3	0.3	0.3	0.3	1.279	1.33	1.0
137 - 352	3500:5*	C400	0.3	0.3	0.3	0.3	0.3	1.492	1.0	0.8
137 - 402	4000:5*	C400	0.3	0.3	0.3	0.3	0.3	2.136	1.0	0.8
137 - 502	5000:5*	C400	0.3	0.3	0.3	0.3	0.3	4.199	0.6	0.3

Model 137MR

Window Diameter 5.50"

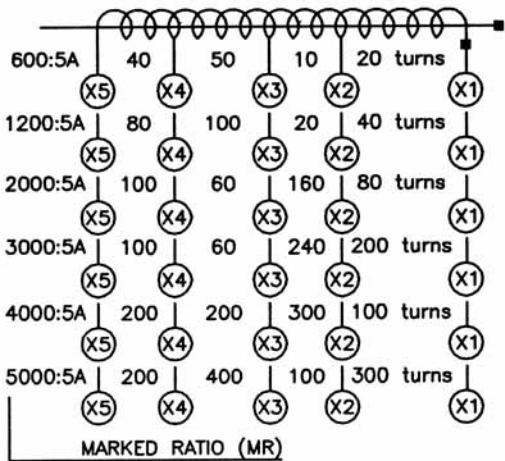
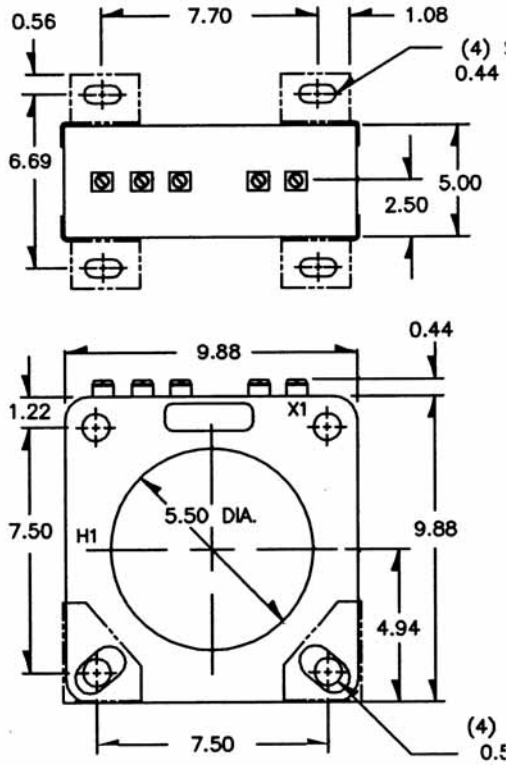
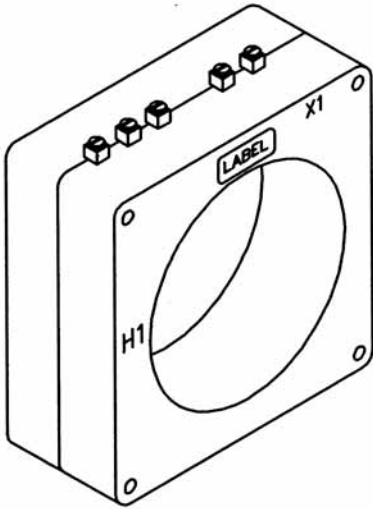

Application:
Relaying

Frequency:
50 - 400Hz:

Insulation Level:
600 Volts, 10kV BIL full wave

- Continuous Thermal Current Rating Factor:**
See TRF at curve
- Terminals are brass studs No. 10 - 32 with one flat washer, lockwasher and regular nut
 - The transformer winding is arranged so that the turns are fully distributed between all taps
 - Order mounting bracket kit separately
 - Approximate weight: 50 lbs

Approvals



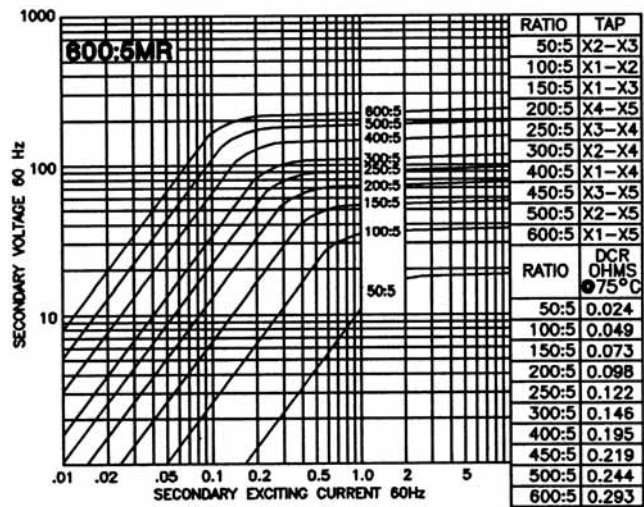

Model 137-60MR - rating C200
 TRF= 2.0 @ 30°C, 2.0 @ 55°C amb.

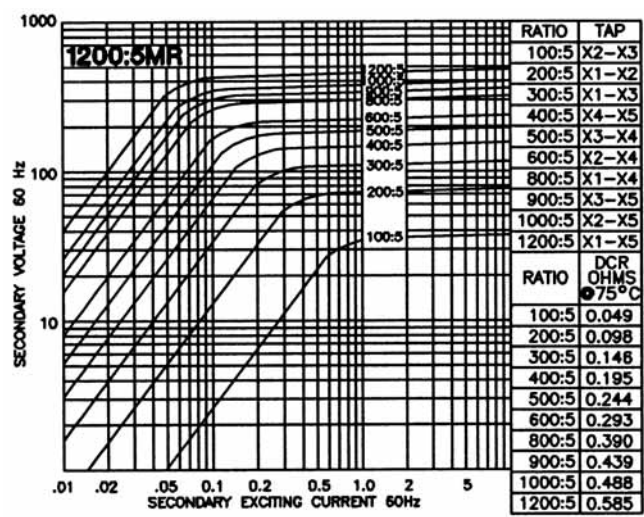

Model 137-122MR - rating C400
 TRF= 2.0 @ 30°C, 1.5 @ 55°C amb.

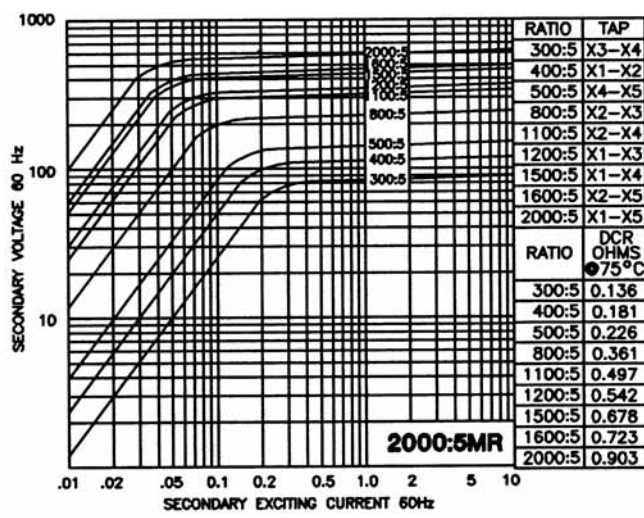

Model 137-202MR - rating C400
 TRF= 1.5 @ 30°C, 1.0 @ 55°C amb.

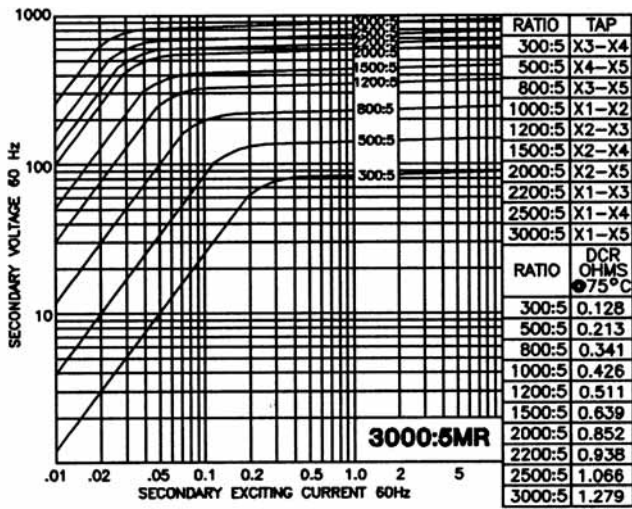

Model 137-202MR - rating C400

TRF = 1.33 @ 30°C, 1.0 @ 55°C amb.

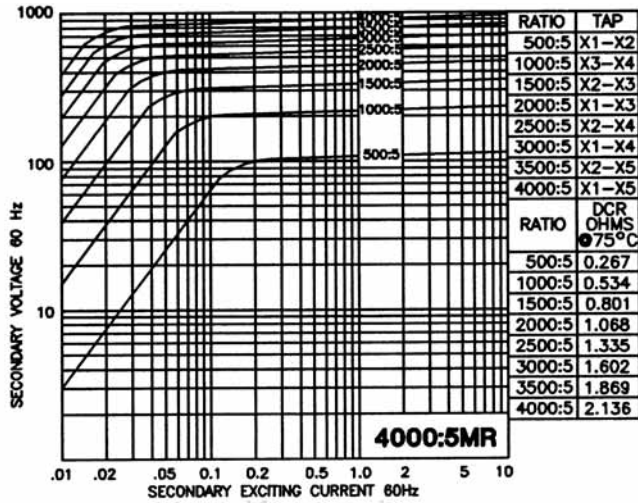

Model 135-402MR - rating C400

TRF = 1.0 @ 30°C, 0.8 @ 55°C amb.

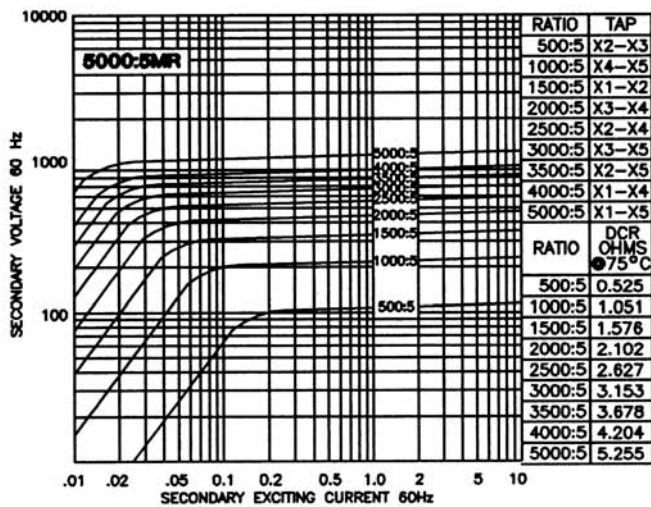

Model 135-502MR - rating C400

TRF = 0.6 @ 30°C, 0.3 @ 55°C amb.

Application:

Relaying and metering

Frequency:

50 - 400Hz:

Insulation Level:

600 Volts, 10kV BIL full wave

- Terminals are brass studs No. 10 - 32 with one flatwasher, lockwasher and regular nut
- Multi ratios available upon request
- Order mounting bracket kit separately
- Approximately weight: 40 lbs

Approvals



Model 139

Window Diameter 6.50"

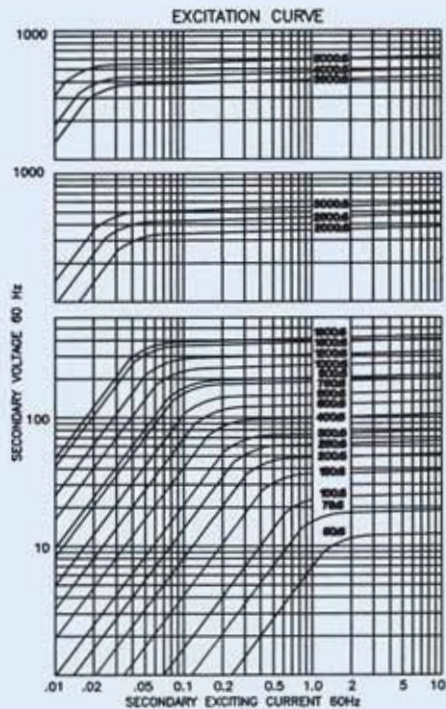
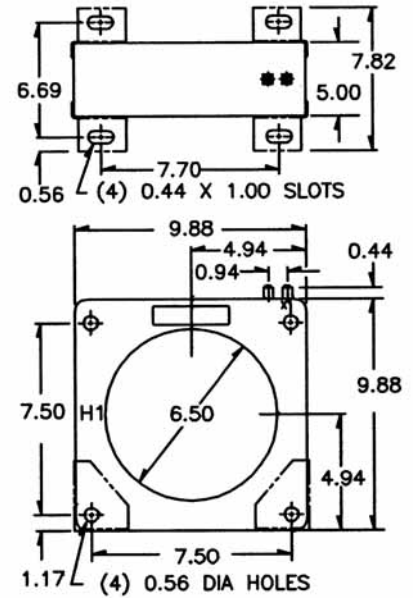
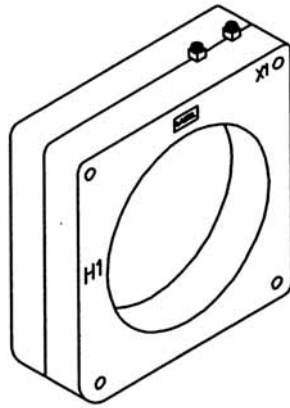

Catalogue Number	Current Ratio	Relay Class	ANSI metering class at 60Hz					Secondary winding resistance (OHMS @ 75 °C)	Continuous thermal rating factor	
			B0.1	B0.2	B0.5	B0.9	B1.8		@30 °C	@55 °C
139 - 500	50:5	C10	4.8	-	-	-	-	0.018	2.0	2.0
139 - 750	75:5	C10	2.4	4.8	-	-	-	0.027	2.0	2.0
139 - 101	100:5	C20	1.2	2.4	4.8	4.8	-	0.036	2.0	2.0
139 - 151	150:5	C20	0.6	1.2	2.4	2.4	4.8	0.053	2.0	2.0
139 - 201	200:5	C20	0.6	0.6	1.2	2.4	2.4	0.071	2.0	2.0
139 - 251	250:5	C50	0.3	0.6	1.2	1.2	2.4	0.089	2.0	2.0
139 - 301	300:5	C50	0.3	0.3	0.6	1.2	1.2	0.107	2.0	2.0
139 - 401	400:5	C50	0.3	0.3	0.3	0.6	1.2	0.142	2.0	2.0
139 - 501	500:5	C100	0.3	0.3	0.3	0.3	0.6	0.178	2.0	2.0
139 - 601	600:5	C100	0.3	0.3	0.3	0.3	0.6	0.214	2.0	2.0
139 - 751	750:5	C100	0.3	0.3	0.3	0.3	0.3	0.267	2.0	2.0
139 - 801	800:5	C100	0.3	0.3	0.3	0.3	0.3	0.285	2.0	2.0
139 - 102	1000:5	C200	0.3	0.3	0.3	0.3	0.3	0.563	1.5	1.5
139 - 122	1200:5	C200	0.3	0.3	0.3	0.3	0.3	0.676	1.5	1.33
139 - 152	1500:5	C200	0.3	0.3	0.3	0.3	0.3	0.845	1.5	1.0
139 - 162	1600:5	C200	0.3	0.3	0.3	0.3	0.3	0.901	1.5	1.0
139 - 202	2000:5	C200	0.3	0.3	0.3	0.3	0.3	0.823	1.5	1.0
139 - 252	2500:5	C200	0.3	0.3	0.3	0.3	0.3	1.029	1.5	1.0
139 - 302	3000:5	C400	0.3	0.3	0.3	0.3	0.3	1.235	1.33	1.0
139 - 352	3500:5	C200	0.3	0.3	0.3	0.3	0.3	1.352	1.0	1.0
139 - 402	4000:5	C200	0.3	0.3	0.3	0.3	0.3	1.545	1.0	0.8
139 - 502	5000:5	C400	0.3	0.3	0.3	0.3	0.3	3.025	1.0	0.8

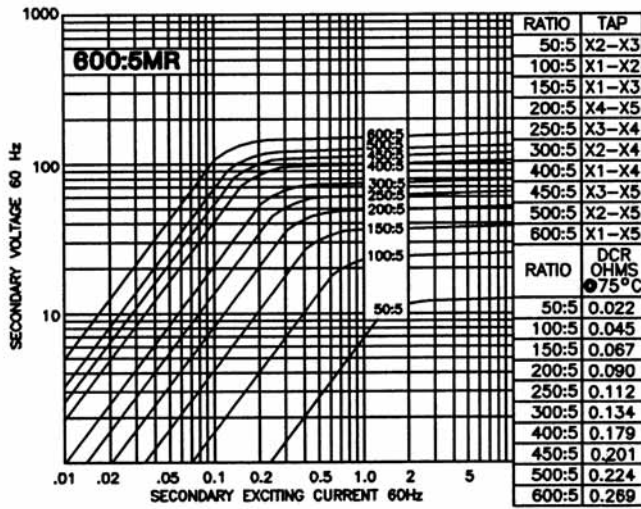

Model 139-601MR - rating C100
TRF= 2.0 @ 30°C, 2.0 @ 55°C amb.

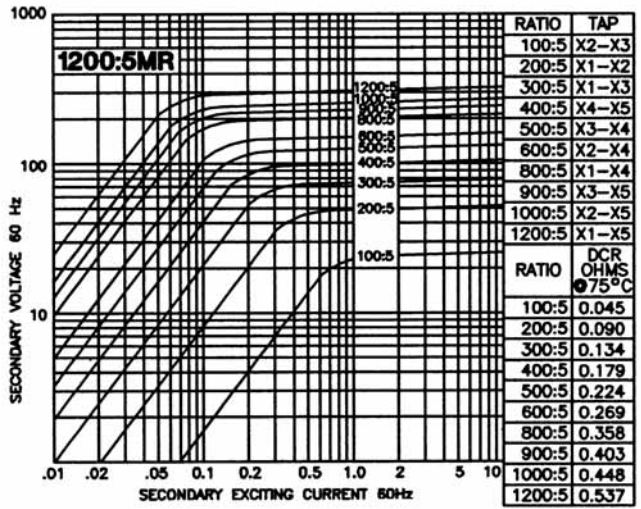

Model 139-122MR - rating C200
TRF= 1.5 @ 30°C, 1.33 @ 55°C amb.

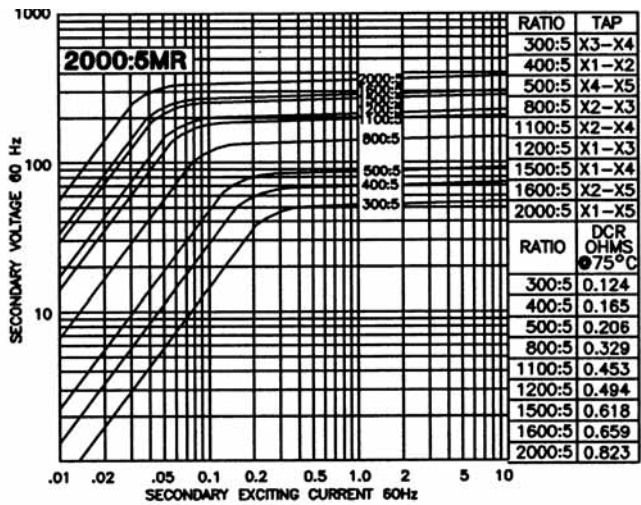

Model 139-202MR - rating C200
TRF= 1.5 @ 30°C, 1.33 @ 55°C amb.

Application:

Relaying and metering

Frequency:

50 - 400Hz

Insulation Level:

600 Volts, 10kV BIL full wave

- Terminals are brass studs No. 10 - 32 with one flatwasher, lockwasher and regular nut
- Multi ratios available upon request
- Order mounting bracket kit separately
- Approximately weight: 22 lbs

Approvals



Model 140

Window Diameter 8.13"

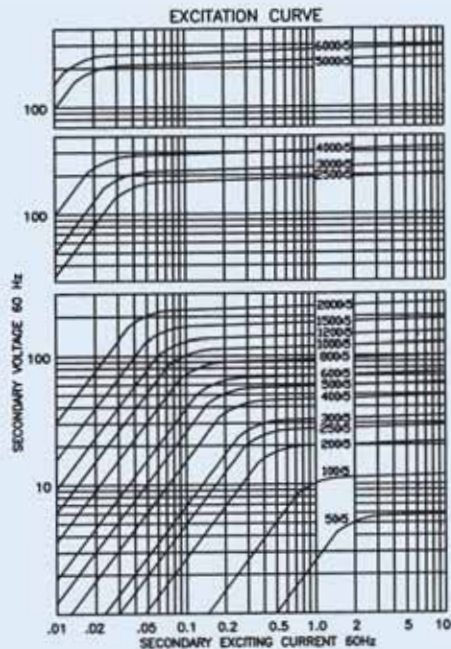
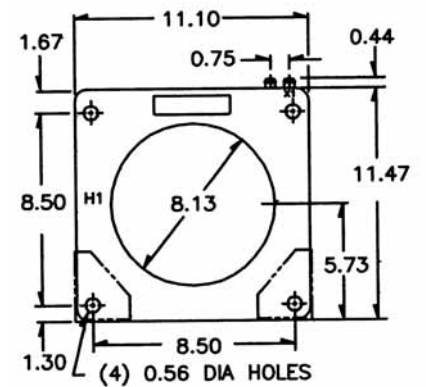
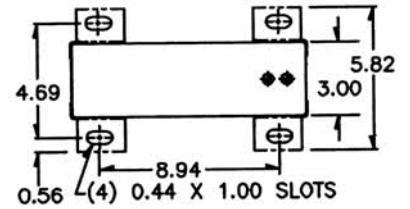
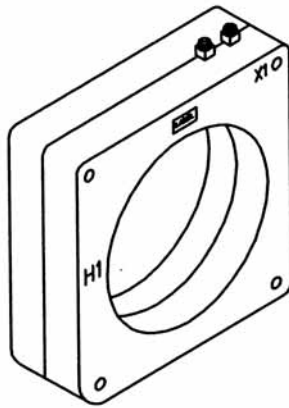

Catalogue Number	Current Ratio	Relay Class	ANSI metering class at 60Hz					Secondary winding resistance (OHMS @ 75°C)	Continuous thermal rating factor	
			B0.1	B0.2	B0.5	B0.9	B1.8		@30°C	@55°C
140 - 500	50:5	-	-	-	-	-	-	0.022	2.0	2.0
140 - 101	100:5	-	2.4	4.8	-	-	-	0.043	2.0	2.0
140 - 201	200:5	C10	1.2	1.2	2.4	4.8	-	0.088	2.0	2.0
140 - 251	250:5	C20	1.2	1.2	2.4	2.4	4.8	0.110	2.0	2.0
140 - 301	300:5	C20	0.6	1.2	1.2	2.4	2.4	0.131	2.0	2.0
140 - 401	400:5*	C20	0.3	0.3	0.6	1.2	2.4	0.150	2.0	2.0
140 - 501	500:5*	C20	0.3	0.3	0.6	1.2	1.2	0.216	2.0	2.0
140 - 601	600:5*	C50	0.3	0.3	0.3	0.6	1.2	0.276	2.0	2.0
140 - 801	800:5*	C50	0.3	0.3	0.3	0.3	0.6	0.351	2.0	2.0
140 - 102	1000:5*	C50	0.3	0.3	0.3	0.3	0.6	0.432	2.0	1.5
140 - 122	1200:5*	C100	0.3	0.3	0.3	0.3	0.3	0.529	1.5	1.5
140 - 152	1500:5*	C100	0.3	0.3	0.3	0.3	0.3	0.657	1.5	1.0
140 - 202	2000:5*	C100	0.3	0.3	0.3	0.3	0.3	0.865	1.33	1.0
140 - 252	2500:5*	C100	0.3	0.3	0.3	0.3	0.3	1.009	1.33	1.0
140 - 302	3000:5*	C100	0.3	0.3	0.3	0.3	0.3	1.211	1.0	0.8
140 - 402	4000:5*	C200	0.3	0.3	0.3	0.3	0.3	1.614	1.0	0.8
140 - 502	5000:5*	C50	0.3	0.3	0.3	0.3	0.3	1.836	1.0	0.8
140 - 602	6000:5E	C100	0.3	0.3	0.3	0.3	0.3	2.203	1.0	0.6

Model 140MR

Window Diameter 8.13"

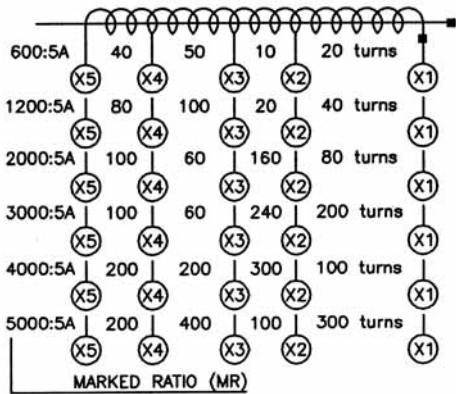
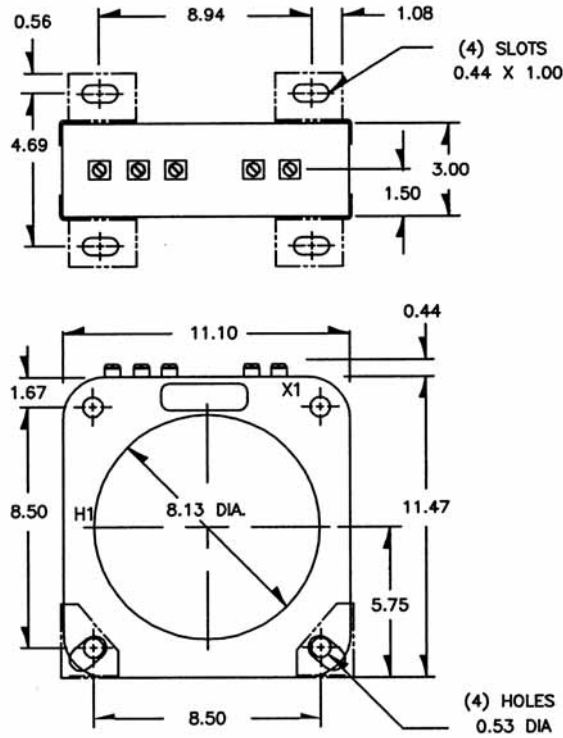
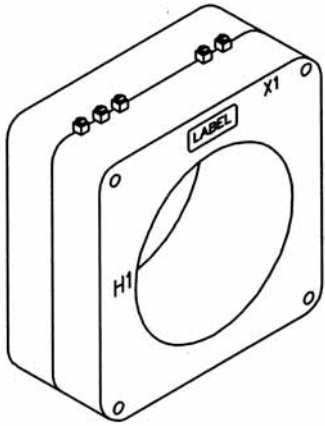

Application:
Relaying

Frequency:
50 - 400Hz

Insulation Level:
600 Volts, 10kV BIL full wave

Continuous Thermal Current Rating Factor:
See TRF at curve

- Terminals are brass studs No. 10 - 32 with one flat washer, lockwasher and regular nut
- The transformer winding is arranged so that the turns are fully distributed between all taps
- Order mounting bracket kit separately
- Approximate weight: 23 lbs

Approvals



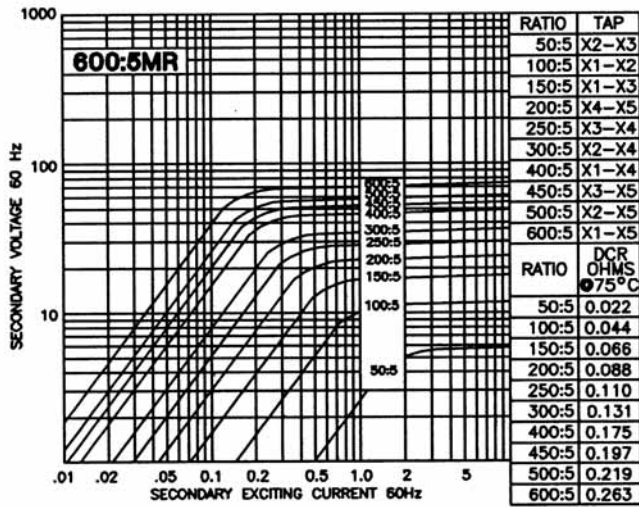

Model 140-60MR - rating C50

TRF= 2.0 ● 30°C, 2.0 ● 55°C amb.

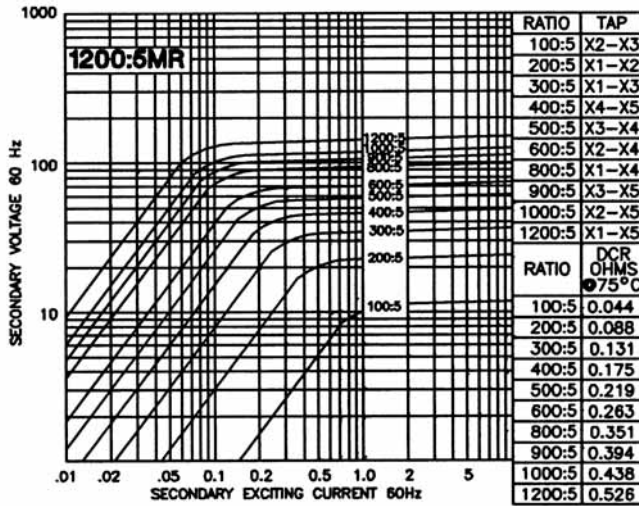

Model 140-122MR - rating C100

TRF= 1.5 ● 30°C, 1.5 ● 55°C amb.

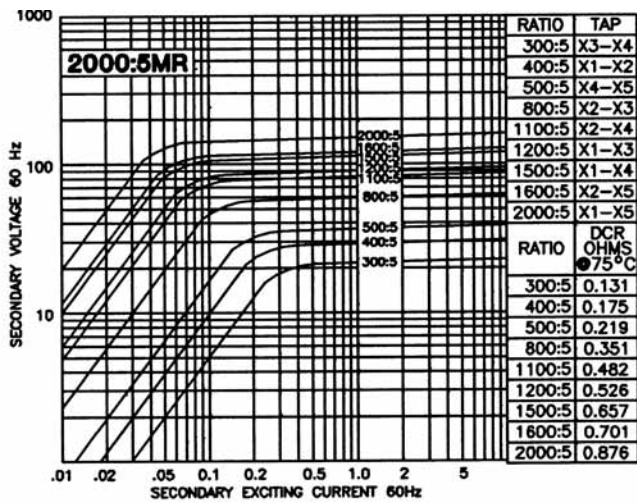

Model 140-202MR - rating C100

TRF= 1.33 ● 30°C, 1.0 ● 55°C amb.

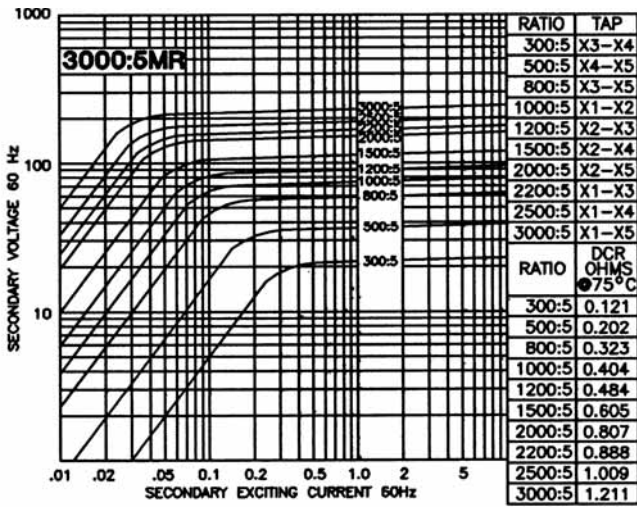

Model 140-302MR - rating C100
 TRF= 1.0 @ 30°C, 0.8 @ 55°C amb.

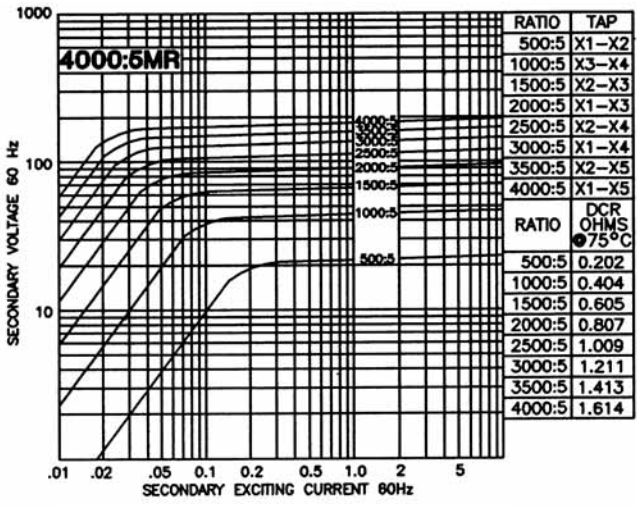

Model 140-402MR - rating C200
 TRF= 1.0 @ 30°C, 0.8 @ 55°C amb.

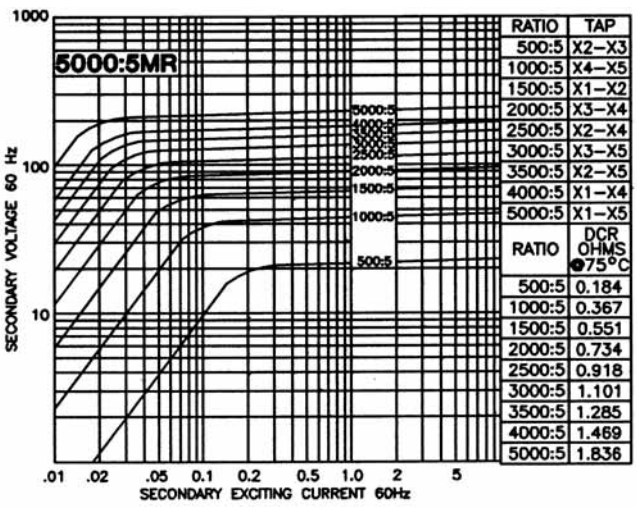

Model 140-502MR - rating C50
 TRF= 1.0 @ 30°C, 0.8 @ 55°C amb.

Application:

Relaying and metering

Frequency:

50 - 400Hz

Insulation Level:

600 Volts, 10kV BIL full wave

- Terminals are brass studs No. 10 - 32 with one flatwasher, lockwasher and regular nut
- Multi ratios available upon request
- Order mounting bracket kit separately
- Approximately weight: 44 lbs

Approvals



Model 141

Window Diameter 8.13"

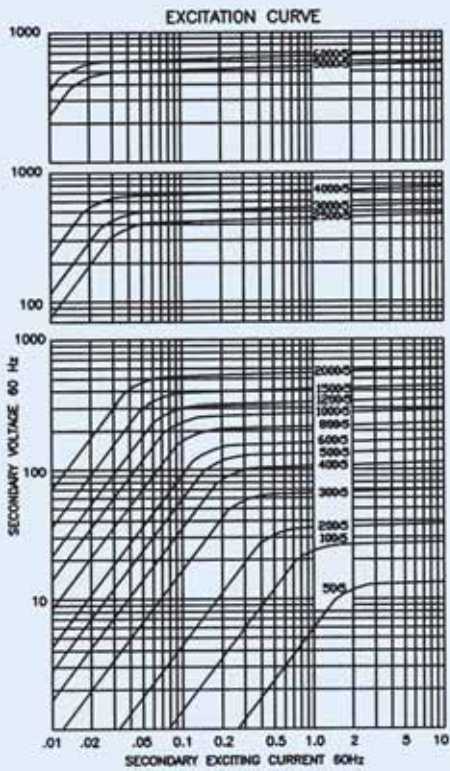
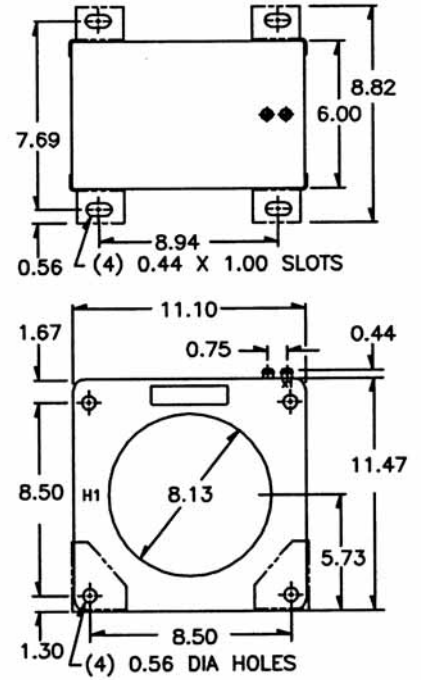
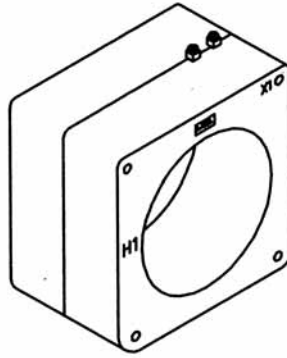

Catalogue Number	Current Ratio	Relay Class	ANSI metering class at 60Hz					Secondary winding resistance (OHMS @ 75 °C)	Continuous thermal rating factor	
			B0.1	B0.2	B0.5	B0.9	B1.8		@30 °C	@55 °C
141 - 500	50:5	C10	4.8	-	-	-	-	0.033	2.0	2.0
141 - 101	100:5	C10	2.4	2.4	-	-	-	0.066	2.0	2.0
141 - 201	200:5	C20	0.6	1.2	1.2	2.4	4.8	0.117	2.0	2.0
141 - 301	300:5	C50	0.6	0.6	1.2	1.2	2.4	0.248	2.0	2.0
141 - 401	400:5*	C50	0.3	0.3	0.6	0.6	1.2	0.277	2.0	2.0
141 - 501	500:5*	C100	0.3	0.3	0.3	0.6	0.6	0.415	2.0	2.0
141 - 601	600:5*	C100	0.3	0.3	0.3	0.3	0.6	0.498	2.0	1.5
141 - 801	800:5*	C100	0.3	0.3	0.3	0.3	0.3	0.664	2.0	1.5
141 - 102	1000:5*	C200	0.3	0.3	0.3	0.3	0.3	0.829	2.0	1.5
141 - 122	1200:5*	C200	0.3	0.3	0.3	0.3	0.3	1.002	2.0	1.5
141 - 152	1500:5*	C400	0.3	0.3	0.3	0.3	0.3	1.253	2.0	1.5
141 - 202	2000:5*	C400	0.3	0.3	0.3	0.3	0.3	1.659	1.33	1.0
141 - 252	2500:5*	C400	0.3	0.3	0.3	0.3	0.3	1.963	1.5	1.33
141 - 302	3000:5*	C400	0.3	0.3	0.3	0.3	0.3	2.356	1.5	1.0
141 - 402	4000:5*	C400	0.3	0.3	0.3	0.3	0.3	3.141	1.0	0.8
141 - 502	5000:5*	C200	0.3	0.3	0.3	0.3	0.3	2.862	1.0	0.8
141 - 602	6000:5*	C400	0.3	0.3	0.3	0.3	0.3	4.302	1.0	0.6

Model 141MR

Window Diameter 8.13"

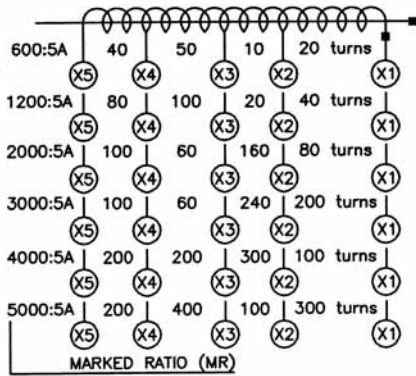
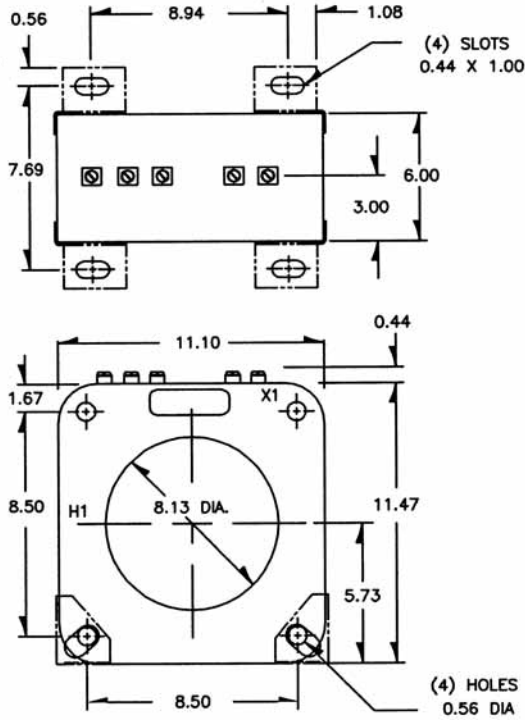
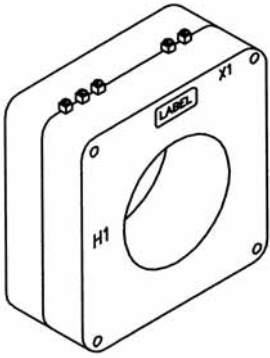

Application:
Relaying

Frequency:
50 - 400Hz:

Insulation Level:
600 Volts, 10kV BIL full wave

Continuous Thermal Current Rating Factor:
See TRF at curve

- Terminals are brass studs No. 10 - 32 with one flat washer, lockwasher and regular nut
- The transformer winding is arranged so that the turns are fully distributed between all taps
- Order mounting bracket kit separately
- Approximate weight: 45 lbs

Approvals



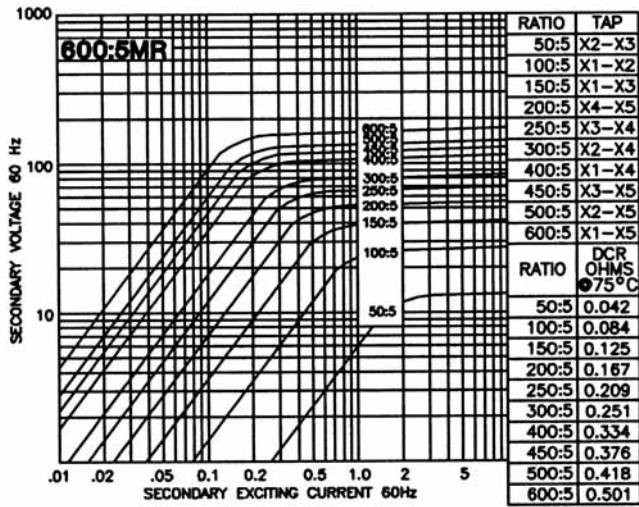

Model 141-60MR - rating C100
TRF= 2.0 ● 30°C, 1.5 ● 55°C amb.

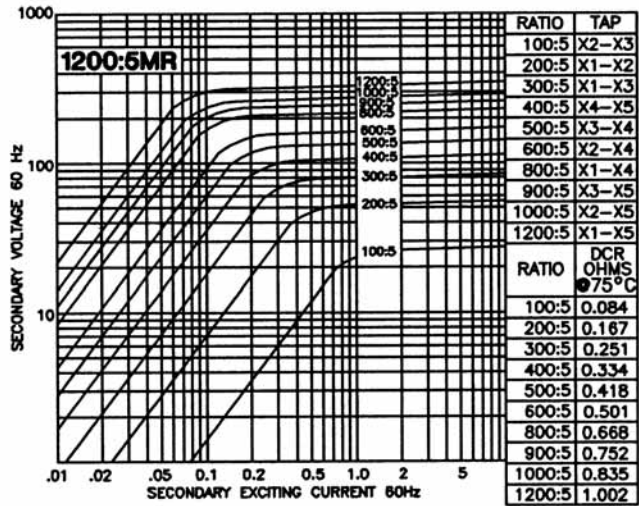

Model 141-122MR - rating C200
TRF= 2.0 ● 30°C, 1.5 ● 55°C amb.

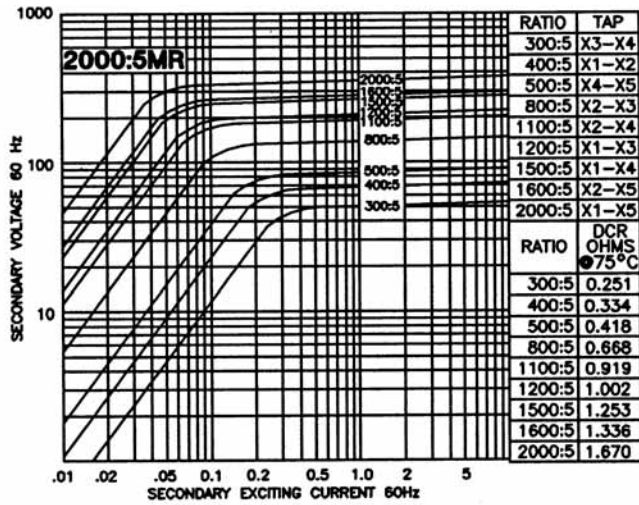

Model 140-202MR - rating C400
TRF= 1.33 ● 30°C, 1.0 ● 55°C amb.

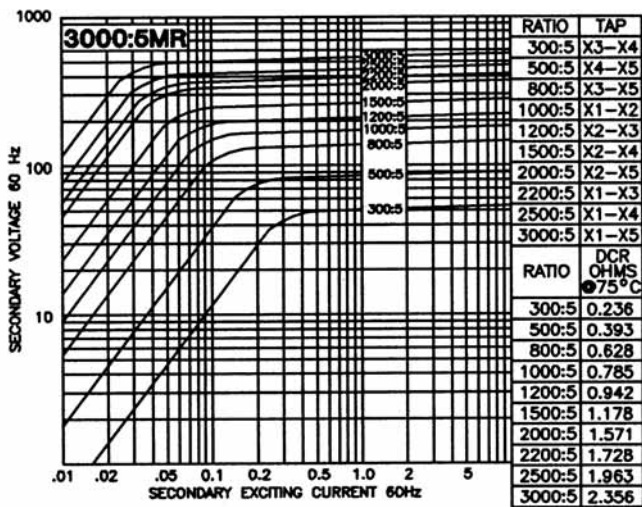

Model 141-302MR - rating C400
TRF= 1.5 @ 30°C, 1.33 @ 55°C amb.

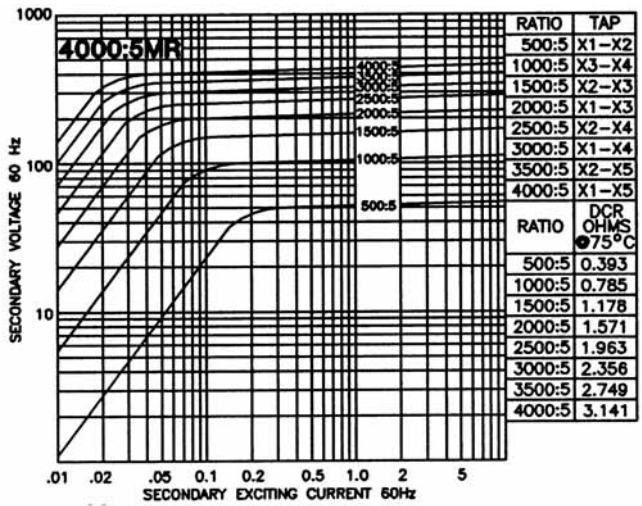

Model 140-402MR - rating C400
TRF= 1.0 @ 30°C, 0.8 @ 55°C amb.

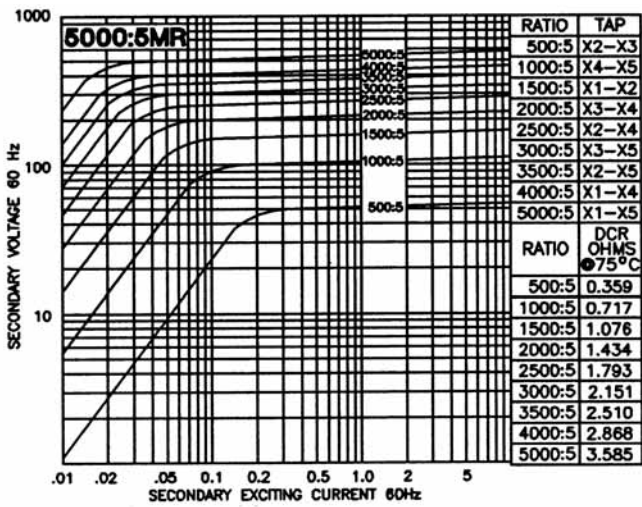

Model 141-502MR - rating C200
TRF= 1.0 @ 30°C, 0.8 @ 55°C amb.

Application:

Relaying and metering

Frequency:

50 - 400Hz:

Insulation Level:

600 Volts, 10kV BIL full wave

- Terminals are brass studs No. 10 - 32 with one flatwasher, lockwasher and regular nut
- Multi ratios available upon request
- Order mounting bracket kit separately
- Approximately weight: 31 lbs

Approvals



Model 142

Window Diameter 7.25"

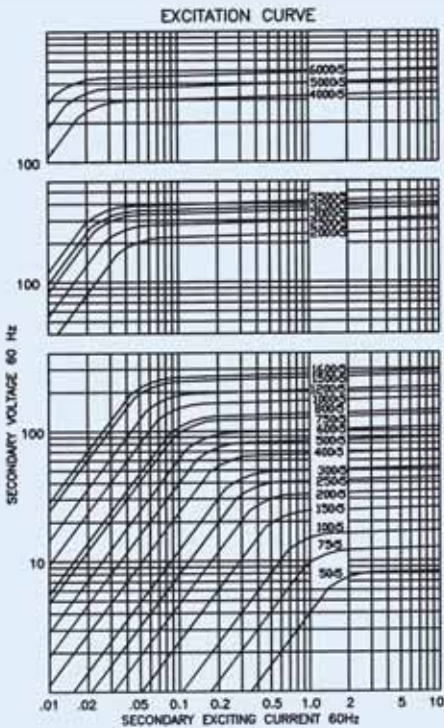
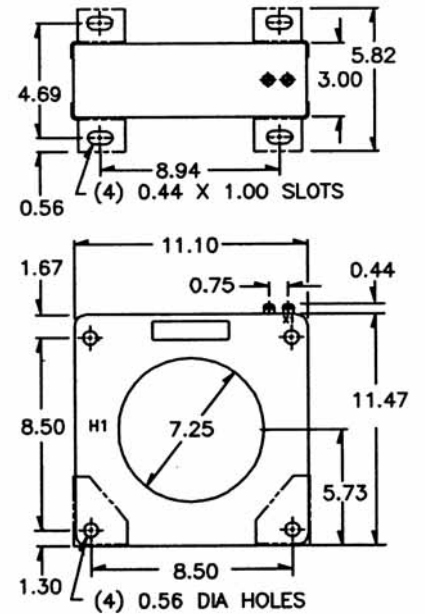
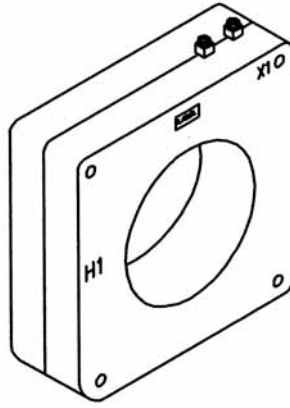

Catalogue Number	Current Ratio	Relay Class	ANSI metering class at 60Hz					Secondary winding resistance (OHMS @ 75 °C)	Continuous thermal rating factor	
			B0.1	B0.2	B0.5	B0.9	B1.8		@30 °C	@55 °C
142 - 500	50:5	-	-	-	-	-	-	0.031	2.0	2.0
142 - 750	75:5	-	2.4	4.8	-	-	-	0.035	2.0	2.0
142 - 101	100:5	C10	1.2	2.4	4.8	-	-	0.051	2.0	2.0
142 - 151	150:5	C10	1.2	1.2	2.4	4.8	-	0.070	2.0	2.0
142 - 201	200:5*	C20	0.6	0.6	1.2	2.4	4.8	0.102	2.0	2.0
142 - 251	250:5*	C20	0.6	0.6	1.2	1.2	2.4	0.127	2.0	2.0
142 - 301	300:5*	C30	0.3	0.3	0.6	1.2	2.4	0.153	2.0	2.0
142 - 401	400:5*	C50	0.3	0.3	0.3	0.6	1.2	0.196	2.0	2.0
142 - 501	500:5*	C50	0.3	0.3	0.3	0.6	0.6	0.252	2.0	2.0
142 - 601	600:5*	C50	0.3	0.3	0.3	0.3	0.6	0.255	2.0	2.0
142 - 751	750:5*	C100	0.3	0.3	0.3	0.3	0.3	0.304	2.0	1.5
142 - 801	800:5*	C100	0.3	0.3	0.3	0.3	0.3	0.336	2.0	1.5
142 - 102	1000:5*	C100	0.3	0.3	0.3	0.3	0.3	0.486	2.0	1.5
142 - 122	1200:5*	C100	0.3	0.3	0.3	0.3	0.3	0.735	1.5	1.0
142 - 152	1500:5*	C200	0.3	0.3	0.3	0.3	0.3	0.918	1.5	1.0
142 - 162	1600:5*	C200	0.3	0.3	0.3	0.3	0.3	0.979	1.33	1.0
142 - 202	2000:5*	C200	0.3	0.3	0.3	0.3	0.3	0.544	2.0	1.5
142 - 252	2500:5*	C200	0.3	0.3	0.3	0.3	0.3	1.066	1.5	1.0
142 - 302	3000:5*	C200	0.3	0.3	0.3	0.3	0.3	1.280	1.0	0.8
142 - 322	3200:5*	C200	0.3	0.3	0.3	0.3	0.3	1.365	1.0	0.8
142 - 352	3500:5*	C200	0.3	0.3	0.3	0.3	0.3	1.493	1.0	0.8
142 - 402	4000:5*	C200	0.3	0.3	0.3	0.3	0.3	1.452	1.0	0.8
142 - 502	5000:5*	C200	0.3	0.3	0.3	0.3	0.3	1.915	1.0	0.8
142 - 602	6000:5*	C200	0.3	0.3	0.3	0.3	0.3	2.298	1.0	0.6

Model 142MR

Window Diameter 7.25"

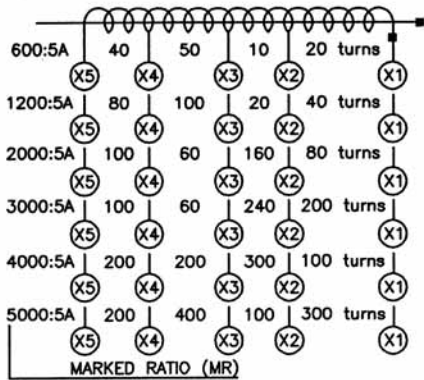
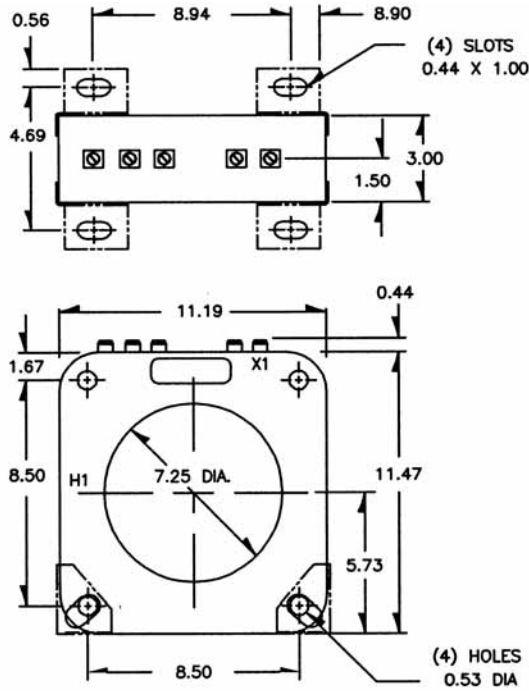
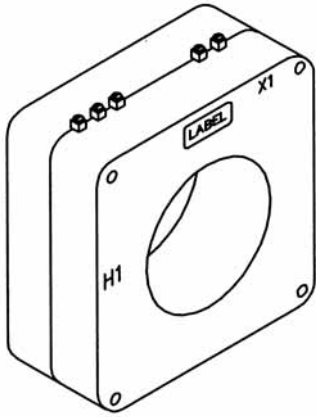

Application:
Relaying

Frequency:
50 - 400Hz

Insulation Level:
600 Volts, 10kV BIL full wave

Continuous Thermal Current Rating Factor:
See TRF at curve

- Terminals are brass studs No. 10 - 32 with one flat washer, lockwasher and regular nut
- The transformer winding is arranged so that the turns are fully distributed between all taps
- Order mounting bracket kit separately
- Approximate weight: 31 lbs

Approvals



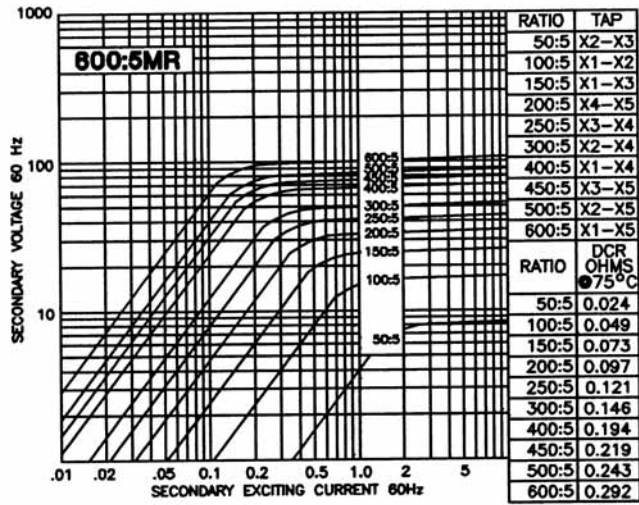

Model 142-601MR - rating C50
 TRF= 2.0 ● 30°C, 2.0 ● 55°C amb.

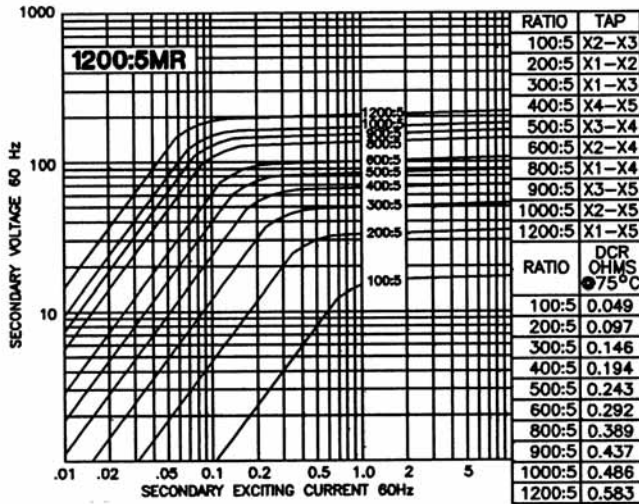

Model 142-122MR - rating C100
 TRF= 1.5 ● 30°C, 1.0 ● 55°C amb.

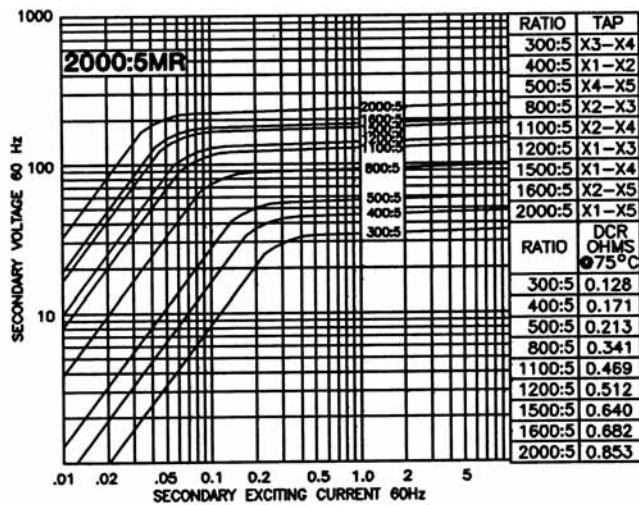

Model 142-202MR - rating C200
 TRF= 2.0 ● 30°C, 1.5 ● 55°C amb.

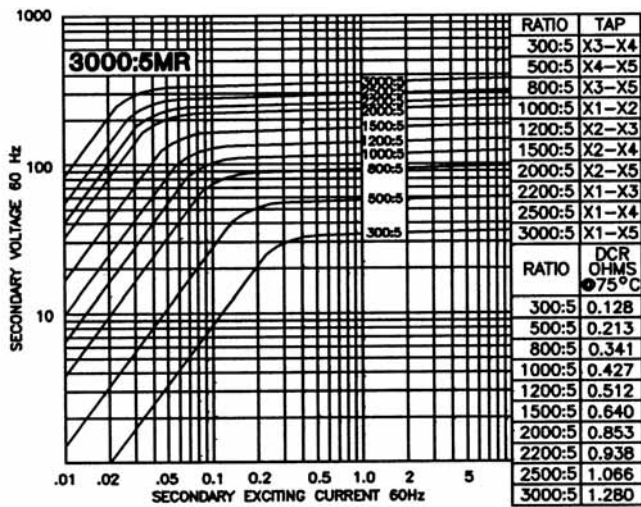

Model 142-302MR - rating C200
TRF= 1.0 @ 30°C, 0.8 @ 55°C amb.

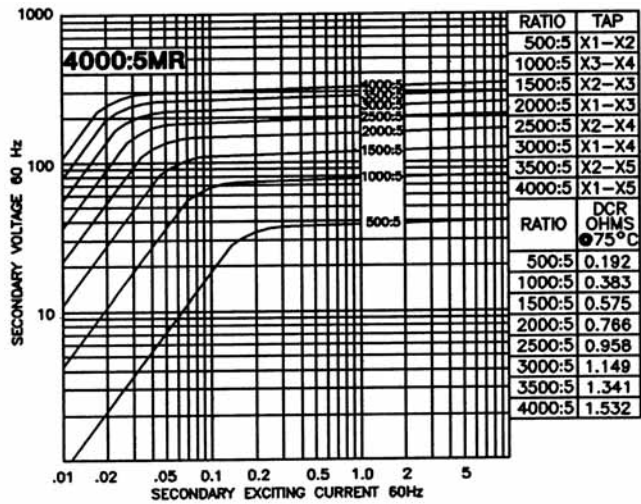

Model 142-402MR - rating C200
TRF= 1.0 @ 30°C, 0.8 @ 55°C amb.

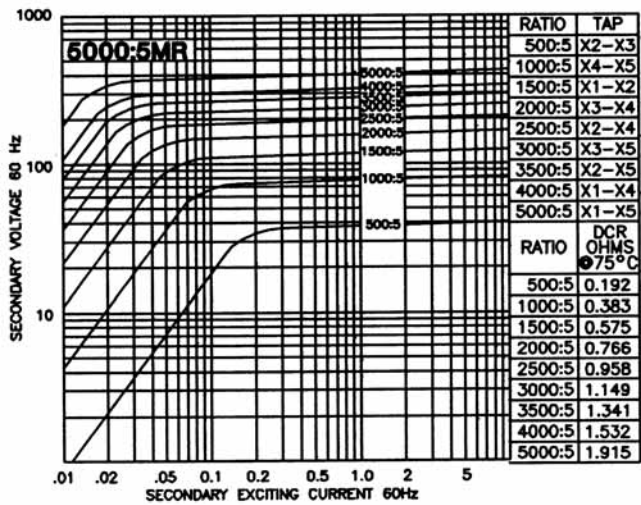

Model 140-502MR - rating C200
TRF= 1.0 @ 30°C, 0.8 @ 55°C amb.

Application:

Relaying and metering

Frequency:

50 - 400Hz

Insulation Level:

600 Volts, 10kV BIL full wave

- Terminals are brass studs No. 10 - 32 with one flatwasher, lockwasher and regular nut
- Multi ratios available upon request
- Order mounting bracket kit separately
- Approximately weight: 60 lbs

Approvals



Model 143

Window Diameter 7.31"

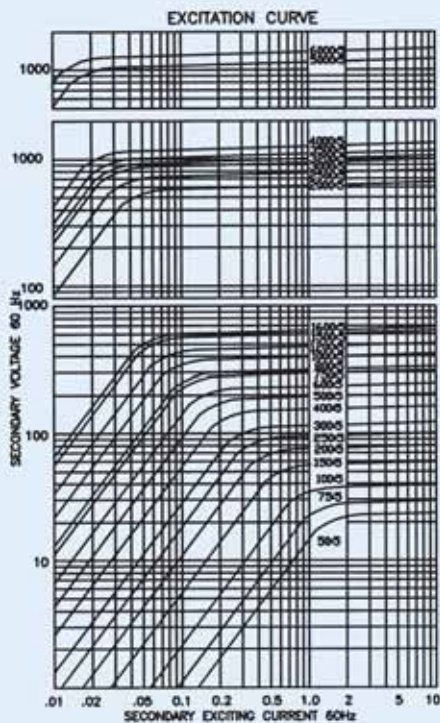
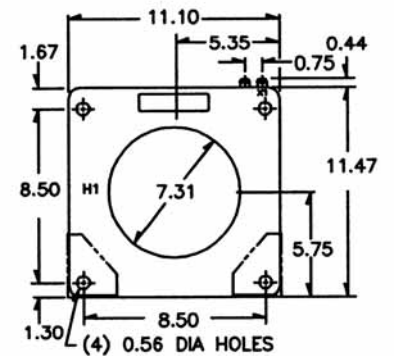
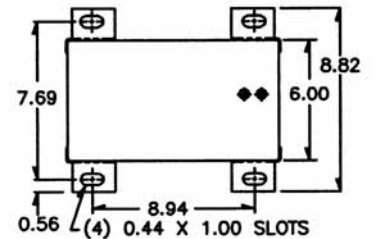
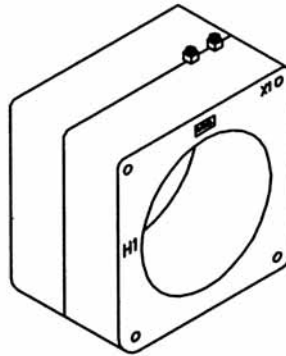

Catalogue Number	Current Ratio	Relay Class	ANSI metering class at 60Hz					Secondary winding resistance (OHMS @ 75 °C)	Continuous thermal rating factor	
			B0.1	B0.2	B0.5	B0.9	B1.8		@30 °C	@55 °C
143 - 500	50:5	C20	4.8	4.8	-	-	-	0.014	2.0	2.0
143 - 750	75:5	C20	2.4	2.4	-	-	-	0.042	2.0	2.0
143 - 101	100:5	C20	1.2	2.4	4.8	4.8	-	0.056	2.0	2.0
143 - 151	150:5*	C20	0.6	0.6	1.2	2.4	4.8	0.121	2.0	2.0
143 - 201	200:5*	C50	0.3	0.3	0.6	1.2	2.4	0.161	2.0	2.0
143 - 251	250:5*	C50	0.3	0.3	0.6	1.2	2.4	0.175	2.0	2.0
143 - 301	300:5*	C100	0.3	0.3	0.3	0.6	1.2	0.241	2.0	2.0
143 - 401	400:5*	C100	0.3	0.3	0.3	0.3	0.6	0.322	2.0	2.0
143 - 501	500:5*	C100	0.3	0.3	0.3	0.3	0.6	0.441	2.0	2.0
143 - 601	600:5*	C200	0.3	0.3	0.3	0.3	0.3	0.530	2.0	1.5
143 - 751	750:5*	C200	0.3	0.3	0.3	0.3	0.3	0.662	2.0	1.5
143 - 801	800:5*	C200	0.3	0.3	0.3	0.3	0.3	0.706	2.0	1.5
143 - 102	1000:5*	C200	0.3	0.3	0.3	0.3	0.3	0.883	1.5	1.33
143 - 122	1200:5*	C400	0.3	0.3	0.3	0.3	0.3	1.059	1.5	1.0
143 - 152	1500:5*	C400	0.3	0.3	0.3	0.3	0.3	1.324	1.5	1.0
143 - 162	1600:5*	C400	0.3	0.3	0.3	0.3	0.3	1.413	1.33	1.0
143 - 202	2000:5*	C400	0.3	0.3	0.3	0.3	0.3	1.678	1.33	1.0
143 - 252	2500:5*	C400	0.3	0.3	0.3	0.3	0.3	2.097	1.0	0.8
143 - 302	3000:5*	C800	0.3	0.3	0.3	0.3	0.3	2.516	1.0	0.8
143 - 322	3200:5*	C800	0.3	0.3	0.3	0.3	0.3	2.684	1.0	0.8
143 - 352	3500:5*	C800	0.3	0.3	0.3	0.3	0.3	2.936	1.0	0.8
143 - 402	4000:5*	C800	0.3	0.3	0.3	0.3	0.3	3.355	1.0	0.6
143 - 502	5000:5*	C800	0.3	0.3	0.3	0.3	0.3	3.983	1.0	0.6
143 - 602	6000:5*	C800	0.3	0.3	0.3	0.3	0.3	4.780	0.8	0.6

Model 143MR

Window Diameter 7.13"

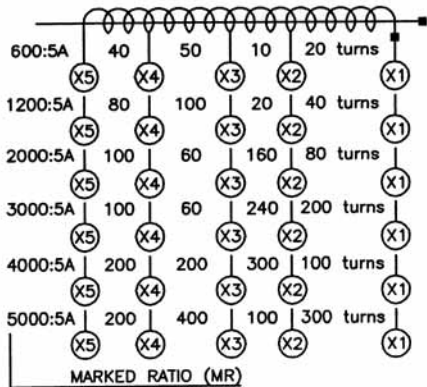
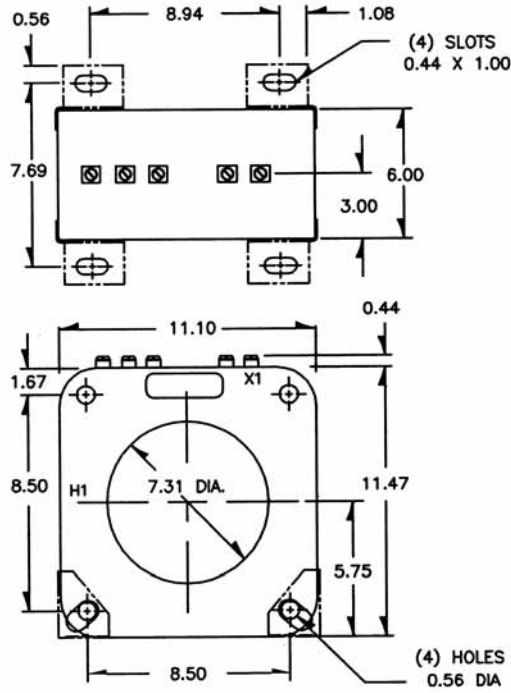
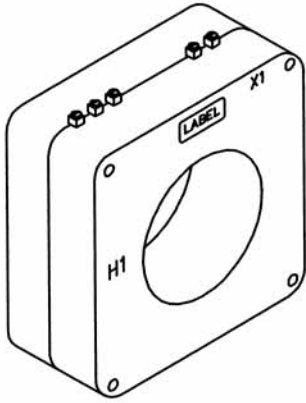

Application:
Relaying

Frequency:
50 - 400Hz:

Insulation Level:
600 Volts, 10kV BIL full wave

Continuous Thermal Current Rating Factor:
See TRF at curve

- Terminals are brass studs No. 10 - 32 with one flat washer, lockwasher and regular nut
- The transformer winding is arranged so that the turns are fully distributed between all taps
- Order mounting bracket kit separately
- Approximate weight: 60 lbs

Approvals



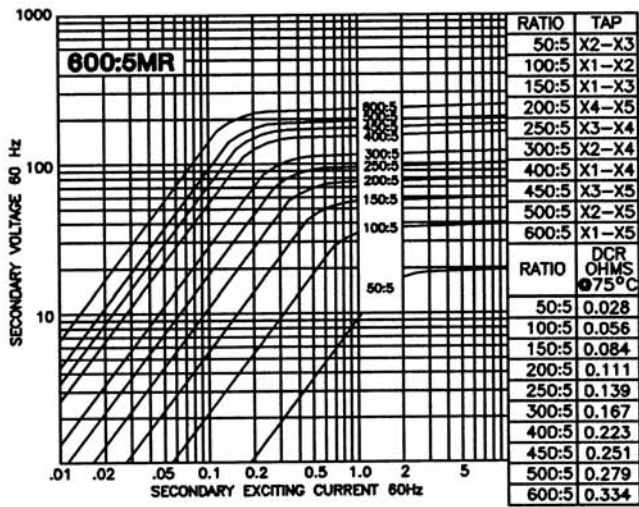

Model 143-601MR - rating C200
 TRF= 2.0 ● 30°C, 1.5 ● 55°C amb.

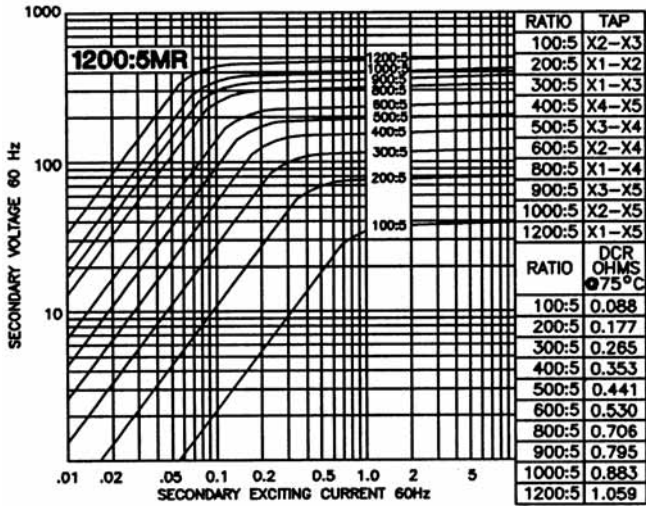

Model 143-122MR - rating C400
 TRF= 1.5 ● 30°C, 1.0 ● 55°C amb.

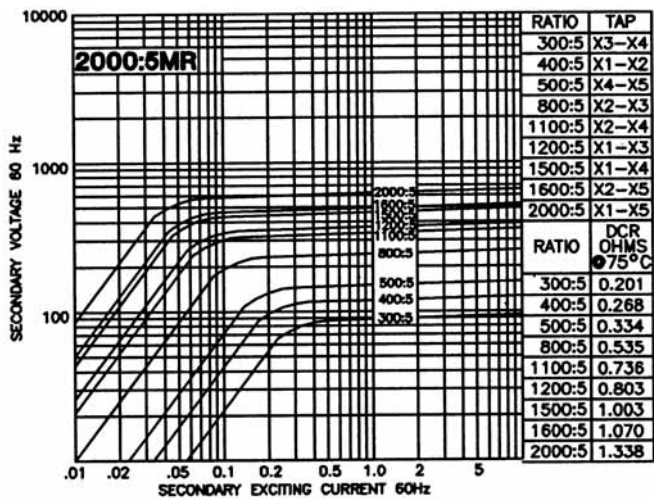

Model 143-202MR - rating C400
 TRF= 1.33 ● 30°C, 1.0 ● 55°C amb.

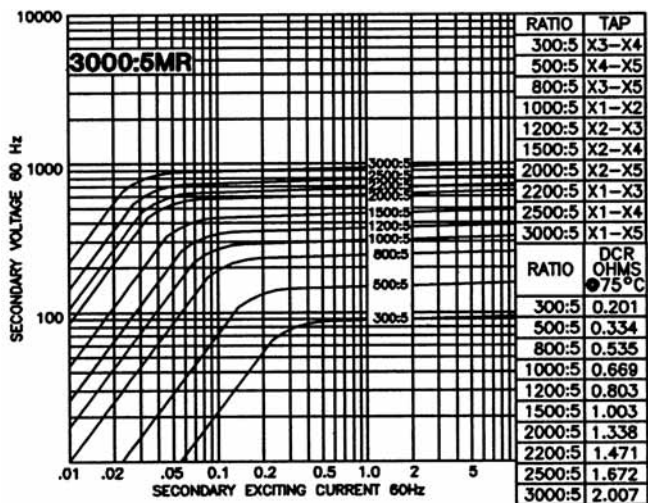

Model 143-302MR - rating C800

TRF= 1.0 @ 30°C, 0.8 @ 55°C amb.

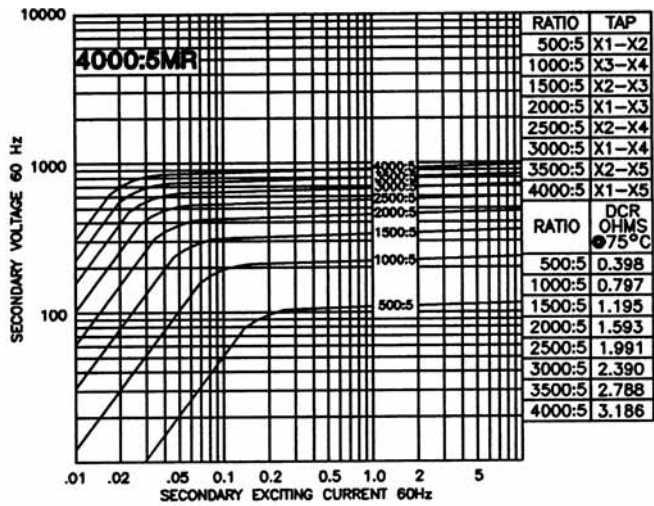

Model 143-402MR - rating C800

TRF= 1.0 @ 30°C, 0.6 @ 55°C amb.

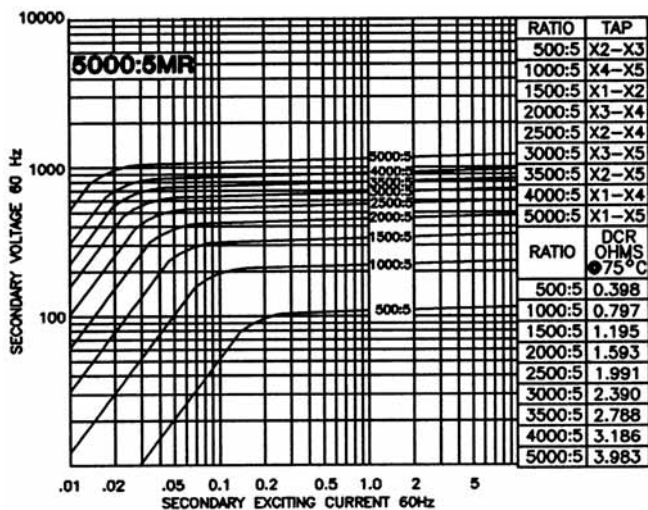

Model 143-502MR - rating C800

TRF= 1.0 @ 30°C, 0.6 @ 55°C amb.

Application:

Relaying and metering

Frequency:

50 - 400Hz:

Insulation Level:

600 Volts, 10kV BIL full wave

- Terminals are brass studs No. 10 - 32 with one flatwasher, lockwasher and regular nut
- Multi ratios available upon request
- Order mounting bracket kit separately
- Approximately weight: 40 lbs

Approvals



Model 144

Window Diameter 6.0"

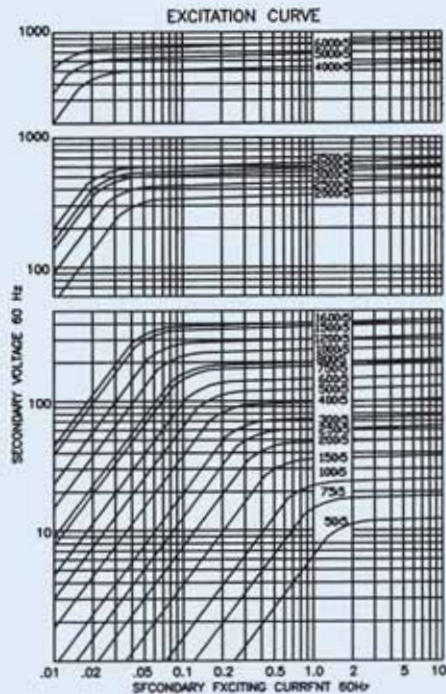
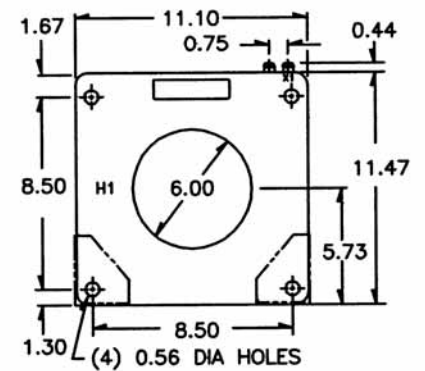
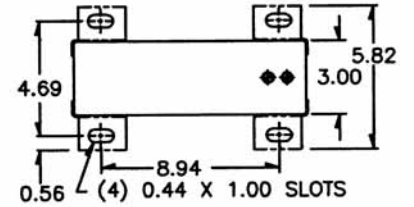
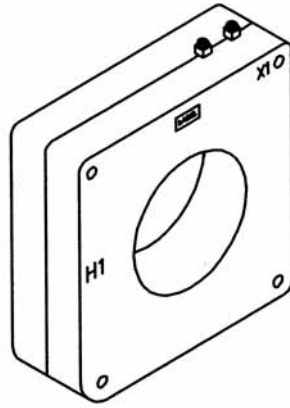

Catalogue Number	Current Ratio	Relay Class	ANSI metering class at 60Hz					Secondary winding resistance (OHMS @ 75 °C)	Continuous thermal rating factor	
			B0.1	B0.2	B0.5	B0.9	B1.8		@30 °C	@55 °C
144 - 500	50:5	-	2.4	4.8	-	-	-	0.020	2.0	2.0
144 - 750	75:5	C10	1.2	2.4	-	-	-	0.032	2.0	2.0
144 - 101	100:5	C10	1.2	1.2	2.4	4.8	-	0.040	2.0	2.0
144 - 151	150:5*	C20	0.6	0.6	1.2	2.4	4.8	0.057	2.0	2.0
144 - 201	200:5*	C20	0.6	0.6	1.2	2.4	2.4	0.067	2.0	2.0
144 - 251	250:5*	C50	0.3	0.3	0.6	1.2	2.4	0.125	2.0	2.0
144 - 301	300:5*	C50	0.3	0.3	0.6	0.6	1.2	0.150	2.0	2.0
144 - 401	400:5*	C50	0.3	0.3	0.3	0.6	0.6	0.195	2.0	2.0
144 - 501	500:5*	C100	0.3	0.3	0.3	0.6	0.6	0.282	2.0	2.0
144 - 601	600:5*	C100	0.3	0.3	0.3	0.3	0.6	0.338	2.0	1.5
144 - 751	750:5*	C100	0.3	0.3	0.3	0.3	0.3	0.213	2.0	2.0
144 - 801	800:5*	C100	0.3	0.3	0.3	0.3	0.3	0.451	2.0	1.5
144 - 102	1000:5*	C200	0.3	0.3	0.3	0.3	0.3	0.563	2.0	1.5
144 - 122	1200:5*	C200	0.3	0.3	0.3	0.3	0.3	0.676	1.5	1.33
144 - 152	1500:5*	C200	0.3	0.3	0.3	0.3	0.3	0.845	1.5	1.0
144 - 162	1600:5*	C200	0.3	0.3	0.3	0.3	0.3	0.902	1.5	1.0
144 - 202	2000:5*	C200	0.3	0.3	0.3	0.3	0.3	1.002	1.5	1.0
144 - 252	2500:5*	C400	0.3	0.3	0.3	0.3	0.3	1.252	1.33	1.0
144 - 302	3000:5*	C400	0.3	0.3	0.3	0.3	0.3	1.503	1.0	0.8
144 - 322	3200:5*	C400	0.3	0.3	0.3	0.3	0.3	1.603	1.0	0.8
144 - 352	3500:5*	C200	0.3	0.3	0.3	0.3	0.3	1.592	1.0	0.8
144 - 402	4000:5*	C400	0.3	0.3	0.3	0.3	0.3	1.820	1.0	0.8
144 - 502	5000:5*	C400	0.3	0.3	0.3	0.3	0.3	2.275	1.0	0.6
144 - 602	6000:5*	C400	0.3	0.3	0.3	0.3	0.3	2.730	0.8	0.6

Model 144MR

Window Diameter 6.0"

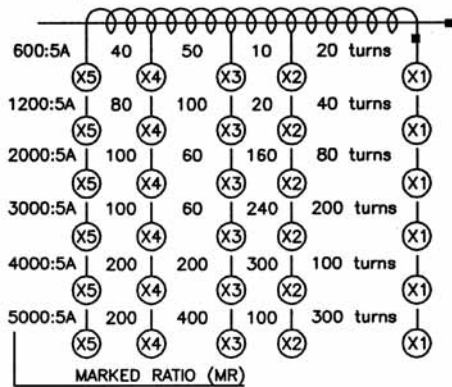
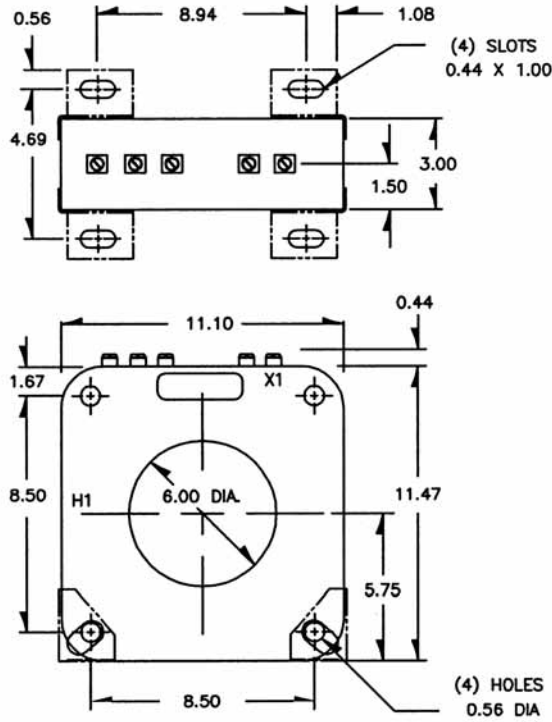
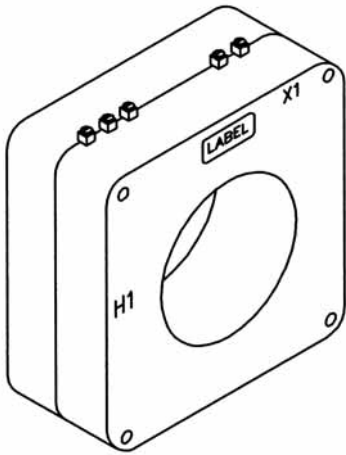

Application:
Relaying

Frequency:
50 - 400Hz

Insulation Level:
600 Volts, 10kV BIL full wave

- Continuous Thermal Current Rating Factor:**
See TRF at curve
- Terminals are brass studs No. 10 - 32 with one flat washer, lockwasher and regular nut
 - The transformer winding is arranged so that the turns are fully distributed between all taps
 - Order mounting bracket kit separately
 - Approximate weight: 40 lbs

Approvals



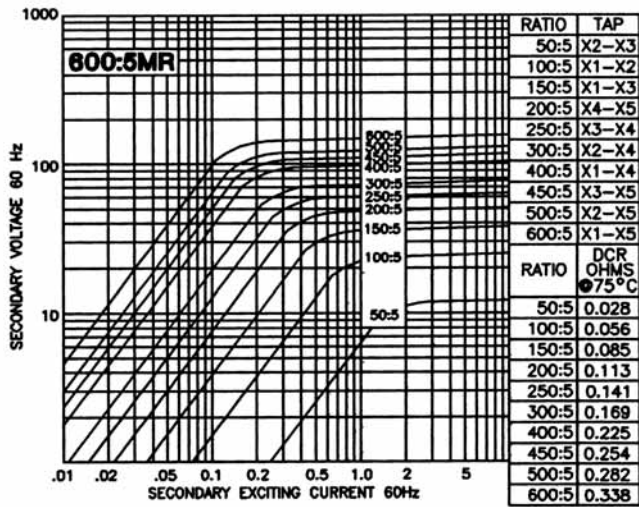

Model 144-601MR - rating C100

TRF= 2.0 @ 30°C, 1.5 @ 55°C amb.

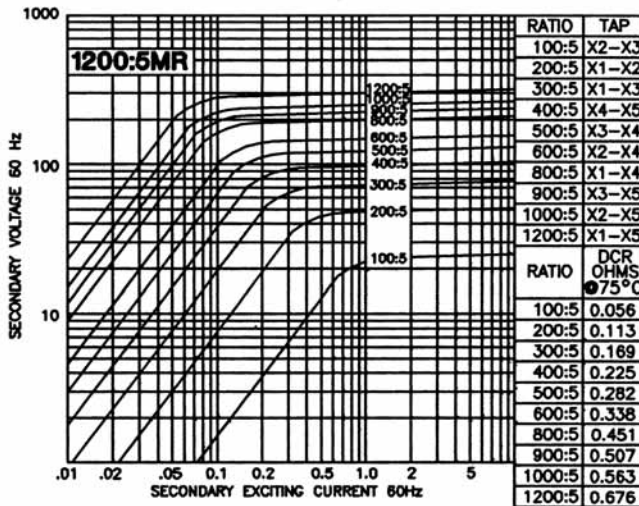

Model 144-122MR - rating C200

TRF= 2.0 @ 30°C, 1.5 @ 55°C amb.

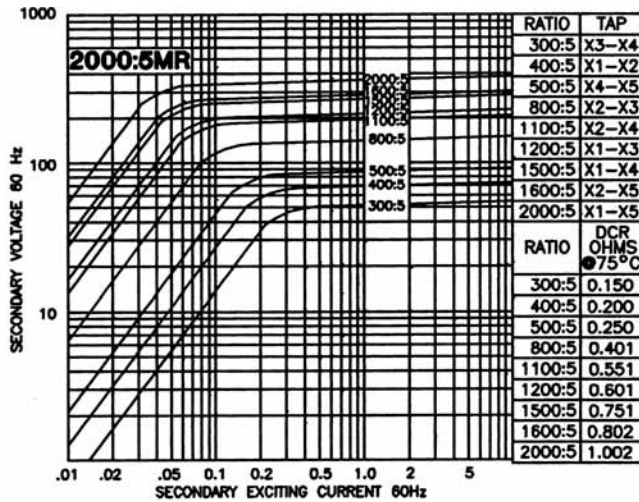

Model 144-202MR - rating C200

TRF= 1.5 @ 30°C, 1.0 @ 55°C amb.

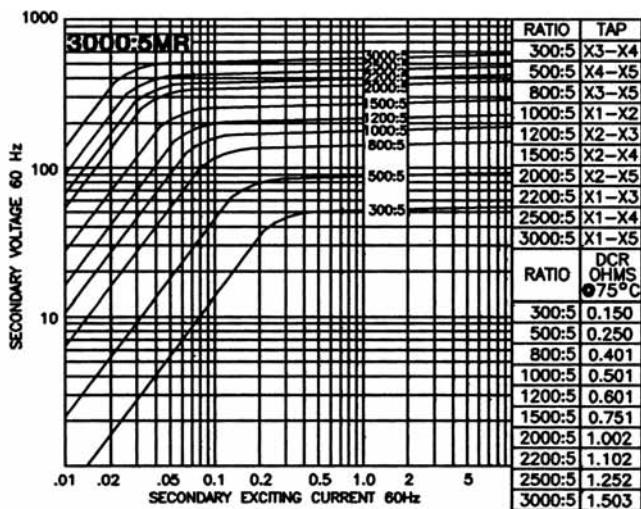

Model 144-302MR - rating C400
TRF= 1.0 @ 30°C, 0.8 @ 55°C amb.

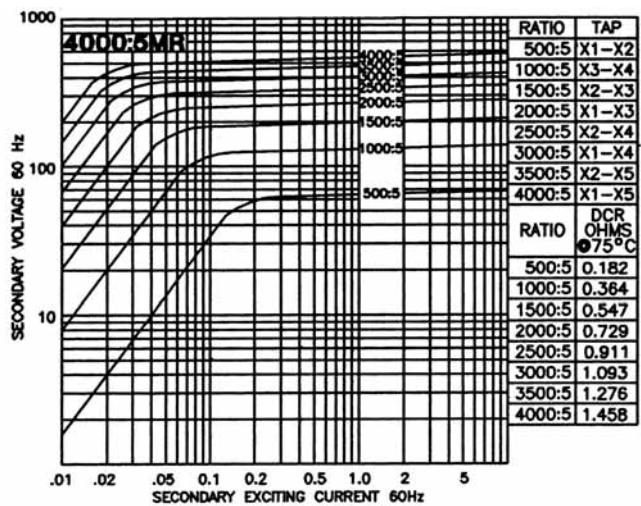

Model 144-402MR - rating C400
TRF= 1.0 @ 30°C, 0.8 @ 55°C amb.

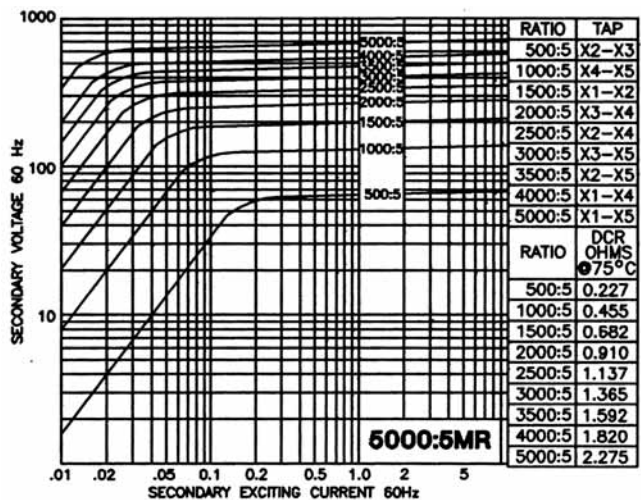

Model 144-502MR - rating C400
TRF= 1.0 @ 30°C, 0.6 @ 55°C amb.

Application:

Relaying and metering

Frequency:

50 - 400Hz

Insulation Level:

600 Volts, 10kV BIL full wave

- Terminals are brass studs No. 10 - 32 with one flatwasher, lockwasher and regular nut
- Multi ratios available upon request
- Order mounting bracket kit separately
- Approximately weight: 83 lbs

Approvals



Model 145

Window Diameter 6.0"

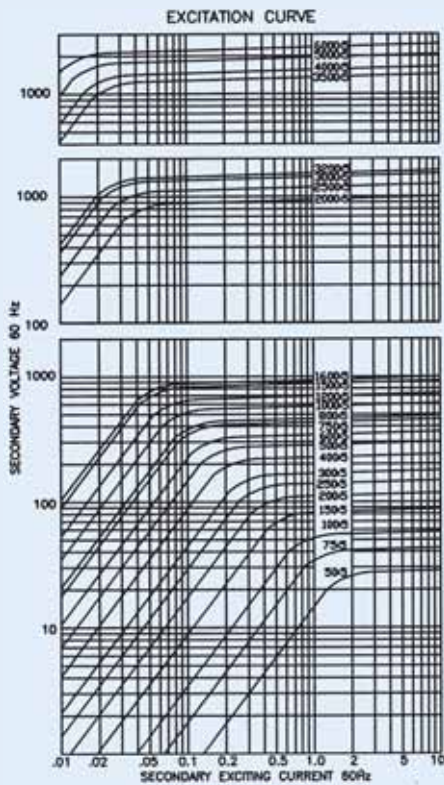
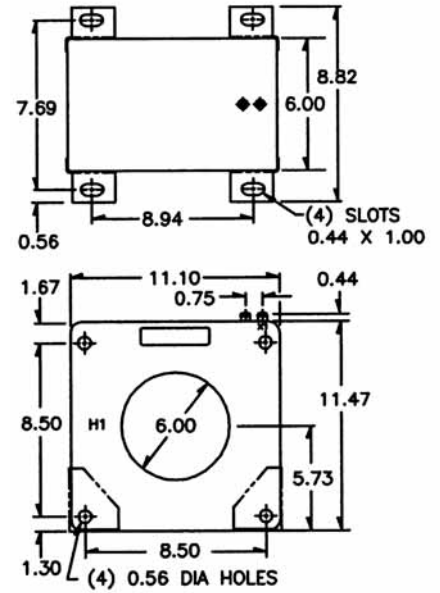
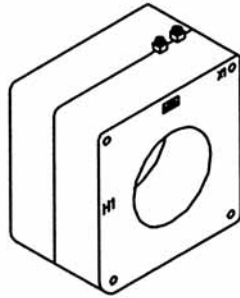

Catalogue Number	Current Ratio	Relay Class	ANSI metering class at 60Hz					Secondary winding resistance (OHMS @ 75°C)	Continuous thermal rating factor	
			B0.1	B0.2	B0.5	B0.9	B1.8		@30°C	@55°C
145 - 500	50:5	C20	1.2	4.8	-	-	-	0.030	2.0	2.0
145 - 750	75:5	C20	1.2	2.4	4.8	4.8	-	0.045	2.0	2.0
145 - 101	100:5	C20	0.6	1.2	2.4	4.8	4.8	0.061	2.0	2.0
145 - 151	150:5	C50	0.6	0.6	1.2	2.4	2.4	0.091	2.0	2.0
145 - 201	200:5*	C100	0.3	0.6	0.6	1.2	2.4	0.121	2.0	2.0
145 - 251	250:5*	C100	0.3	0.3	0.6	0.6	1.2	0.152	2.0	2.0
145 - 301	300:5*	C100	0.3	0.3	0.3	0.6	1.2	0.288	2.0	2.0
145 - 401	400:5*	C200	0.3	0.3	0.3	0.3	0.6	0.384	2.0	2.0
145 - 501	500:5*	C200	0.3	0.3	0.3	0.3	0.3	0.480	2.0	1.5
145 - 601	600:5*	C200	0.3	0.3	0.3	0.3	0.3	0.576	2.0	1.5
145 - 751	750:5*	C400	0.3	0.3	0.3	0.3	0.3	0.720	2.0	1.5
145 - 801	800:5*	C400	0.3	0.3	0.3	0.3	0.3	0.768	2.0	1.5
145 - 102	1000:5*	C400	0.3	0.3	0.3	0.3	0.3	0.960	1.5	1.33
145 - 122	1200:5*	C400	0.3	0.3	0.3	0.3	0.3	1.153	1.5	1.0
145 - 152	1500:5*	C800	0.3	0.3	0.3	0.3	0.3	1.441	1.5	1.0
145 - 162	1600:5*	C800	0.3	0.3	0.3	0.3	0.3	1.537	1.33	1.0
145 - 202	2000:5*	C800	0.3	0.3	0.3	0.3	0.3	1.829	1.33	1.0
145 - 252	2500:5*	C800	0.3	0.3	0.3	0.3	0.3	2.286	1.0	0.8
14v - 302	3000:5*	C800	0.3	0.3	0.3	0.3	0.3	2.743	1.0	0.8
145 - 322	3200:5*	C800	0.3	0.3	0.3	0.3	0.3	2.926	1.0	0.8
145 - 352	3500:5*	C800	0.3	0.3	0.3	0.3	0.3	3.040	1.0	0.8
145 - 402	4000:5*	C800	0.3	0.3	0.3	0.3	0.3	3.474	1.0	0.6
145 - 502	5000:5*	C800	0.3	0.3	0.3	0.3	0.3	4.342	0.8	0.6
145 - 602	6000:5*	C800	0.3	0.3	0.3	0.3	0.3	5.211	0.8	0.6

Model 145MR

Window Diameter 6.00"

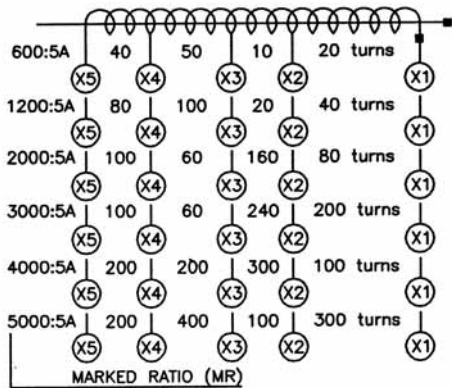
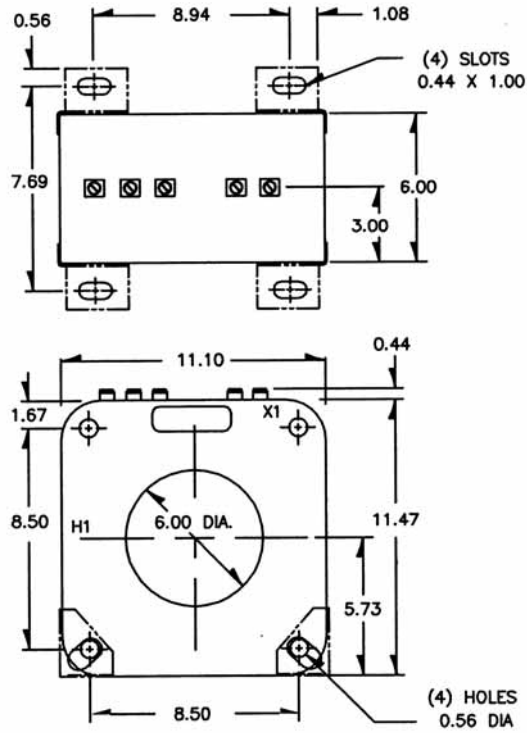
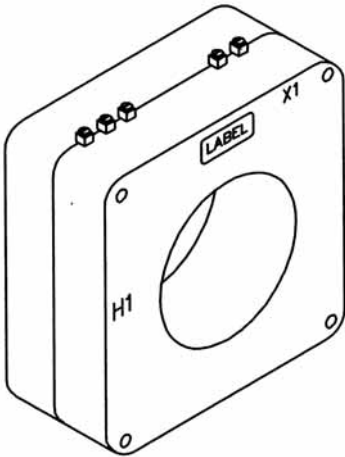

Application:
Relaying

Frequency:
50 - 400Hz:

Insulation Level:
600 Volts, 10kV BIL full wave

Continuous Thermal Current Rating Factor:
See TRF at curve

- Terminals are brass studs No. 10 - 32 with one flat washer, lockwasher and regular nut
- The transformer winding is arranged so that the turns are fully distributed between all taps
- Order mounting bracket kit separately
- Approximate weight: 85 lbs

Approvals



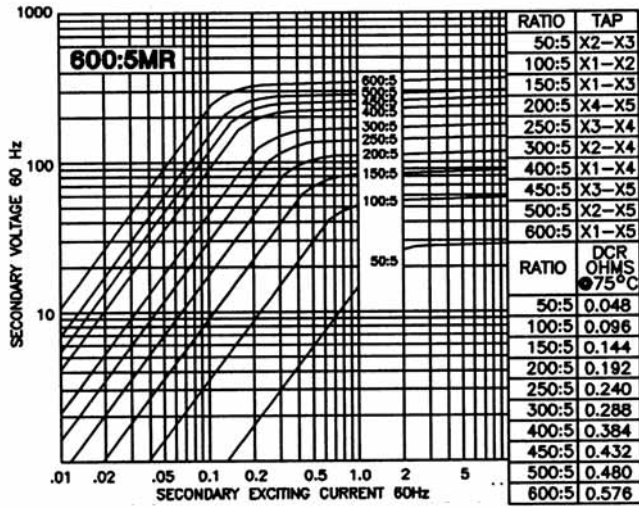

Model 145-601MR - rating C200
TRF= 2.0 @ 30°C, 1.5 @ 55°C amb.

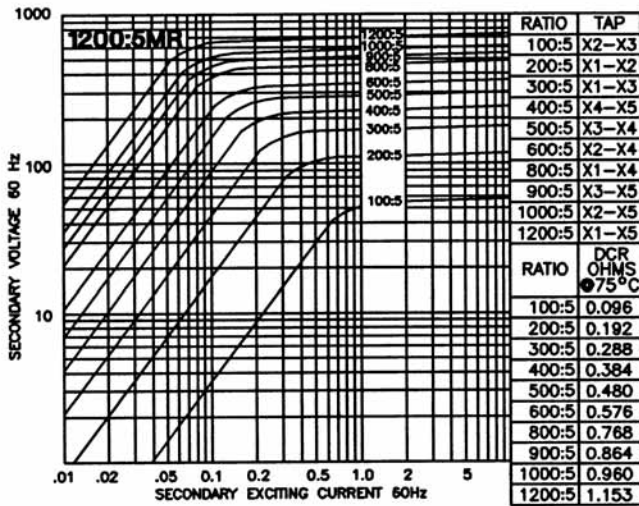

Model 145-122MR - rating C400
TRF= 1.5 @ 30°C, 1.0 @ 55°C amb.

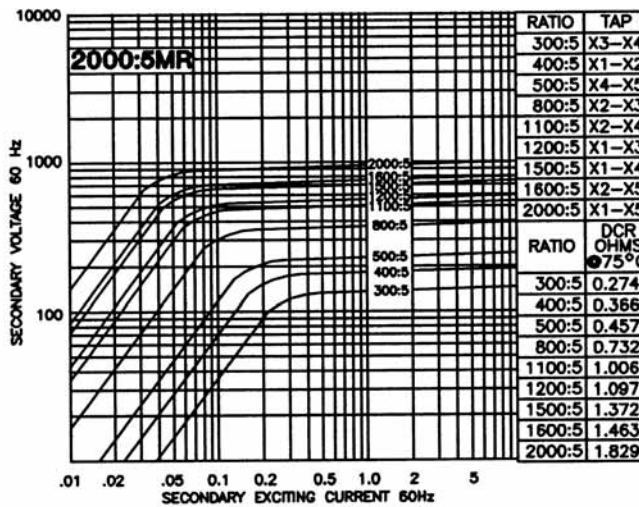

Model 145-202MR - rating C800
TRF= 1.33 @ 30°C, 1.0 @ 55°C amb.

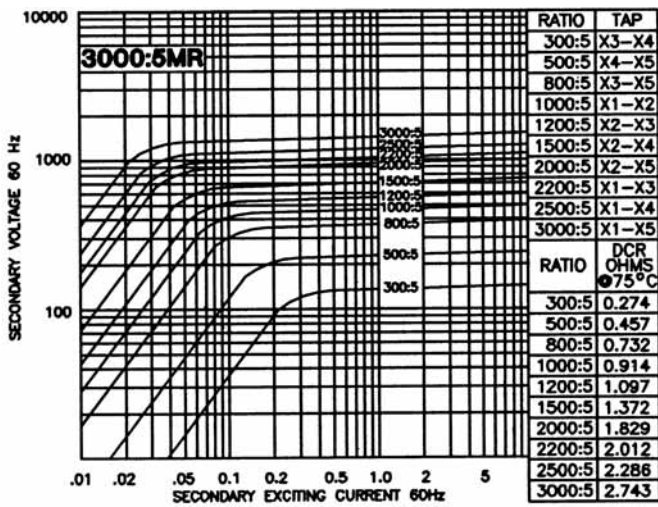

Model 145-302MR - rating C800
TRF= 1.0 @ 30°C, 0.8 @ 55°C amb.

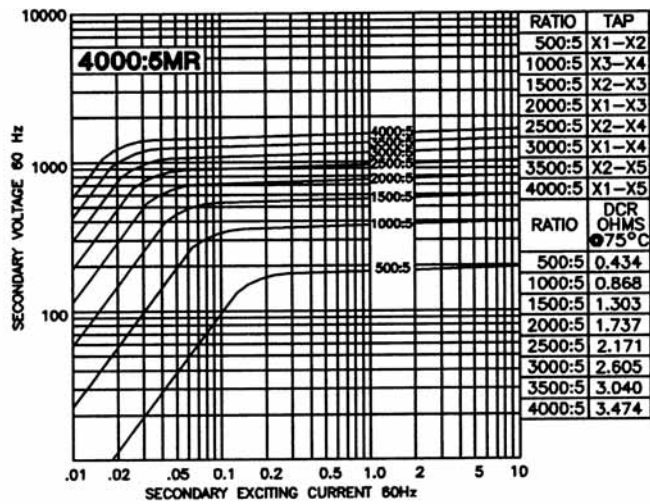

Model 145-402MR - rating C800
TRF= 1.0 @ 30°C, 0.6 @ 55°C amb.

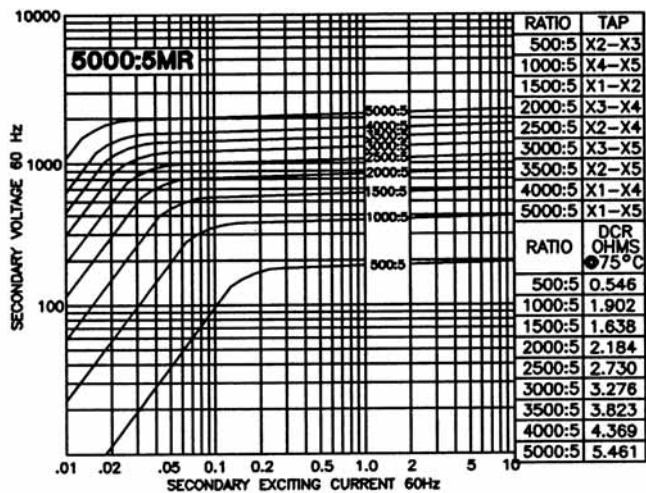

Model 145-502MR - rating C800
TRF= 0.8 @ 30°C, 0.6 @ 55°C amb.

Application:
Metering

Frequency:
50 - 400Hz:

Insulation Level:

600 Volts, 10kV BIL full wave

- Terminals are brass studs No. 8 - 32 with one flatwasher, lockwasher and regular nut
- Flexible leads are UL 1015 105°C, CSA approved. #16AWG, 24" long
- Non-standard lead length can be specified
- Order mounting bracket kit separately
- Model 170SHT also available as 170SHL with leads
- Approximate weight: 3 lbs

Model 170

Window Diameter 4.25"

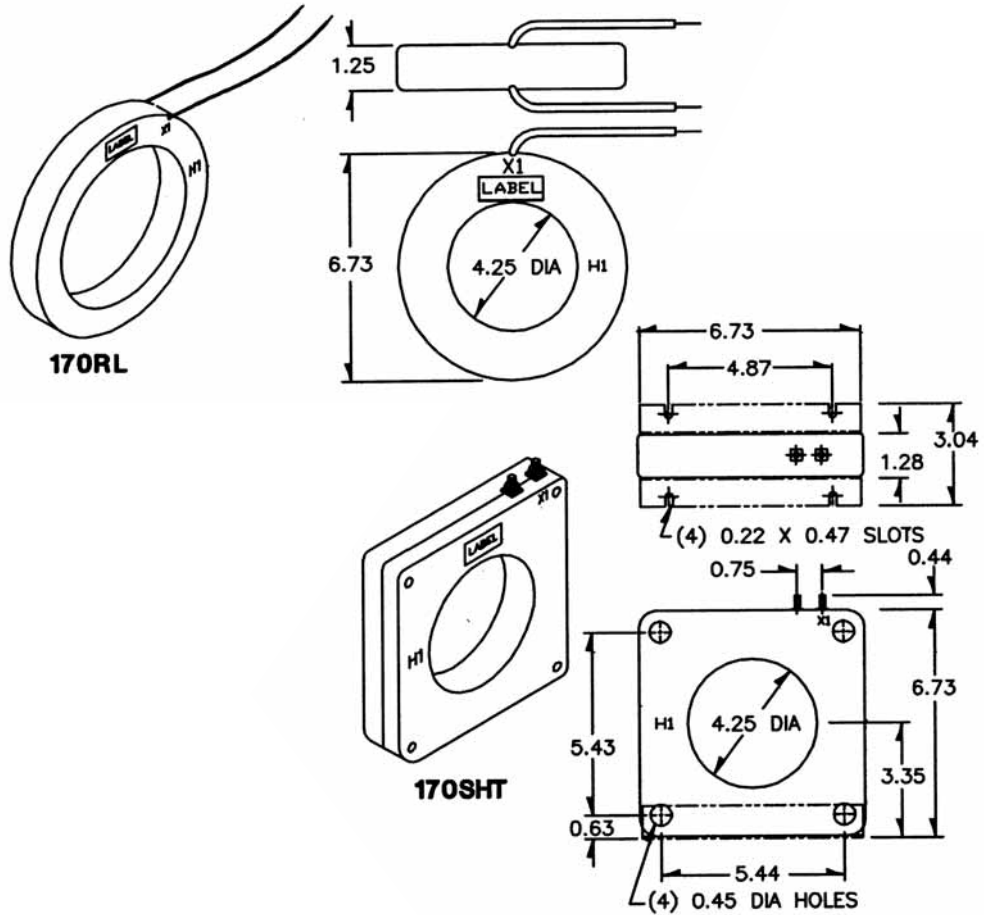

Approvals

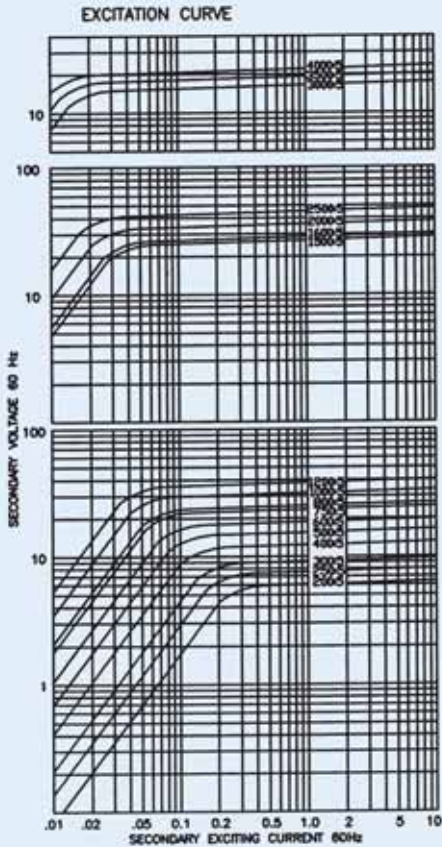

Catalogue Number	Current Ratio	V.A. for ±1% Class	ANSI metering class at 60Hz					Secondary winding resistance (OHMS @ 75 °C)	Continuous thermal rating factor	
			B0.1	B0.2	B0.5	B0.9	B1.8		@30 °C	@55 °C
170** - 201	200:5	5.0	0.6	1.2	2.4	-	-	0.040	2.0	2.0
170** - 251	250:5	5.0	0.6	0.6	1.2	2.4	-	0.047	2.0	2.0
170** - 301	300:5	12.5	0.6	0.6	1.2	2.4	-	0.053	2.0	2.0
170** - 401	400:5	25.0	0.3	0.3	0.6	1.2	2.4	0.080	2.0	2.0
170** - 501	500:5	25.0	0.3	0.3	0.6	1.2	1.2	0.110	2.0	1.5
170** - 601	600:5	25.0	0.3	0.3	0.6	0.6	1.2	0.121	2.0	1.5
170** - 751	750:5	40.0	0.3	0.3	0.3	0.3	0.6	0.151	2.0	1.5
170** - 801	800:5	50.0	0.3	0.3	0.3	0.3	0.6	0.162	2.0	1.5
170** - 102	1000:5	75.0	0.3	0.3	0.3	0.3	0.6	0.265	1.33	1.0
170** - 122	1200:5	100.0	0.3	0.3	0.3	0.3	0.6	0.318	1.33	1.0
170** - 152	1500:5	80.0	0.3	0.3	0.3	0.3	0.6	0.344	1.33	1.0
170** - 162	1600:5	90.0	0.3	0.3	0.3	0.3	0.6	0.367	1.33	1.0
170** - 202	2000:5	100.0	0.3	0.3	0.3	0.3	0.3	0.459	1.0	0.8
170** - 252	2500:5	130.0	0.3	0.3	0.3	0.3	0.3	0.573	1.0	0.8
170** - 302	3000:5	160.0	0.3	0.3	0.3	0.3	0.3	0.424	1.0	1.0
170** - 352	3500:5	190.0	0.3	0.3	0.3	0.3	0.3	0.495	1.0	0.8
170** - 402	4000:5	200.0	0.3	0.3	0.3	0.3	0.3	0.646	1.0	0.8

Models 191, 192, 193, 194, 195

Window Diameters 1.25", 1.75", 2.13", 2.5", 3.06"

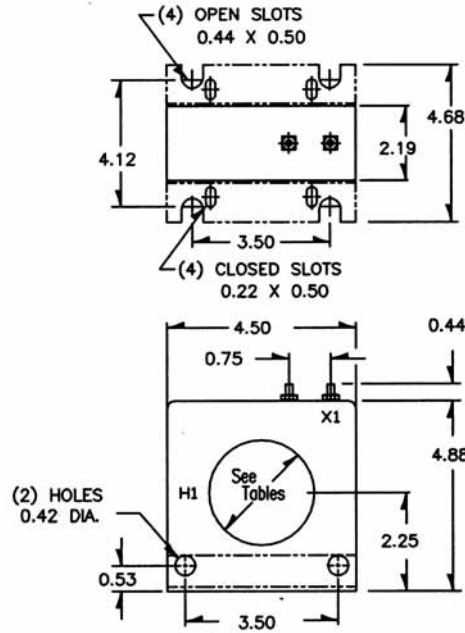
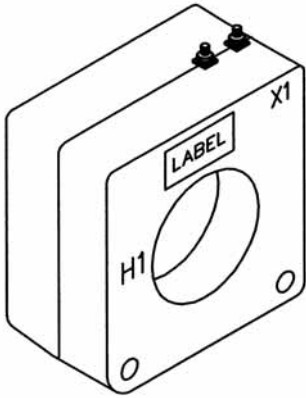

Model 191

Window Diameter 1.25"

• Approximate weight: 5.5 lbs

Catalogue Number	Current Ratio	Relay Class	ANSI metering class at 60Hz					Secondary winding resistance (OHMS @ 75 °C)	Continuous thermal rating factor	
			B0.1	B0.2	B0.5	B0.9	B1.8		@30 °C	@55 °C
191 - 101	100:5	-	0.6	0.6	2.4	4.8	-	0.034	2.0	2.0
191 - 151	150:5	C10	0.3	0.3	1.2	1.2	2.4	0.051	2.0	2.0
191 - 201	200:5	C10	0.3	0.3	0.6	1.2	2.4	0.068	2.0	2.0
191 - 251	250:5	C20	0.3	0.3	0.3	0.6	1.2	0.085	2.0	1.5
191 - 301	300:5	C20	0.3	0.3	0.3	0.3	0.6	0.126	1.5	1.33
191 - 401	400:5	C20	0.3	0.3	0.3	0.3	0.6	0.189	1.5	1.0

Application:
Metering

Frequency:
50 - 400Hz

Insulation Level:

600 Volts, 10kV BIL full wave

- Terminals are brass studs No. 8 - 32 with one flatwasher, lockwasher and regular nut
- Order mounting bracket kit separately
- Multi-ratios available upon request

Approvals

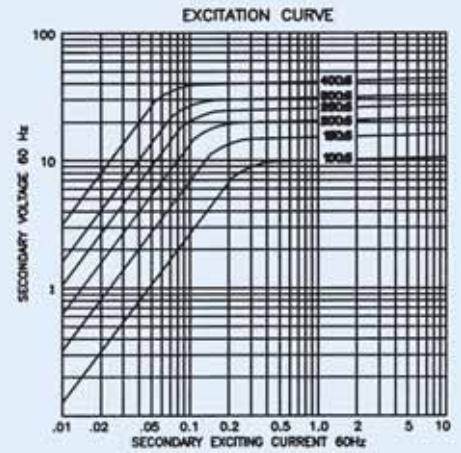

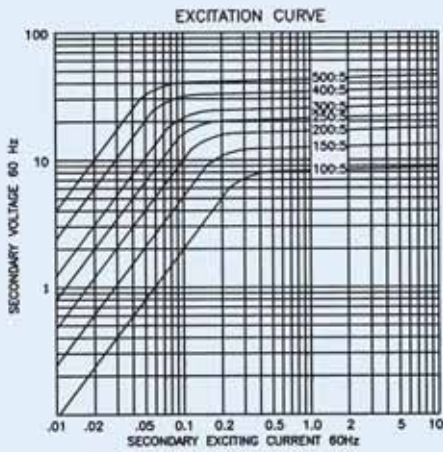

Model 192

Window Diameter 1.75"

- Approximate weight: 4.75 lbs

Catalogue Number	Current Ratio	Relay Class	ANSI metering class at 60Hz					Secondary winding resistance (OHMS @ 75 °C)	Continuous thermal rating factor	
			B0.1	B0.2	B0.5	B0.9	B1.8		@30 °C	@55 °C
192 - 101	100:5*	-	0.6	1.2	2.4	4.8	-	0.031	2.0	2.0
192 - 151	150:5*	-	0.6	0.6	1.2	2.4	4.8	0.058	2.0	2.0
192 - 201	200:5*	C10	0.3	0.3	0.6	1.2	2.4	0.063	2.0	1.5
192 - 251	250:5*	C10	0.3	0.3	0.3	0.6	1.2	0.097	2.0	1.5
192 - 301	300:5*	C10	0.3	0.3	0.3	0.6	1.2	0.131	2.0	1.33
192 - 401	400:5*	C20	0.3	0.3	0.3	0.3	0.6	0.174	1.5	1.0
192 - 501	500:5*	C20	0.3	0.3	0.3	0.3	0.6	0.218	1.5	1.0

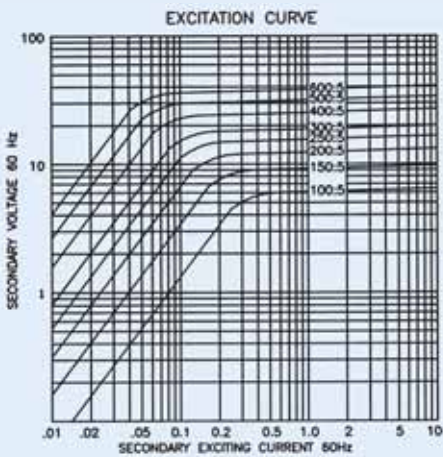

Model 193

Window Diameter 2.13"

- Approximate weight: 4.25 lbs.

Catalogue Number	Current Ratio	Relay Class	ANSI metering class at 60Hz					Secondary winding resistance (OHMS @ 75 °C)	Continuous thermal rating factor	
			B0.1	B0.2	B0.5	B0.9	B1.8		@30 °C	@55 °C
193 - 101	100:5	-	1.2	1.2	4.8	-	-	0.024	2.0	2.0
193 - 151	150:5	-	0.6	0.6	1.2	2.4	4.8	0.038	2.0	2.0
193 - 201	200:5	-	0.3	0.3	1.2	1.2	2.4	0.071	2.0	2.0
193 - 251	250:5	C10	0.3	0.3	0.6	1.2	2.4	0.072	2.0	1.5
193 - 301	300:5	C10	0.3	0.3	0.3	0.6	1.2	0.082	2.0	1.5
193 - 401	400:5	C10	0.3	0.3	0.3	0.3	0.6	0.142	1.5	1.33
193 - 501	500:5	C20	0.3	0.3	0.3	0.3	0.6	0.159	1.5	1.33
193 - 601	600:5	C20	0.3	0.3	0.3	0.3	0.6	0.191	1.5	1.0

Model 194

Window Diameter 2.5"

Approximate weight: 3.5 lb

Catalogue Number	Current Ratio	Relay Class	ANSI metering class at 60Hz					Secondary winding resistance (OHMS @ 75 °C)	Continuous thermal rating factor	
			B0.1	B0.2	B0.5	B0.9	B1.8		@30 °C	@55 °C
194 - 101	100:5	-	1.2	2.4	4.8	-	-	0.033	2.0	2.0
194 - 151	150:5*	-	0.6	0.6	2.4	4.8	4.8	0.050	2.0	2.0
194 - 201	200:5*	-	0.3	0.3	1.2	2.4	4.8	0.065	2.0	2.0
194 - 251	250:5*	-	0.3	0.3	0.6	1.2	2.4	0.084	2.0	1.5
194 - 301	300:5*	-	0.3	0.3	0.6	1.2	2.4	0.101	2.0	1.5
194 - 401	400:5*	C10	0.3	0.3	0.3	0.6	1.2	0.104	2.0	1.5
194 - 501	500:5*	C10	0.3	0.3	0.3	0.3	0.6	0.133	1.5	1.0
194 - 601	600:5*	C10	0.3	0.3	0.3	0.3	0.6	0.180	1.5	1.0
194 - 751	750:5*	C10	0.3	0.3	0.3	0.3	0.3	0.283	1.0	0.8
194 - 801	800:5*	C10	0.3	0.3	0.3	0.3	0.3	0.302	1.0	0.8
194 - 102	1000:5*	-	0.3	0.3	0.3	0.3	0.3	0.354	1.0	0.8
194 - 122	1200:5*	-	0.3	0.3	0.3	0.3	0.3	0.425	1.0	0.8
194 - 152	1500:5*	-	0.3	0.3	0.3	0.3	0.3	0.531	1.0	0.6
194 - 162	1600:5*	-	0.3	0.3	0.3	0.3	0.3	0.566	0.8	0.6

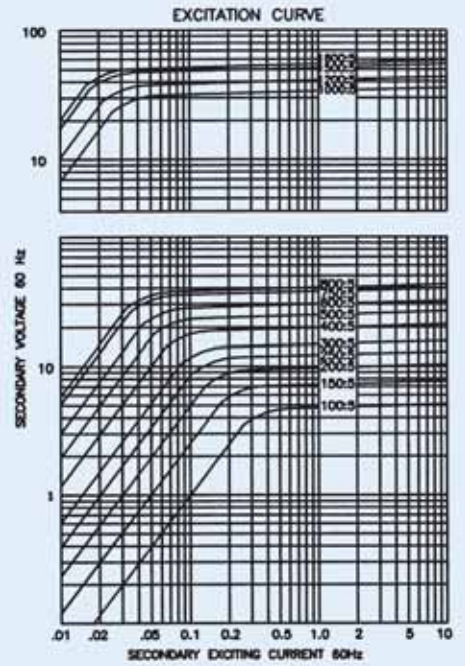

Model 195

Window Diameter 3.06"

Approximate weight: 2.25 lbs

Catalogue Number	Current Ratio	ANSI metering class at 60Hz					Secondary winding resistance (OHMS @ 75 °C)	Continuous thermal rating factor	
		B0.1	B0.2	B0.5	B0.9	B1.8		@30 °C	@55 °C
195 - 201	200:5	0.6	0.6	2.4	4.8	4.8	0.040	2.0	2.0
195 - 251	250:5	0.3	0.6	1.2	2.4	4.8	0.069	2.0	2.0
195 - 301	300:5	0.3	0.6	1.2	2.4	2.4	0.068	2.0	2.0
195 - 401	400:5	0.3	0.3	0.6	1.2	2.4	0.110	2.0	1.5
195 - 501	500:5	0.3	0.3	0.3	0.6	1.2	0.105	2.0	1.5
195 - 601	600:5	0.3	0.3	0.3	0.6	0.6	0.151	1.5	1.33
195 - 751	750:5	0.3	0.3	0.3	0.6	0.6	0.197	1.5	1.0
195 - 801	800:5	0.3	0.3	0.3	0.6	0.6	0.265	1.0	0.8
195 - 102	1000:5	0.3	0.3	0.3	0.3	0.6	0.209	1.0	0.8
195 - 122	1200:5	0.3	0.3	0.3	0.3	0.6	0.301	1.0	0.6
195 - 152	1500:5	0.3	0.3	0.3	0.3	0.3	0.471	1.0	0.6
195 - 162	1600:5	0.3	0.3	0.3	0.3	0.3	0.502	1.0	0.6
195 - 202	2000:5	0.3	0.3	0.3	0.3	0.3	0.782	0.6	0.6

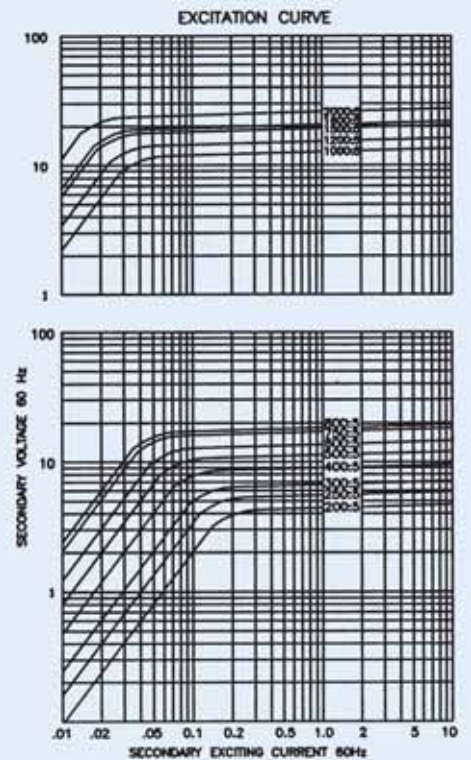

Application:
Metering

Frequency:
50 - 400Hz:

Insulation Level:

- 600 Volts, 10kV BIL full wave
- Terminals are brass studs No. 8 - 32 with one flatwasher, lockwasher and regular nut
 - Order mounting bracket kit separately
 - Multi-ratios available upon request

Approvals



Models 296, 297, 298, 299, 300

Window Diameters 1.5", 2.25", 3.0", 3.38", 3.75"

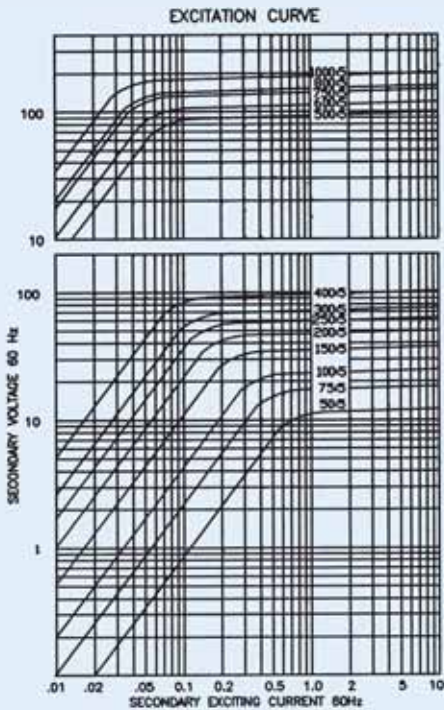
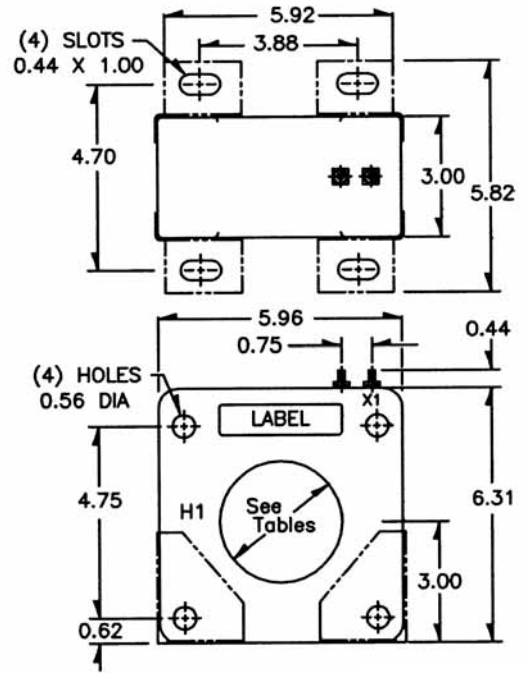
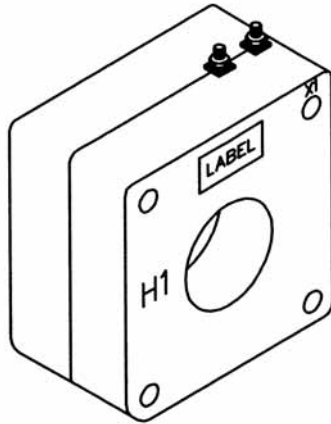

Model 193

Window Diameter 2.13"
Approximate weight: 4.25 lbs

Catalogue Number	Current Ratio	Relay Class	ANSI metering class at 60Hz					Secondary winding resistance (OHMS @ 75 °C)	Continuous thermal rating factor	
			B0.1	B0.2	B0.5	B0.9	B1.8		@30 °C	@55 °C
296 - 500	50:5	C10	1.2	2.4	4.8	-	-	0.018	2.0	2.0
296 - 750	75:5	C10	0.6	1.2	2.4	4.8	-	0.027	2.0	2.0
296 - 101	100:5*	C20	0.6	0.6	1.2	2.4	4.8	0.035	2.0	2.0
296 - 151	150:5*	C20	0.3	0.3	0.6	1.2	2.4	0.053	2.0	2.0
296 - 201	200:5*	C20	0.3	0.3	0.6	0.6	1.2	0.071	2.0	2.0
296 - 251	250:5*	C50	0.3	0.3	0.3	0.3	0.6	0.121	2.0	2.0
296 - 301	300:5*	C50	0.3	0.3	0.3	0.3	0.6	0.168	2.0	1.5
296 - 401	400:5*	C100	0.3	0.3	0.3	0.3	0.3	0.224	2.0	1.5
296 - 501	500:5	C50	0.3	0.3	0.3	0.3	0.3	0.249	1.5	1.5
296 - 601	600:5	C100	0.3	0.3	0.3	0.3	0.3	0.298	1.5	1.33
296 - 751	750:5	C100	0.3	0.3	0.3	0.3	0.3	0.373	1.5	1.0
296 - 801	800:5	C100	0.3	0.3	0.3	0.3	0.3	0.398	1.5	1.0
296 - 102	1000:5	C100	0.3	0.3	0.3	0.3	0.3	0.497	1.33	1.0

Model 297

Window Diameter 2.25"

Approximate weight: 15 lbs

Catalogue Number	Current Ratio	Relay Class	ANSI metering class at 60Hz					Secondary winding resistance (OHMS @ 75°C)	Continuous thermal rating factor	
			B0.1	B0.2	B0.5	B0.9	B1.8		@30°C	@55°C
297 - 500	50:5	-	2.4	4.8	-	-	-	0.015	2.0	2.0
297 - 750	75:5	C10	1.2	2.4	4.8	4.8	-	0.023	2.0	2.0
297 - 101	100:5	C10	0.6	1.2	2.4	4.8	4.8	0.051	2.0	2.0
297 - 151	150:5*	C20	0.6	0.6	1.2	2.4	2.4	0.048	2.0	2.0
297 - 201	200:5*	C20	0.3	0.6	0.6	1.2	2.4	0.103	2.0	2.0
297 - 251	250:5*	C20	0.3	0.3	0.3	0.6	1.2	0.111	2.0	2.0
297 - 301	300:5*	C50	0.3	0.3	0.3	0.6	1.2	0.154	2.0	1.5
297 - 401	400:5*	C50	0.3	0.3	0.3	0.3	0.6	0.205	2.0	1.5
297 - 501	500:5*	C50	0.3	0.3	0.3	0.3	0.3	0.233	2.0	1.5
297 - 601	600:5*	C100	0.3	0.3	0.3	0.3	0.3	0.308	1.5	1.33

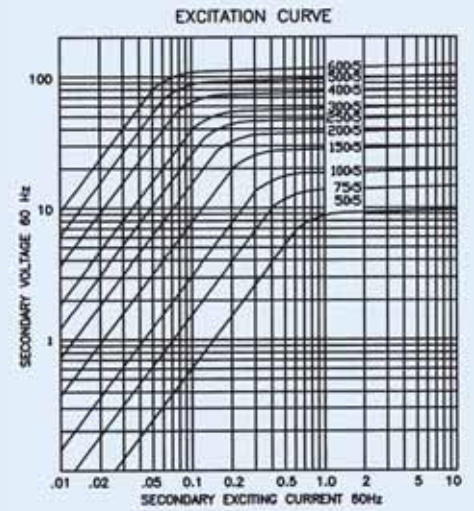

Model 298

Window Diameter 3.00"

Approximate weight: 12 lbs

Catalogue Number	Current Ratio	Relay Class	ANSI metering class at 60Hz					Secondary winding resistance (OHMS @ 75°C)	Continuous thermal rating factor	
			B0.1	B0.2	B0.5	B0.9	B1.8		@30°C	@55°C
298 - 500	50:5	-	2.4	4.8	-	-	-	0.023	2.0	2.0
298 - 750	75:5	-	1.2	1.2	4.8	-	-	0.028	2.0	2.0
298 - 101	100:5	C10	0.6	0.6	2.4	4.8	-	0.040	2.0	2.0
298 - 151	150:5*	C10	0.6	0.6	1.2	2.4	4.8	0.060	2.0	2.0
298 - 201	200:5*	C20	0.6	0.6	0.6	1.2	2.4	0.080	2.0	2.0
298 - 251	250:5*	C20	0.3	0.3	0.6	1.2	2.4	0.073	2.0	2.0
298 - 301	300:5*	C20	0.3	0.3	0.6	0.6	1.2	0.087	2.0	2.0
298 - 401	400:5*	C20	0.3	0.3	0.3	0.3	0.6	0.186	2.0	1.5
298 - 501	500:5*	C50	0.3	0.3	0.3	0.3	0.6	0.233	2.0	1.5
298 - 601	600:5*	C50	0.3	0.3	0.3	0.3	0.3	0.279	1.5	1.33
298 - 751	750:5*	C50	0.3	0.3	0.3	0.3	0.3	0.349	1.5	1.0
298 - 801	800:5*	C50	0.3	0.3	0.3	0.3	0.3	0.372	1.5	1.0

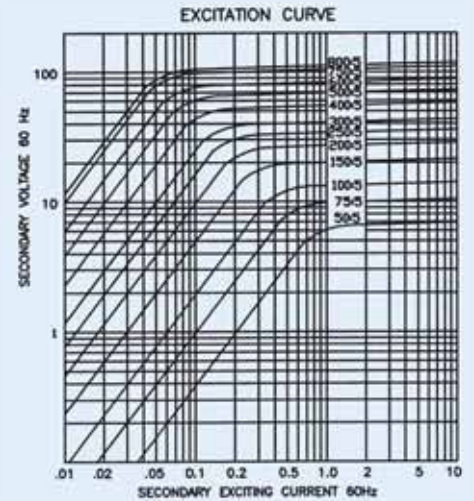

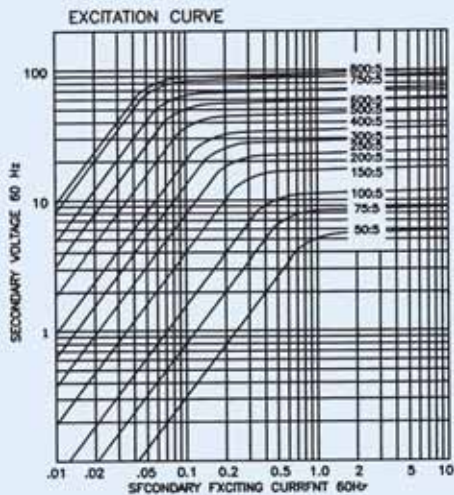

Model 299

Window Diameter 3.38"

Approximate weight: 10 lbs

Catalogue Number	Current Ratio	Relay Class	ANSI metering class at 60Hz					Secondary winding resistance (OHMS @ 75 °C)	Continuous thermal rating factor	
			B0.1	B0.2	B0.5	B0.9	B1.8		@30 °C	@55 °C
299 - 500	50:5	-	4.8	4.8	-	-	-	0.022	2.0	2.0
299 - 750	75:5	-	1.2	2.4	4.8	-	-	0.028	2.0	2.0
299 - 101	100:5	C10	0.6	1.2	2.4	4.8	-	0.038	2.0	2.0
299 - 151	150:5*	C10	0.6	0.6	1.2	2.4	4.8	0.057	2.0	2.0
299 - 201	200:5*	C10	0.6	0.6	1.2	1.2	2.4	0.088	2.0	2.0
299 - 251	250:5*	C20	0.3	0.3	0.6	1.2	2.4	0.098	2.0	2.0
299 - 301	300:5*	C20	0.3	0.3	0.3	0.6	1.2	0.118	2.0	2.0
299 - 401	400:5*	C20	0.3	0.3	0.3	0.6	0.6	0.177	2.0	1.5
299 - 501	500:5*	C20	0.3	0.3	0.3	0.3	0.6	0.221	2.0	1.5
299 - 601	600:5*	C50	0.3	0.3	0.3	0.3	0.3	0.265	1.5	1.33
299 - 751	750:5*	C50	0.3	0.3	0.3	0.3	0.3	0.331	1.5	1.0
299 - 801	800:5*	C50	0.3	0.3	0.3	0.3	0.3	0.353	1.5	1.0

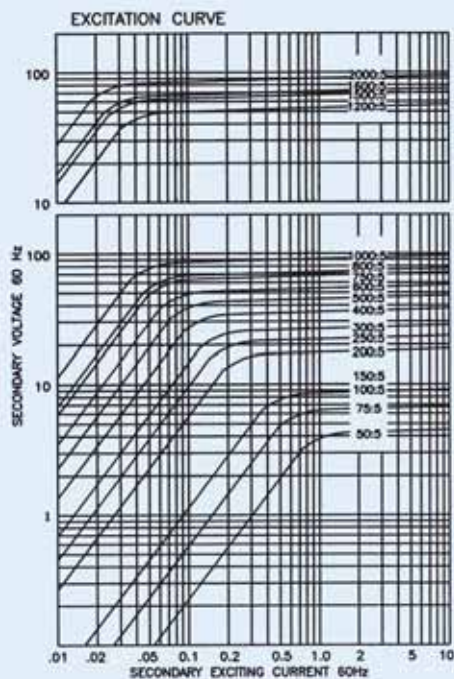

Model 300

Window Diameter 3.75"











Approximate weight: 9 lbs

Catalogue Number	Current Ratio	Relay Class	ANSI metering class at 60Hz					Secondary winding resistance (OHMS @ 75 °C)	Continuous thermal rating factor	
			B0.1	B0.2	B0.5	B0.9	B1.8		@30 °C	@55 °C
300 - 500	50:5	-	2.4	4.8	-	-	-	0.012	2.0	2.0
300 - 750	75:5	-	2.4	2.4	-	-	-	0.019	2.0	2.0
300 - 101	100:5	-	2.4	2.4	2.4	-	-	0.026	2.0	2.0
300 - 151	150:5*	-	0.6	0.6	2.4	2.4	4.8	0.054	2.0	2.0
300 - 201	200:5*	C10	0.6	0.6	1.2	2.4	4.8	0.072	2.0	2.0
300 - 251	250:5*	C10	0.3	0.6	1.2	1.2	2.4	0.104	2.0	2.0
300 - 301	300:5*	C10	0.3	0.3	0.3	0.6	1.2	0.108	2.0	2.0
300 - 401	400:5*	C20	0.3	0.3	0.3	0.6	1.2	0.144	2.0	1.5
300 - 501	500:5*	C20	0.3	0.3	0.3	0.6	0.6	0.209	2.0	1.5
300 - 601	600:5*	C20	0.3	0.3	0.3	0.3	0.6	0.251	1.5	1.33
300 - 751	750:5*	C20	0.3	0.3	0.3	0.3	0.3	0.329	1.5	1.0
300 - 801	800:5*	C50	0.3	0.3	0.3	0.3	0.3	0.334	1.5	1.0
300 - 102	1000:5*	C50	0.3	0.3	0.3	0.3	0.3	0.415	1.33	1.0
300 - 122	1200:5*	C10	0.3	0.3	0.3	0.3	0.3	0.425	1.33	1.0
300 - 152	1500:5*	C10	0.3	0.3	0.3	0.3	0.3	0.531	1.0	1.0
300 - 162	1600:5*	C10	0.3	0.3	0.3	0.3	0.3	0.567	1.0	0.8
300 - 202	2000:5*	C20	0.3	0.3	0.3	0.3	0.3	0.708	1.0	0.8

3 Phase Current Transformers

600V Class
For Metering and Relaying

600V Three Phase
Current Transformers
ANSI Rated
Window Type

Contents				Page	Contents				Page
Window Dia.	Phase Centre	Models	Body Sizes		Window Dia.	Phase Centre	Models	Body Sizes	
	4.50	3P40	W 13.75 H 5.19 D 2.25	80		4.00	3P91	W 12.80 H 5.31 D 2.63	88
	4.50	3P41	W 13.75 H 5.19 D 2.25	81	Window Size 2.56 2.12	4.00	3P92	W 12.80 H 5.31 D 2.63	89
	4.50	3P42	W 13.75 H 5.16 D 2.25	82		4.00	3P93	W 12.80 H 5.31 D 2.63	90
	4.50	3P43	W 13.75 H 5.19 D 2.25	83	Window Dia. 2.88	4.00	3P93	W 12.80 H 5.31 D 2.63	90
1.00 1.63 2.00 	2.75	3P80 3P81 3P82	W 8.50 H 4.14 D 2.00	84					
Window Size W1.55 HO.45 W1.55 HO.25 	2.75	3P83 3P86 3P84 (page 86)	W 8.50 H 4.14 D 2.00	85 86					
Window Dia. 1.63 	4.00	3P90	W 12.80 H 5.31 D 2.63	87					

Application:

3 phase relay, metering and meter overload protection

Frequency:

50 - 400Hz

Insulation Level:

- 600 Volts, 10kV BIL full wave
- Terminals are brass studs No. 8 - 32 with one flatwasher, lockwasher and regular nut
- Approximate weight: 14 lbs

Approvals



Model 3P40

Window Diameter 1.75"

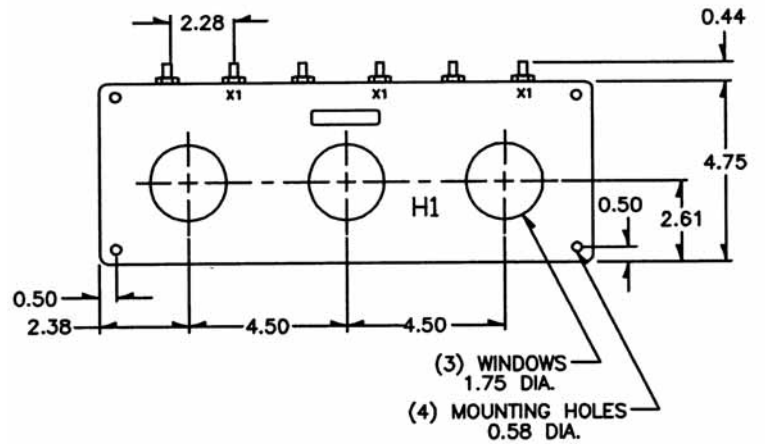
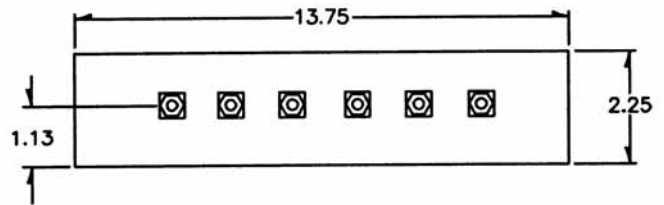
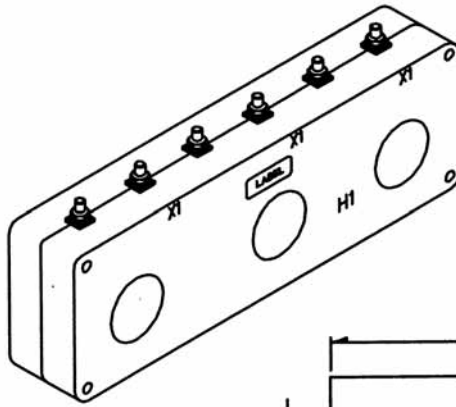

EXCITATION CURVE

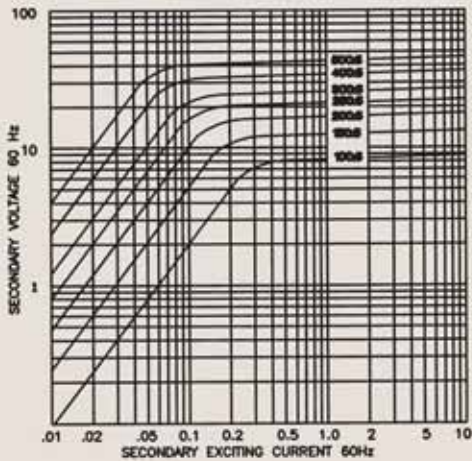

Catalogue Number	Current Ratio	Relay Class	ANSI metering class at 60Hz					Secondary winding resistance (OHMS @ 75°C)
			B0.1	B0.2	B0.5	B0.9	B1.8	
3P40-101	100:5	-	0.6	1.2	2.4	-	-	0.033
3P40-151	150:5	-	0.6	0.6	1.2	2.4	-	0.049
3P40-201	200:5	C10	0.3	0.6	0.6	1.2	2.4	0.082
3P40-251	250:5	C10	0.3	0.3	0.6	0.6	1.2	1.103
3P40-301	300:5	C20	0.3	0.3	0.3	0.6	1.2	1.124
3P40-401	400:5	C20	0.3	0.3	0.3	0.6	1.2	0.131
3P40-501	500:5	C20	0.3	0.3	0.3	0.3	0.6	0.163

Model 3P41

Window Diameter 2.03"

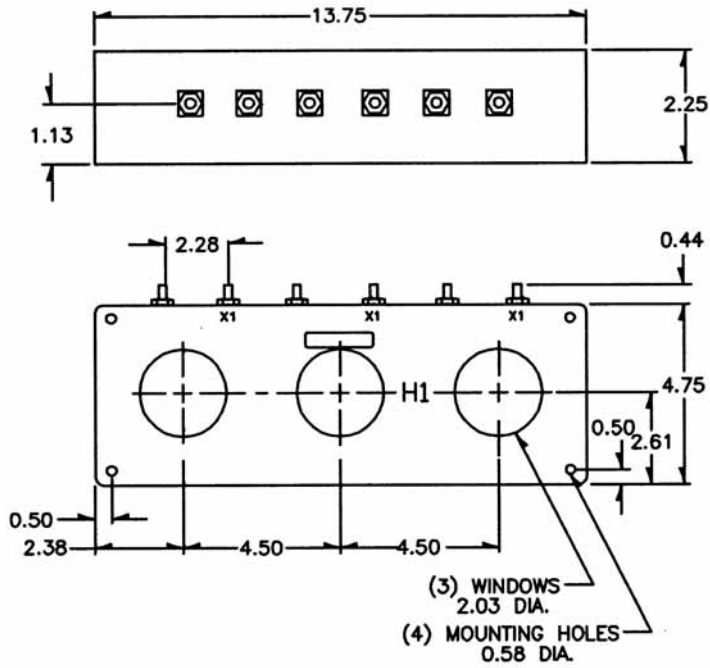
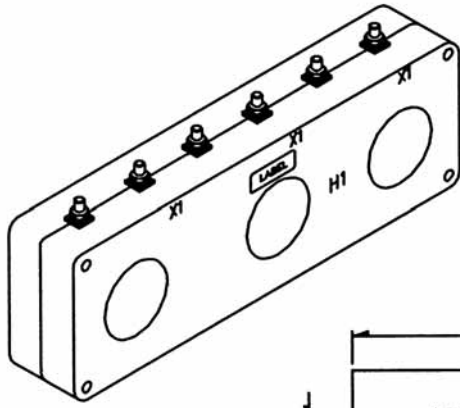

Catalogue Number	Current Ratio	Relay Class	ANSI metering class at 60Hz					Secondary winding resistance (OHMS @ 75°C)
			B0.1	B0.2	B0.5	B0.9	B1.8	
3P41-101	100:5	-	1.2	1.2	2.4	-	-	0.030
3P41-151	150:5	-	0.6	0.6	1.2	2.4	-	0.045
3P41-201	200:5	-	0.3	0.6	1.2	2.4	2.4	0.075
3P41-251	250:5	C10	0.3	0.3	0.6	1.2	2.4	0.094
3P41-301	300:5	C10	0.3	0.3	0.3	0.6	1.2	0.090
3P41-401	400:5	C10	0.3	0.3	0.3	0.3	0.6	0.151
3P41-501	500:5	C20	0.3	0.3	0.3	0.3	0.6	0.149
3P41-601	600:5	C20	0.3	0.3	0.3	0.3	0.6	0.179

Application:

3 phase relay, metering and motor overload protection.

Frequency:

50 - 400Hz

Insulation Level:

600 Volts, 10kV BIL full wave

- Terminals are brass studs No. 8 - 32 with one flat washer, lockwasher and regular nut
- Approximate weight: 12 lbs

Approvals



UL 257877

CSA 223647

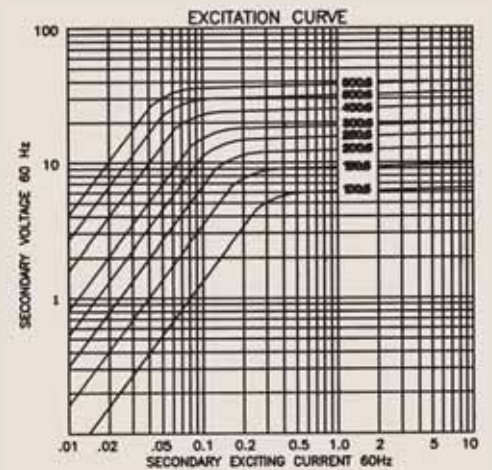

Application:

3 phase relay, metering and motor overload protection.

Frequency:

50 - 400Hz

Insulation Level:

- 600 Volts, 10kV BIL full wave
- Terminals are brass studs No. 8 - 32 with one flatwasher, lockwasher and regular nut
- Approximate weight: 11.5 lbs

Approvals



Model 3P42

Window Diameter 2.5"

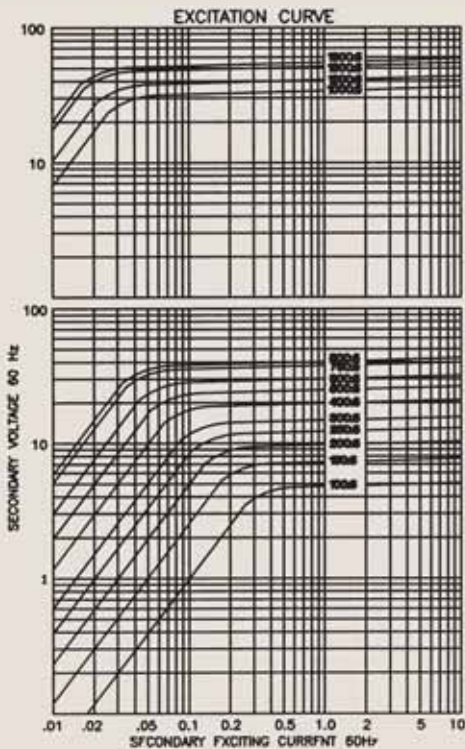
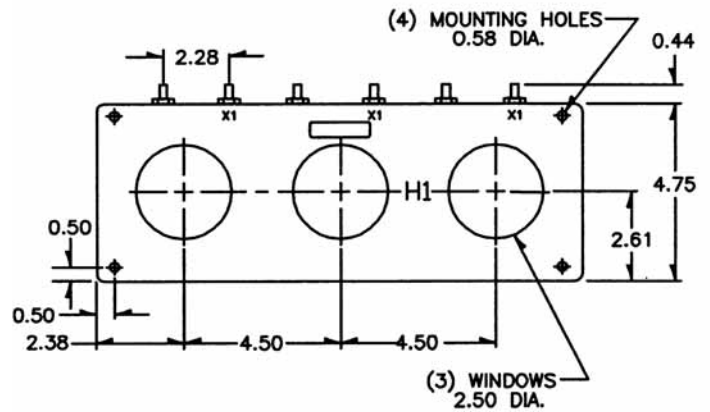
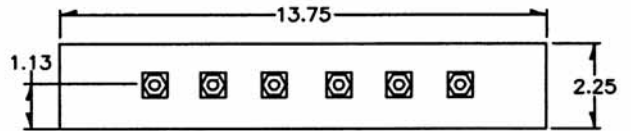
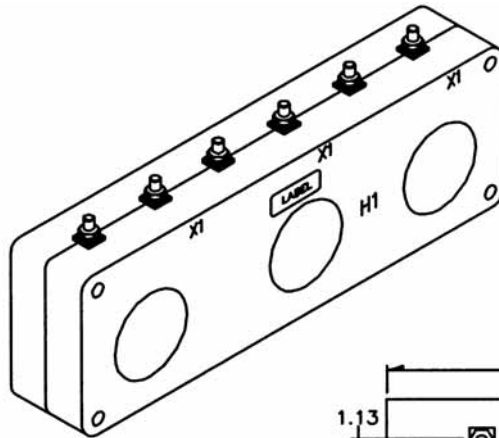

Catalogue Number	Current Ratio	Relay Class	ANSI metering class at 60Hz					Secondary winding resistance (OHMS @ 75 °C)
			B0.1	B0.2	B0.5	B0.9	B1.8	
3P42-101	100:5	-	1.2	2.4	-	-	-	0.035
3P42-151	150:5	-	0.6	1.2	-	-	-	0.053
3P42-201	200:5	-	0.6	0.6	1.2	-	-	0.071
3P42-251	250:5	-	0.3	0.3	1.2	-	-	0.088
3P42-301	300:5	-	0.3	0.3	0.6	1.2	2.4	0.106
3P42-401	400:5	C10	0.3	0.3	0.6	0.6	1.2	0.112
3P42-501	500:5	C10	0.3	0.3	0.3	0.6	1.2	0.140
3P42-601	600:5	C10	0.3	0.3	0.3	0.6	0.6	0.168
3P42-751	750:5	C20	0.3	0.3	0.3	0.6	0.6	0.265
3P42-801	800:5	C20	0.3	0.3	0.3	0.3	0.3	0.283
3P42-102	1000:5	C10	0.3	0.3	0.3	0.3	0.3	0.308
3P42-122	1200:5	C10	0.3	0.3	0.3	0.3	0.3	0.365
3P42-152	1500:5	C20	0.3	0.3	0.3	0.3	0.3	0.462
3P42-162	1600:5	C20	0.3	0.3	0.3	0.3	0.3	0.492

Model 3P43

Window Diameter 3.00"

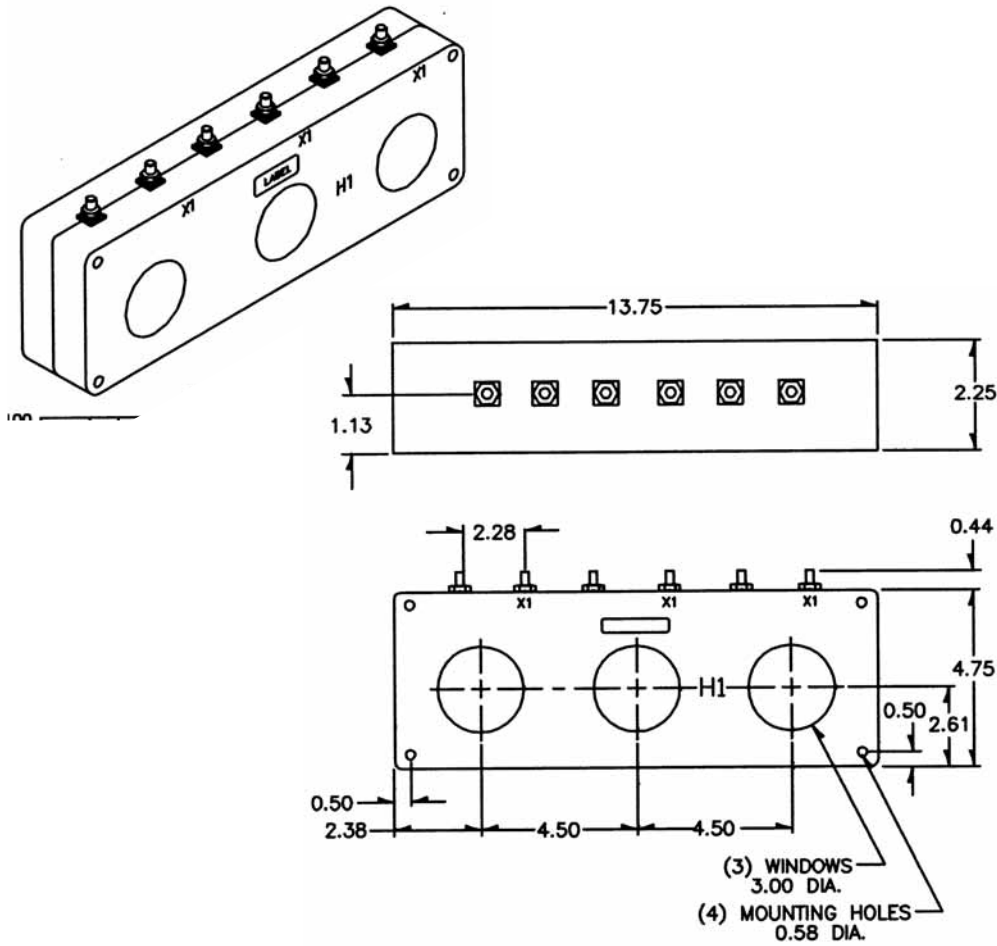

Catalogue Number	Current Ratio	ANSI metering class at 60Hz					Secondary winding resistance (OHMS @ 75°C)
		B0.1	B0.2	B0.5	B0.9	B1.8	
3P43-201	200:5	0.6	1.2	2.4	-	-	0.049
3P43-251	250:5	0.3	0.6	1.2	2.4	-	0.077
3P43-301	300:5	0.3	0.6	1.2	2.4	-	0.073
3P43-401	400:5	0.3	0.3	0.6	1.2	-	0.123
3P43-501	500:5	0.3	0.3	0.6	0.6	1.2	0.122
3P43-601	600:5	0.3	0.3	0.3	0.6	1.2	0.184
3P43-751	750:5	0.3	0.3	0.3	0.6	1.2	0.182
3P43-801	800:5	0.3	0.3	0.3	0.6	1.2	0.246
3P43-102	1000:5	0.3	0.3	0.3	0.3	0.6	0.307
3P43-122	1200:5	0.3	0.3	0.3	0.3	1.2	0.315
3P43-152	1500:5	0.3	0.3	0.3	0.3	1.2	0.395
3P43-162	1600:5	0.3	0.3	0.3	0.3	0.6	0.428
3P43-202	2000:5	0.3	0.3	0.3	0.3	0.6	0.532

Application:

3 phase relay, metering and meter overload protection.

Frequency:

50 - 400Hz:

Insulation Level:

600 Volts, 10kV BIL full wave

- Terminals are brass studs No. 8 - 32 with one flat washer, lockwasher and regular nut
- Flexible leads UL 1015 105°C, CSA approved #16AWG, 24" long are available
- Approximate weight: 8.5 lbs

Approvals

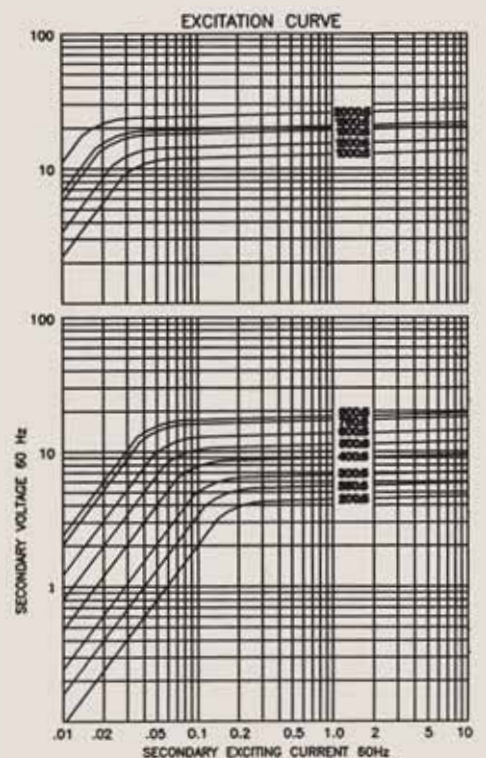

Application:

3 phase relay, metering and motor overload protection.

Frequency:

50 - 400Hz

Insulation Level:

- 600 Volts, 10kV BIL full wave
- Terminals are brass studs No. 8 - 32 with one flatwasher, lockwasher and regular nut
- Flexible leads UL 1015 105°C, CSA approved, #16AWG, 24" long are available
- Approximate weight: 4 lbs

Approvals



Models 3P80, 3P81, 3P82

Window Diameters 1.0", 1.63", 2.0"

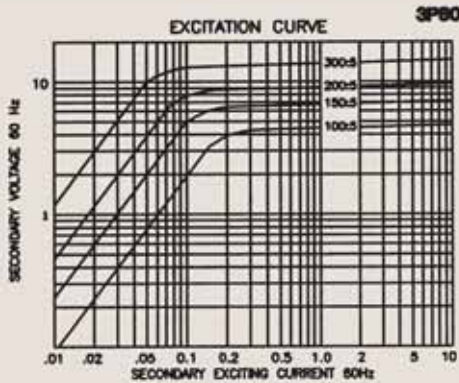
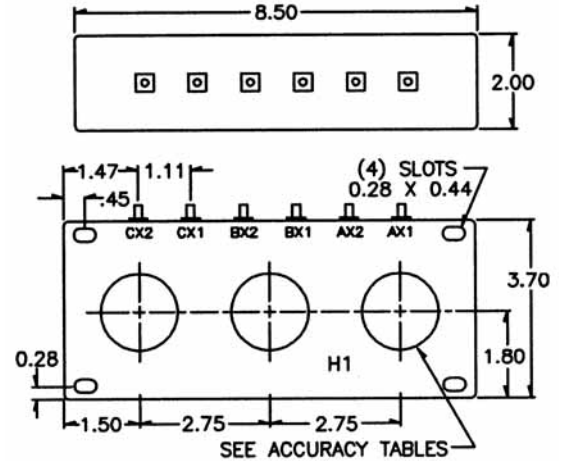
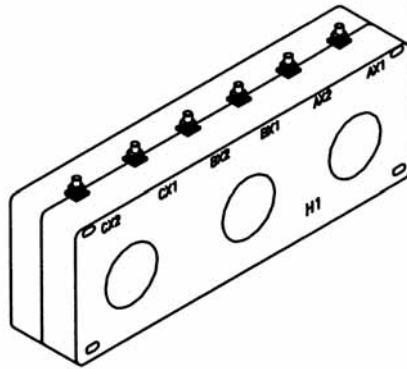

3P80 (1.00" DIA. WINDOW)

Catalogue Number	Current Ratio	V.A. for ± 1% Class	ANSI metering class at 60Hz					Secondary winding resistance (OHMS @ 75 °C)
			B0.1	B0.2	B0.5	B0.9	B1.8	
3P80-101	100:5	7.5	2.4	2.4	4.8	-	-	0.034
3P80-151	150:5	10	1.2	1.2	2.4	4.8	-	0.052
3P80-201	200:5	20	0.6	1.2	2.4	2.4	4.8	0.069
3P80-301	300:5	30	0.6	0.6	1.2	2.4	2.4	0.103

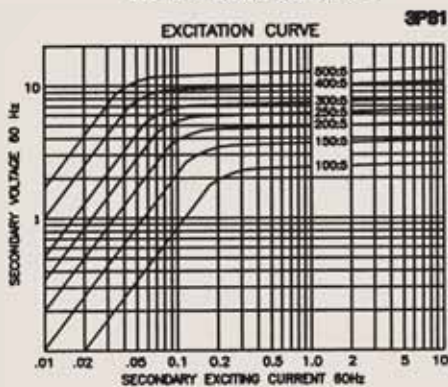

3P81 (1.63" DIA. WINDOW)

Catalogue Number	Current Ratio	V.A. for ± 1% Class	ANSI metering class at 60Hz					Secondary winding resistance (OHMS @ 75 °C)
			B0.1	B0.2	B0.5	B0.9	B1.8	
3P81-101	100:5	2.5	2.4	4.8	-	-	-	0.031
3P81-151	150:5	7.5	2.4	2.4	4.8	-	-	0.046
3P81-201	200:5	10	1.2	1.2	2.4	4.8	-	0.061
3P81-251	250:5	12	0.6	1.2	2.4	4.8	-	0.077
3P81-301	300:5	20	0.6	0.6	1.2	2.4	4.8	0.092
3P81-401	400:5	25	0.6	0.6	1.2	2.4	4.8	0.122
3P81-501	500:5	40	0.6	0.6	1.2	1.2	2.4	0.153

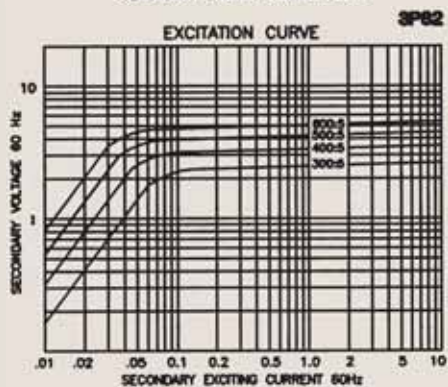

3P82 (2.0" DIA. WINDOW)

*Catalogue Number	Current Ratio	V.A. for ± 1% Class	ANSI metering class at 60Hz					Secondary winding resistance (OHMS @ 75 °C)
			B0.1	B0.2	B0.5	B0.9	B1.8	
3P82-101	300:5	2	2.4	2.4	4.8	-	-	0.106
3P82-401	400:5	4	1.2	2.4	2.4	4.8	-	0.142
3P82-501	500:5	7	1.2	1.2	2.4	2.4	-	0.177
3P82-601	600:5	10	1.2	1.2	2.4	2.4	4.8	0.212

NOTE: Holes at the top of the transformer case can be used for attaching auxiliary device mounting plate (not supplied). If the application requires transformer mounted relays, etc., then transformer can be ordered with secondary leads configured in various ways (consult factory).

Models 3P83, 3P86

Window Sizes 1.55 x 0.45", 1.55 x 0.25"

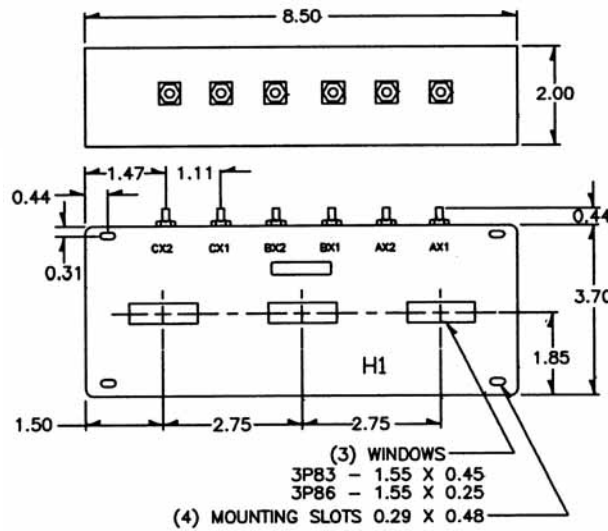
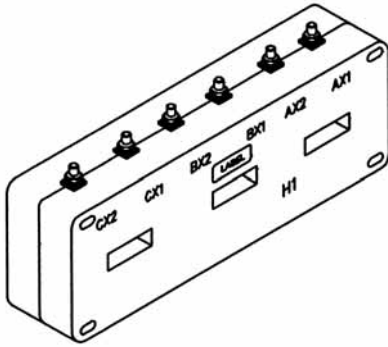

*Catalogue Number	Current Ratio	V.A. for 1% Class	ANSI metering class at 60Hz					Secondary winding resistance (OHMS @ 75°C)
			B0.1	B0.2	B0.5	B0.9	B1.8	
3P83-500	50:5	2.5	4.8	-	-	-	-	0.015
3P83-100	100:5	2.5	2.4	2.4	4.8	-	-	0.030
3P83-151	150:5	7.5	1.2	1.2	2.4	4.8	4.8	0.045
3P83-201	200:5	10.0	0.6	1.2	2.4	2.4	4.8	0.061
3P83-251	250:5	12.0	0.6	0.6	1.2	2.4	2.4	0.076
3P83-301	300:5	20.0	0.3	0.6	1.2	1.2	2.4	0.091
3P83-401	400:5	25.0	0.3	0.6	0.6	1.2	1.2	0.122
3P83-501	500:5	40.0	0.3	0.3	0.3	0.6	1.2	0.153
3P83-601	600:5	40.0	0.3	0.3	0.3	0.6	0.6	0.161
3P83-801	800:5	60.0	0.3	0.3	0.3	0.3	0.6	0.215

*For Model 3P86 change prefix.

Application:

3 phase relay, metering and motor overload protection.

Frequency:

50 - 400Hz:

Insulation Level:

600 Volts, 10kV BIL full wave

- Terminals are brass studs No. 8 - 32 with one flatwasher, lockwasher and regular nut
- Flexible leads UL 1015 105°C, CSA approved, #16AWG, 24" long are available
- Approximate weight: 4 lbs

Approvals

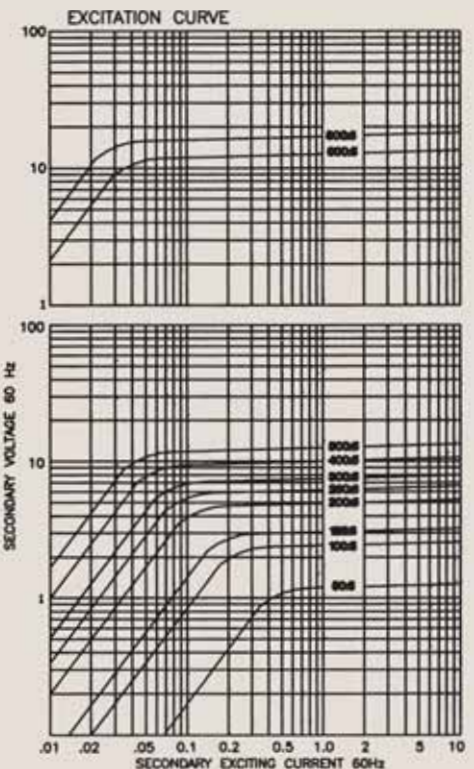

Application:

3 phase relay, metering and motor overload protection.

Frequency:

50 - 400Hz

Insulation Level:

- 600 Volts, 10kV BIL full wave
- Terminals are brass studs No. 8 - 32 with one flatwasher, lockwasher and regular nut
- Flexible leads UL 1015 105°C, CSA approved, #16AWG, 24" long are available
- Approximate weight: 4 lbs

Approvals

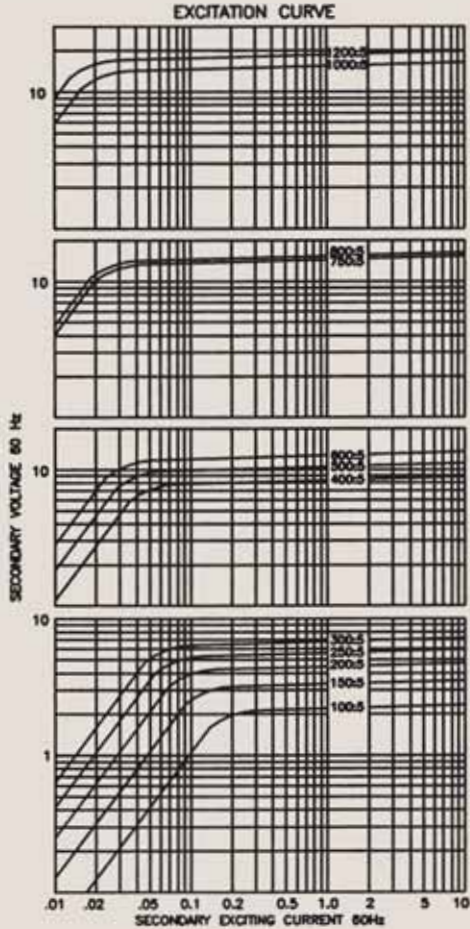

Model 3P84

Window Size 2.05" x 0.50"

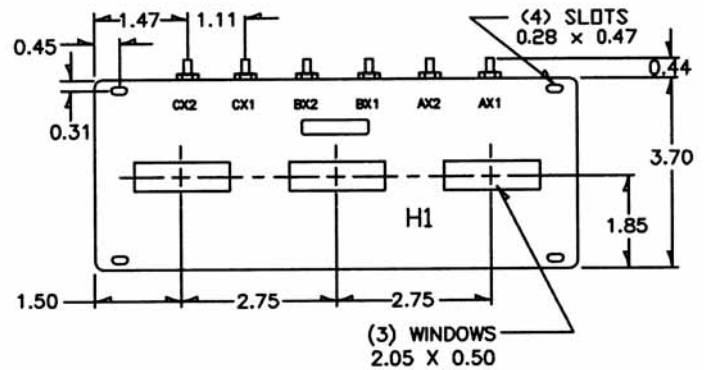
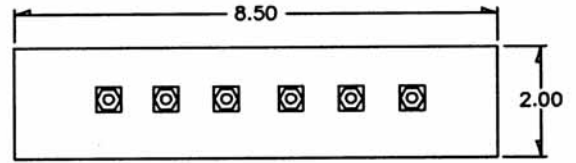
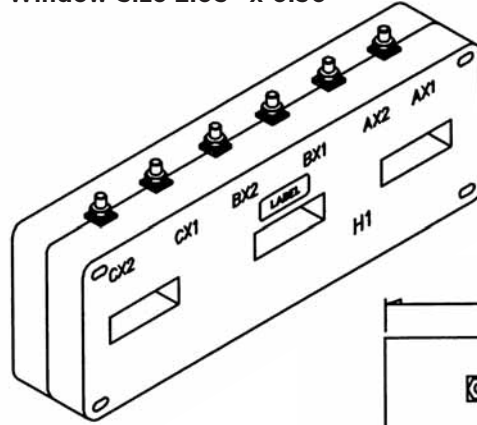

*Catalogue Number	Current Ratio	V.A. for 1% Class	ANSI metering class at 60Hz					Secondary winding resistance (OHMS @ 75°C)
			B0.1	B0.2	B0.5	B0.9	B1.8	
3P84-101	100:5	-	2.4	4.8	-	-	-	0.035
3P84-151	150:5	1	1.2	2.4	4.8	-	-	0.052
3P84-201	200:5	2	1.2	1.2	2.4	4.8	-	0.070
3P84-251	250:5	5	0.6	1.2	2.4	2.4	-	0.087
3P84-301	300:5	10	0.6	0.6	1.2	2.4	4.8	0.105
3P84-401	400:5	20	0.6	0.6	1.2	1.2	2.4	0.132
3P84-501	500:5	25	0.3	0.6	0.6	1.2	1.2	0.165
3P84-601	600:5	40	0.3	0.3	0.6	0.6	1.2	0.198
3P84-751	750:5	50	0.3	0.3	0.6	0.6	1.2	0.268
3P84-801	800:5	60	0.3	0.3	0.6	0.6	0.6	0.285
3P84-102	1000:5	60	0.3	0.3	0.3	0.6	0.6	0.317
3P84-122	1200:5	70	0.3	0.3	0.3	0.3	0.6	0.380

*For Model 3P86 change prefix.

NOTE: Holes at the top of the transformer case can be used for attaching auxiliary device mounting plate (not supplied). If the application requires transformer mounted relays, etc., then transformer can be ordered with secondary leads configured in various ways (consult factory).

Originally designed for use with moulded case circuit breaker and motor starters with 2.75 bus centre lines. Can be mounted directly on busbar and held in place with roll pins inserted in bus.

Model 3P90

Window Diameter 1.63"

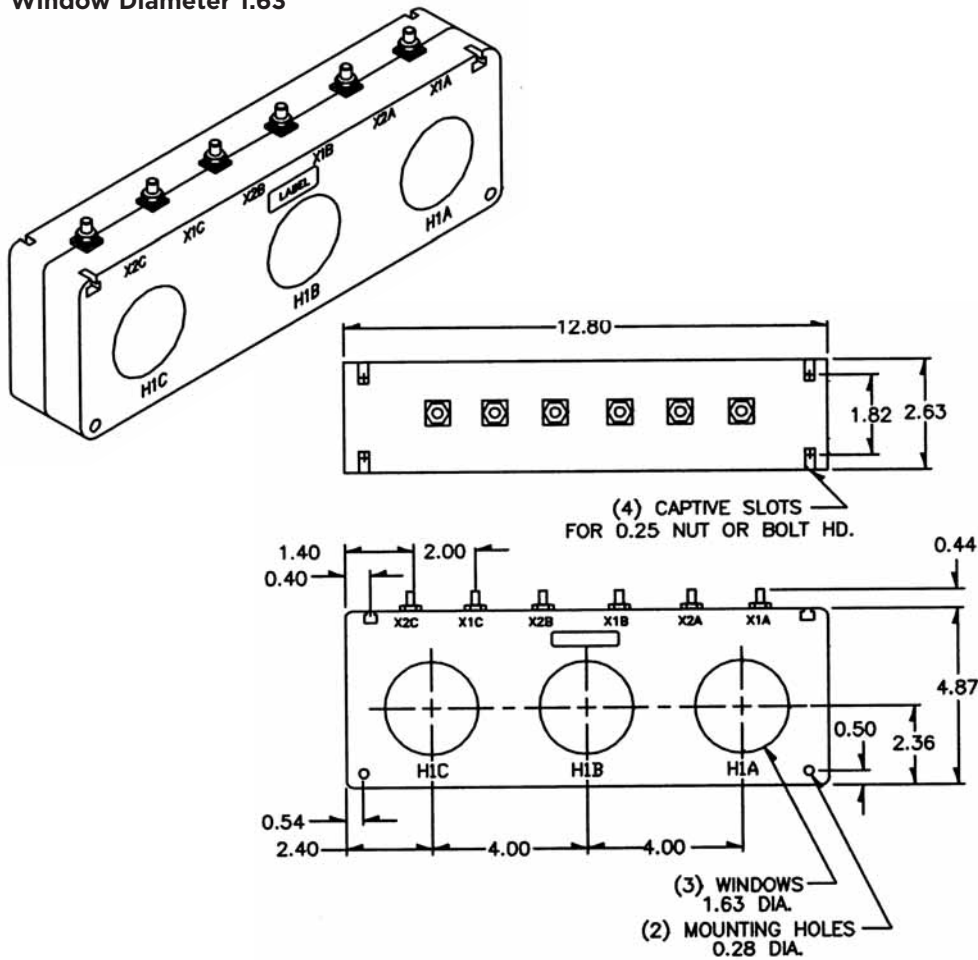

Catalogue Number	Current Ratio	V.A. for 1% Class	ANSI metering class at 60Hz					Secondary winding resistance (OHMS @ 75°C)
			B0.1	B0.2	B0.5	B0.9	B1.8	
3P90-500	50:5	1	2.4	4.8	-	-	-	0.017
3P90-101	100:5	5	0.6	1.2	2.4	4.8	-	0.035
3P90-151	150:5	7.5	0.6	0.6	1.2	2.4	4.8	0.053
3P90-201	200:5	15	0.3	0.3	1.2	1.2	2.4	0.070
3P90-251	250:5	25	0.3	0.3	0.6	0.6	2.4	0.088
3P90-301	300:5	35	0.3	0.3	0.3	0.6	1.2	0.106
3P90-401	400:5	75	0.3	0.3	0.3	0.6	1.2	0.141
3P90-501	500:5	125	0.3	0.3	0.3	0.3	0.6	0.223
3P90-601	600:5	135	0.3	0.3	0.3	0.3	0.6	0.225
3P90-751	750:5	175	0.3	0.3	0.3	0.3	0.6	0.281
3P90-801	800:5	200	0.3	0.3	0.3	0.3	0.3	0.300
3P90-102	1000:5	225	0.3	0.3	0.3	0.3	0.3	0.375

NOTE: Holes at the top of the transformer case can be used for attaching auxiliary device mounting plate (not supplied).

If the application requires transformer mounted relays, etc., then transformer can be ordered with secondary leads configured in various ways (consult factory).

Application:

3 phase relay, metering and motor overload protection.

Frequency:

50 - 400Hz:

Insulation Level:

- 600 Volts, 10kV BIL full wave
- Terminals are brass studs No. 8 - 32 with one flatwasher, lockwasher and regular nut
- Flexible leads UL 1015 105°C, CSA approved, #16AWG, 24" long are available
- Approximate weight: 7 lbs

Approvals

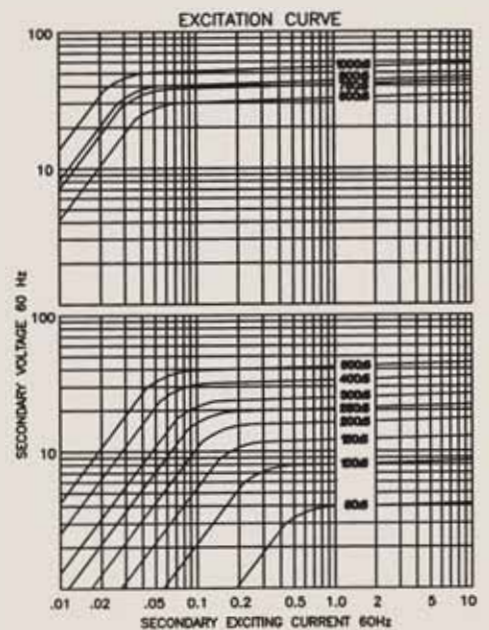

Application:

3 phase relay, metering and motor overload protection.

Frequency:

50 - 400Hz

Insulation Level:

- 600 Volts, 10kV BIL full wave
- Terminals are brass studs No. 8 - 32 with one flatwasher, lockwasher and regular nut
- Flexible leads UL 1015 105°C, CSA approved, #16AWG, 24" long are available
- Approximate weight: 7 lbs

Approvals



Model 3P91

Window Diameter 2.12"

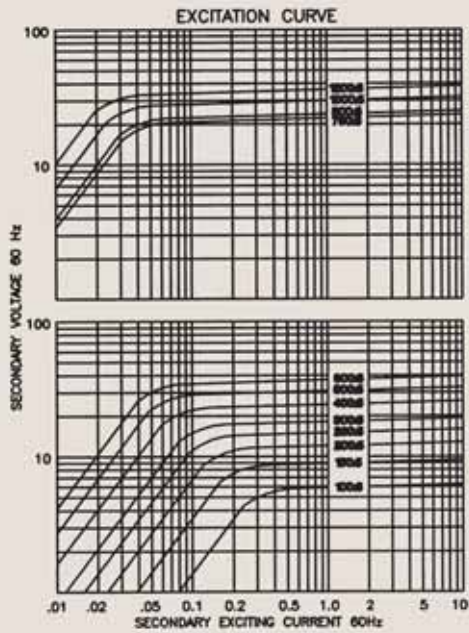
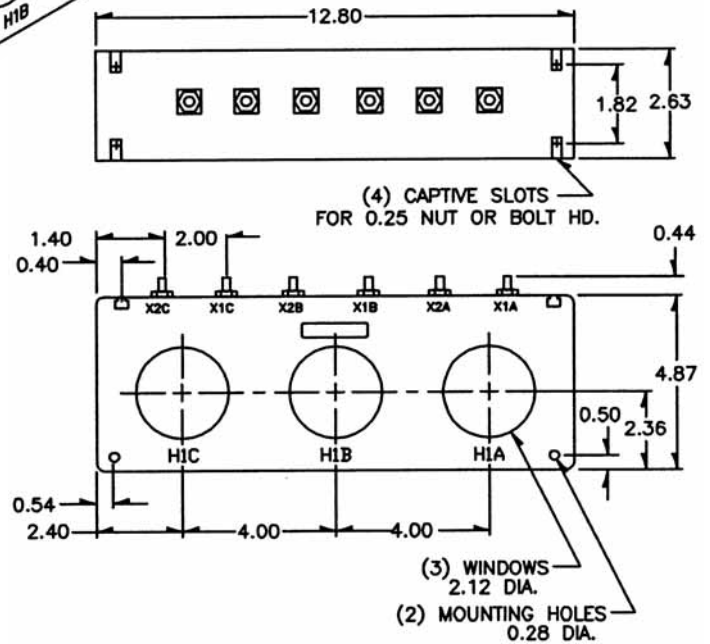
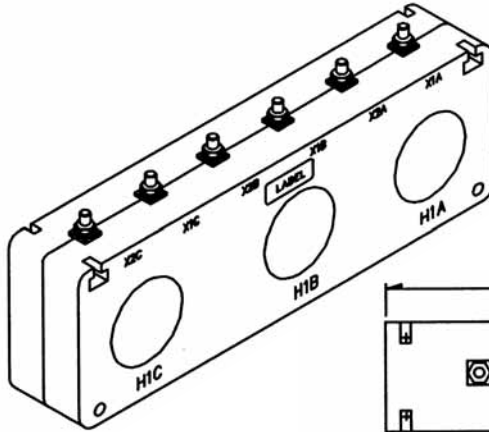

Catalogue Number	Current Ratio	V.A. for 1% Class	ANSI metering class at 60Hz					Secondary winding resistance (OHMS @ 75 °C)
			B0.1	B0.2	B0.5	B0.9	B1.8	
3P91-101	100:5	5	1.2	1.2	4.8	4.8	-	0.032
3P91-151	150:5	5	0.6	0.6	2.4	4.8	-	0.048
3P91-201	200:5	12.5	0.6	0.6	1.2	2.4	4.8	0.064
3P91-251	250:5	20	0.3	0.3	0.6	1.2	2.4	0.080
3P91-301	300:5	35	0.3	0.3	0.6	1.2	2.4	0.097
3P91-401	400:5	50	0.6	0.3	0.3	0.6	1.2	0.129
3P91-501	500:5	80	0.3	0.3	0.3	0.6	1.2	0.162
3P91-601	600:5	85	0.3	0.3	0.3	0.6	0.6	0.194
3P91-751	750:5	90	0.3	0.3	0.3	0.6	0.6	0.196
3P91-801	800:5	100	0.3	0.3	0.3	0.3	0.6	0.209
3P91-102	1000:5	125	0.3	0.3	0.3	0.3	0.6	0.261
3P91-122	1200:5	150	0.3	0.3	0.3	0.3	0.3	0.314

NOTE: Captive slots on top of transformer case can be used for attaching auxiliary device mounting plate (not supplied).

If the application requires transformer mounted relays, etc., then transformer can be ordered with secondary leads configured in various ways (consult factory).

Model 3P92

Window Size 2.56" x 2.12"

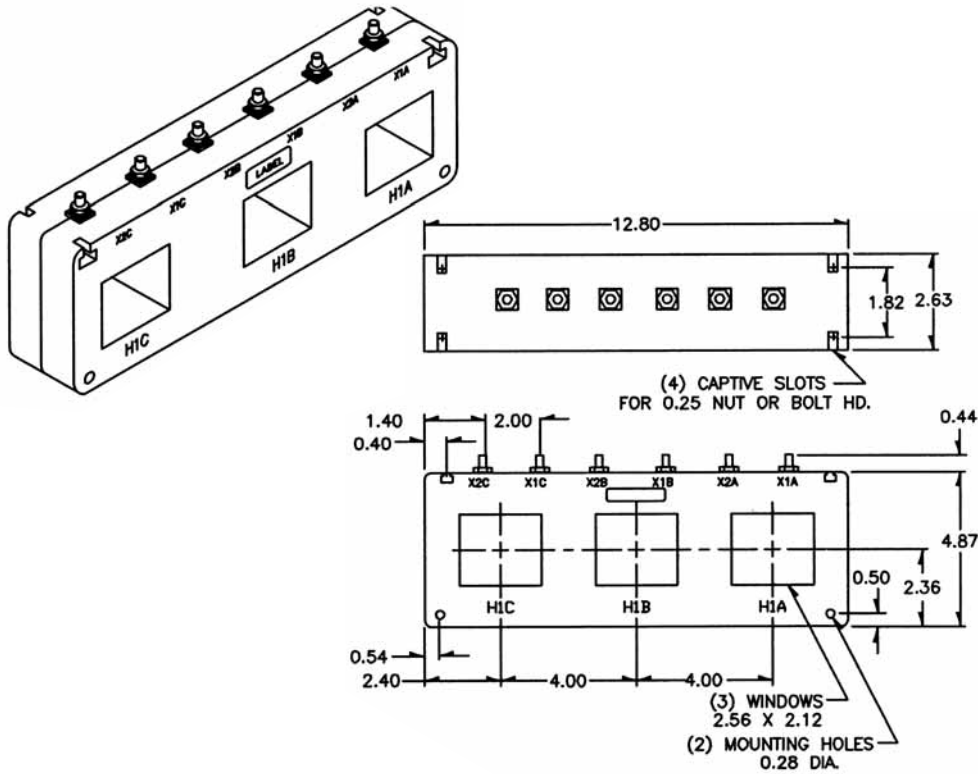

Catalogue Number	Current Ratio	V.A. for 1% Class	ANSI metering class at 60Hz					Secondary winding resistance (OHMS @ 75°C)
			B0.1	B0.2	B0.5	B0.9	B1.8	
3P90-500	50:5	1	2.4	4.8	-	-	-	0.017
3P92-101	100:5	2.5	2.4	2.4	4.8	-	-	0.012
3P92-151	150:5	5	1.2	1.2	2.4	-	-	0.023
3P92-201	200:5	5	0.6	0.6	2.4	4.8	-	0.036
3P92-251	250:5	7.5	0.6	0.6	1.2	2.4	-	0.045
3P92-301	300:5	10	0.6	0.6	1.2	2.4	-	0.054
3P92-401	400:5	15	0.3	0.3	0.6	1.2	2.4	0.076
3P92-501	500:5	20	0.3	0.3	0.3	0.6	1.2	0.095
3P92-601	600:5	25	0.3	0.3	0.3	0.6	1.2	0.150
3P92-751	750:5	25	0.3	0.3	0.3	0.6	1.2	0.187
3P92-801	800:5	35	0.3	0.3	0.3	0.6	0.6	0.200
3P92-102	1000:5	30	0.3	0.3	0.3	0.6	0.6	0.177
3P92-122	1200:5	35	0.3	0.3	0.3	0.3	0.6	0.213
3P92-152	1500:5	45	0.3	0.3	0.3	0.3	0.6	0.266
3P92-162	1600:5	50	0.3	0.3	0.3	0.3	0.3	0.284
3P92-202	2000:5	60	0.3	0.3	0.3	0.3	0.3	0.441
3P92-252	2500:5	75	0.3	0.3	0.3	0.3	0.3	0.683

NOTE: Captive slots on top of transformer case can be used for attaching auxiliary device mounting plate (not supplied).

If the application requires transformer mounted relays, etc., then transformer can be ordered with secondary leads configured in various ways (consult factory).

Application:

3 phase way, metering and motor overload protection.

Frequency:

50 - 400Hz:

Insulation Level:

- 600 Volts, 10kV BIL full wave
- Terminals are brass studs No. 8 - 32 with one flatwasher, lockwasher and regular nut
- Flexible leads UL 1015 105°C, CSA approved, #16AWG, 24" long are available
- Approximate weight: 7 lbs

Approvals

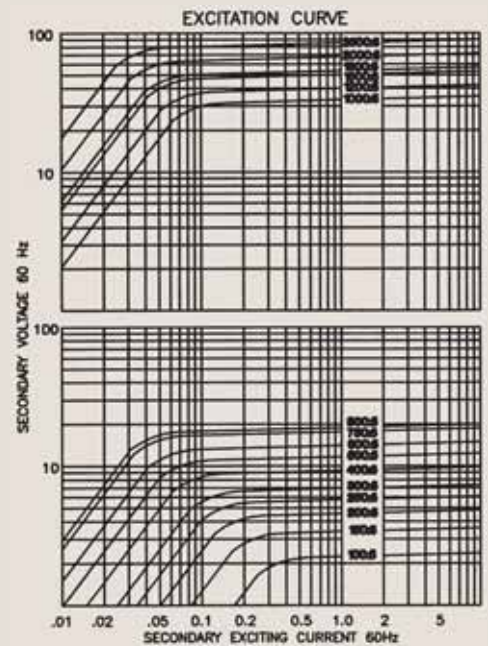

Application:

3 phase relay, metering and motor overload protection.

Frequency:

50 - 400Hz

Insulation Level:

- 600 Volts, 10kV BIL full wave
- Terminals are brass studs No. 8 - 32 with one flatwasher, lockwasher and regular nut
- Flexible leads UL 1015 105°C, CSA approved, #16AWG, 24" long are available
- Approximate weight: 7 lbs

Approvals



UL 257877

CSA 223647

Model 3P93

Window Diameter 2.88"

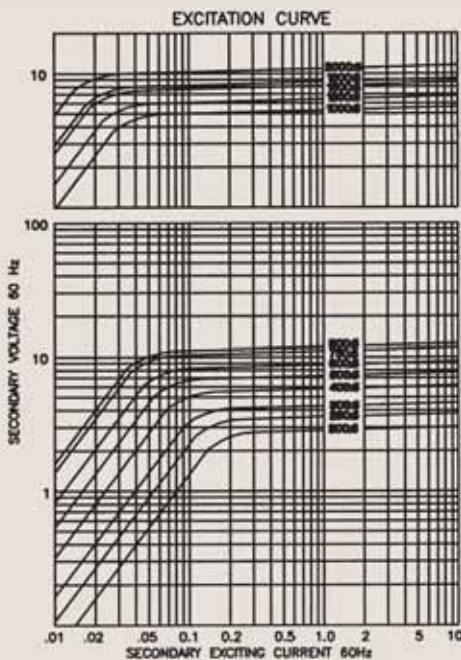
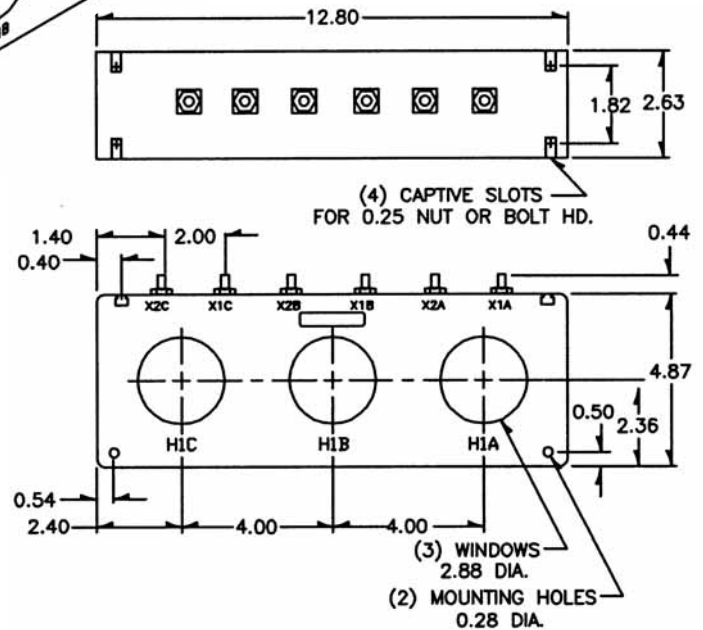
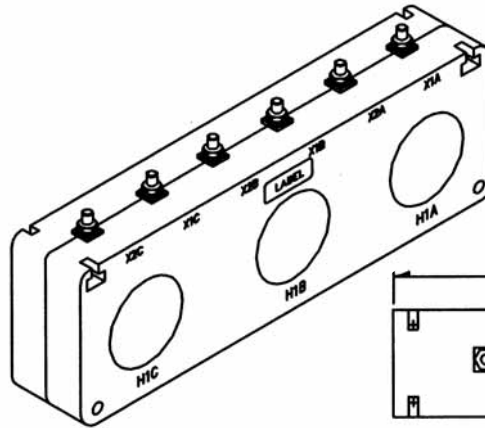

Catalogue Number	Current Ratio	V.A. for 1% Class	ANSI metering class at 60Hz					Secondary winding resistance (OHMS @ 75 °C)
			B0.1	B0.2	B0.5	B0.9	B1.8	
3P93-201	200:5	2.5	1.2	2.4	4.8	-	-	0.036
3P93-251	250:5	5	0.6	1.2	2.4	4.8	-	0.044
3P93-301	300:5	7.5	0.6	1.2	2.4	4.8	-	0.053
3P93-401	400:5	10	0.6	0.6	1.2	2.4	-	0.071
3P93-501	500:5	15	0.6	0.6	1.2	2.4	-	0.089
3P93-601	600:5	20	0.6	0.6	1.2	2.4	2.4	0.107
3P93-751	750:5	30	0.3	0.3	0.6	1.2	1.2	0.133
3P93-801	800:5	40	0.3	0.3	0.6	0.6	1.2	0.142
3P93-102	1000:5	20	0.3	0.3	0.6	1.2	-	0.127
3P93-122	1200:5	25	0.3	0.6	0.6	0.6	-	0.152
3P93-152	1500:5	30	0.3	0.3	0.3	0.6	-	0.190
3P93-162	1600:5	35	0.3	0.3	0.3	0.6	-	0.203
3P93-202	2000:5	40	0.3	0.3	0.3	0.3	0.6	0.254

NOTE: Captive slots on top of transformer case can be used for attaching auxiliary device mounting plate (not supplied).

If the application requires transformer mounted relays, etc., then transformer can be ordered with secondary leads configured in various ways (consult factory).

Specific Mounting (Breaker Type) Current Transformers

For Metering and Relaying

600V Current Transformers
ANSI Rated Specific Mount
Window Type

Contents				Page
Window Size		Model	Body Sizes	
1.25		196	W 4.54 H 5.36 D 2.19	92
3.12		197	W 4.54 H 5.36 D 2.19	93
7.62		682	W 13.50 H 13.50 D 3.00	94
6.50		780	W 9.88 H 9.88 D 3.38	95
6.50		781	W 9.88 H 9.88 D 3.38	96-97
6.50		785	W 9.88 H 9.88 D 6.75	98-99
6.50		786	W 9.88 H 9.88 D 6.75	100-101
6.50		778	W 9.88 H 9.88 D 1.50	102

Application:
Relaying and metering

Frequency:
50 - 400Hz

Insulation Level:
600 Volts, 10kV BIL full wave

Continuous Thermal Current Rating Factor:
1.33 at 30°C amb., 1.0 at 55°C amb.
 • Secondary terminals are No. 8 - 32 brass studs with one flatwasher, lockwasher and regular nut
 • Approximate weight: 6 lbs

Approvals



Model 196

Window Diameter 1.25"

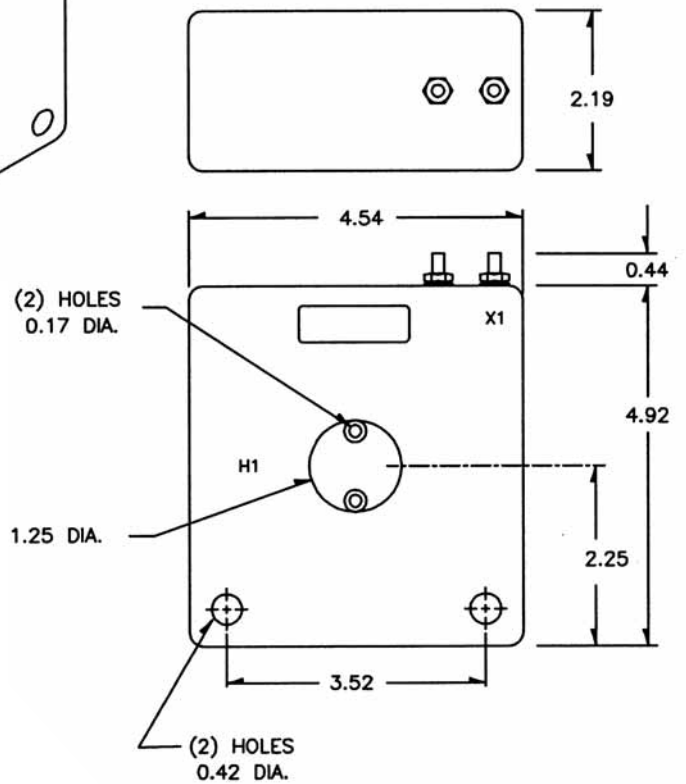
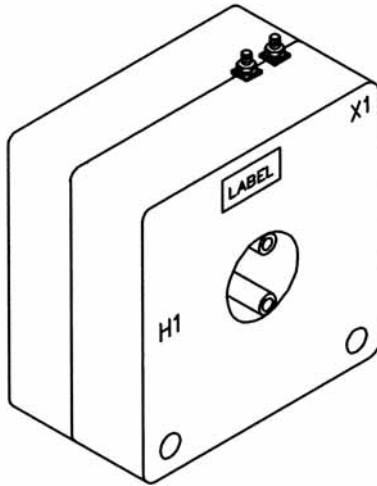

EXCITATION CURVE

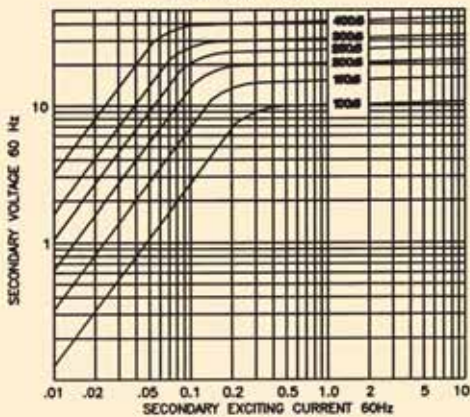

Catalogue Number	Current Ratio	Relay Class	ANSI metering class at 60Hz					Secondary winding resistance (OHMS @ 75°C)
			B0.1	B0.2	B0.5	B0.9	B1.8	
196-101	100:5	-	0.6	1.2	-	-	-	0.037
196-151	150:5	C10	0.3	0.6	1.2	-	-	0.056
196-201	200:5	C10	0.3	0.3	0.6	1.2	2.4	0.075
196-251	250:5	C20	0.3	0.3	0.6	0.6	1.2	0.094
196-301	300:5	C20	0.3	0.3	0.3	0.6	0.6	0.112
196-401	400:5	C20	0.3	0.3	0.3	0.3	0.6	0.150

Model 197

Window Diameter 3.12"

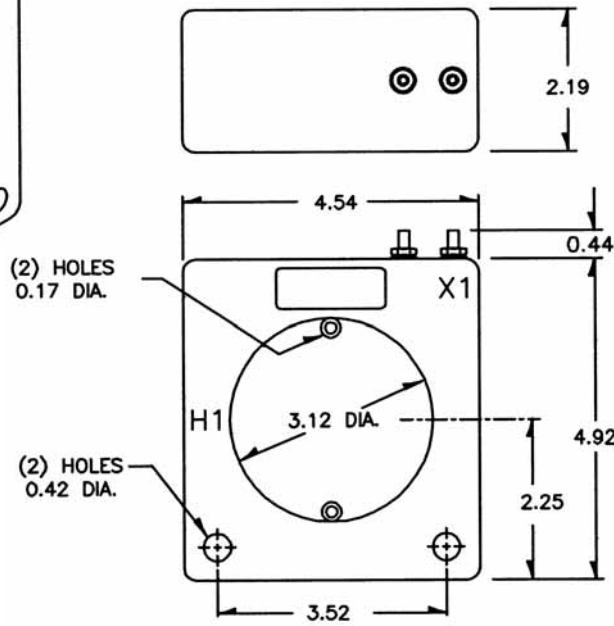
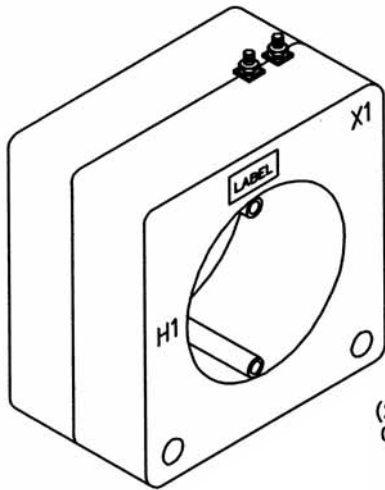

Catalogue Number	Current Ratio	ANSI metering class at 60Hz					Secondary winding resistance (OHMS @ 75°C)
		B0.1	B0.2	B0.5	B0.9	B1.8	
197-401	400:5	0.3	0.3	0.6	1.2	-	0.113
197-501	500:5	0.3	0.3	0.6	0.6	-	0.141
197-601	600:5	0.3	0.3	0.3	0.6	1.2	0.155
197-751	750:5	0.3	0.3	0.3	0.6	1.2	0.248
197-801	800:5	0.3	0.3	0.3	0.6	1.2	0.265
197-102	1000:5	0.3	0.3	0.3	0.3	1.2	0.331
197-122	1200:5	0.3	0.3	0.3	0.6	1.2	0.315
197-152	1500:5	0.3	0.3	0.3	0.3	1.2	0.471
197-162	1600:5	0.3	0.3	0.3	0.3	0.6	0.502
197-202	2000:5	0.3	0.3	0.3	0.3	0.6	0.782

MOUNTING ARRANGEMENT FOR MODEL 197 C.T.'S.

For use with WESTINGHOUSE moulded case circuit breakers. Generally two Current Transformers are used which fit on the two outer phase buses of the LA 600/LC 600, MA 600/MC 600, NB 1200/NC 1200 and TB-TC 2000/2500/3000 frame breakers.

The Current Transformer can be mounted directly to the busbars by means of small angle brackets. The 3/4 inch wide section of the Current Transformer permits it to be mounted between the 2 inch busbars which are on 2 3/4 inch centres. If a third Current Transformer is required, the centre phase bus is offset to the back.

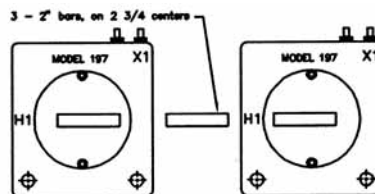

Application:
Metering

Frequency:
50 - 400Hz:

Insulation Level:
600 Volts, 10kV BIL full wave

Continuous Thermal Current Rating Factor:
1.33 at 30°C amb., 1.0 at 55°C amb.
 • Secondary terminals are No. 8 - 32 brass studs with one flatwasher, lockwasher and regular nut
 • Approximate weight: 2 lbs

Approvals

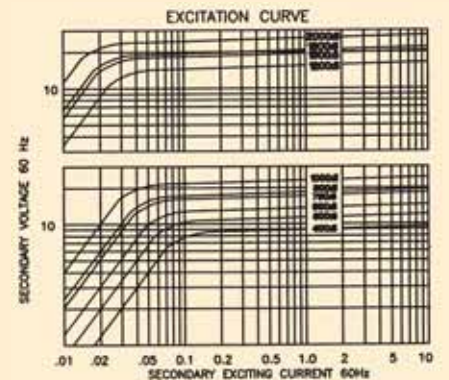

MOUNTING ARRANGEMENT FOR MODEL 197 C.T.'S.

Application:
Relaying and metering

Frequency:
50 - 400Hz

Insulation Level:
600 Volts, 10kV BIL full wave

Continuous Thermal Current Rating Factor:
50:5 thru 2000:5, 2.0 at 30°C amb.,
1.5 at 55°C amb.
2500:5 thru 3500:5, 1.33 at 30°C amb.,
1.0 at 55°C amb.
4000:5, 1.0 at 30°C amb., 0.75 at 55°C amb.

- Secondary terminals are No. 10 - 32 brass screws with one flatwasher, lockwasher and regular nut
- Multi-ratios available upon request
- Approximate weight: 30 lbs

Approvals



Model 682

Window Diameter 7.62"

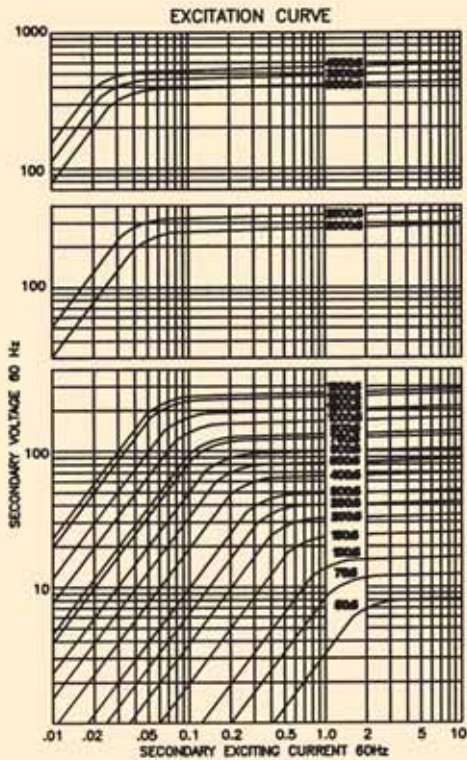
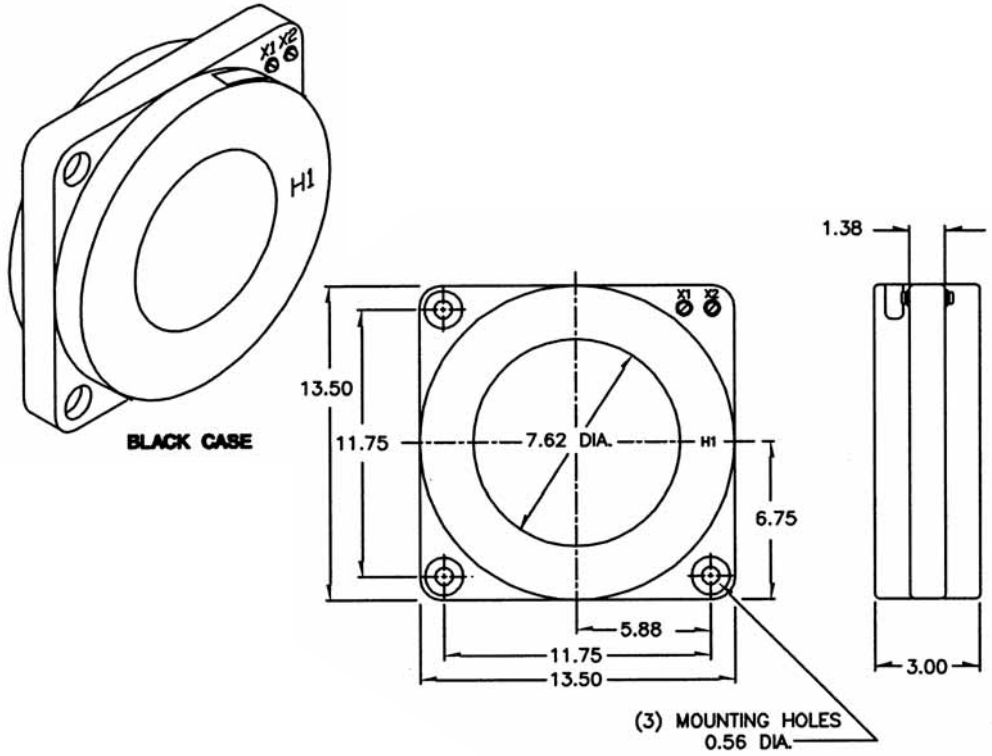

Catalogue Number	Current Ratio	ANSI Relay Class	ANSI metering class at 60Hz					D.C.R. @ 75°C
			B0.1	B0.2	B0.5	B0.9	B1.8	
682-500	50:5	C5	4.8	-	-	-	-	0.014
682-750	75:5	C10	2.4	4.8	-	-	-	0.020
682-101	100:5	C10	2.4	4.8	-	-	-	0.027
682-151	150:5*	C20	0.6	1.2	2.4	-	-	0.044
682-201	200:5*	C25	0.6	1.2	2.4	-	-	0.071
682-251	250:5*	C35	0.6	0.6	1.2	2.4	-	0.089
682-301	300:5*	C40	0.6	0.6	1.2	1.2	2.4	0.106
682-351	350:5*	C55	0.3	0.6	0.6	1.2	2.4	0.124
682-401	400:5*	C60	0.3	0.6	0.6	1.2	1.2	0.142
682-501	500:5*	C75	0.3	0.3	0.3	0.6	1.2	0.177
682-601	600:5*	C100	0.3	0.3	0.3	0.6	1.2	0.212
682-751	750:5*	C100	0.3	0.3	0.3	0.6	0.6	0.266
682-801	800:5*	C130	0.3	0.3	0.3	0.6	0.6	0.283
682-102	1000:5*	C170	0.3	0.3	0.3	0.3	0.3	0.354
682-122	1200:5*	C200	0.3	0.3	0.3	0.3	0.3	0.425
682-152	1500:5*	C200	0.3	0.3	0.3	0.3	0.3	0.531
682-162	1600:5*	C200	0.3	0.3	0.3	0.3	0.3	0.567
682-202	2000:5*	C210	0.3	0.3	0.3	0.3	0.3	0.648
682-252	2500:5*	C300	0.3	0.3	0.3	0.3	0.3	0.810
682-302	3000:5*	C300	0.3	0.3	0.3	0.3	0.3	0.938
682-352	3500:5*	C300	0.3	0.3	0.3	0.3	0.3	1.371
682-402	4000:5*	C300	0.3	0.3	0.3	0.3	0.3	1.962

Model 780

Window Diameter 6.5"

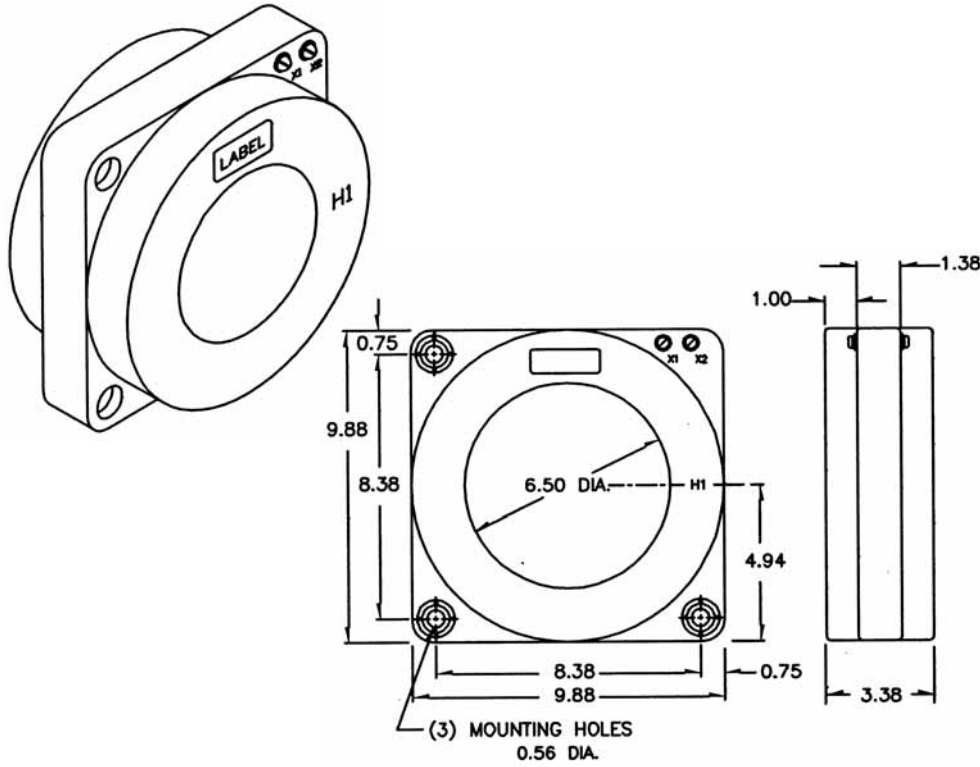

Catalogue Number	Current Ratio	Relay Class	ANSI metering class at 60Hz					D.C.R. @ 75°C
			B0.1	B0.2	B0.5	B0.9	B1.8	
780-500	50:5	-	4.8	-	-	-	-	0.008
780-750	75:5	C10	4.8	4.8	-	-	-	0.016
780-101	100:5	C10	1.2	1.2	4.8	-	-	0.027
780-151	150:5*	C20	0.6	0.6	2.4	2.4	4.8	0.042
780-201	200:5*	C20	0.6	0.6	1.2	2.4	4.8	0.054
780-251	250:5*	C20	0.6	0.6	0.6	1.2	2.4	0.067
780-301	300:5*	C20	0.3	0.6	0.6	1.2	2.4	0.097
780-401	400:5*	C50	0.3	0.3	0.3	0.6	1.2	0.129
780-501	500:5*	C50	0.3	0.3	0.3	0.6	0.6	0.161
780-601	600:5*	C100	0.3	0.3	0.3	0.3	0.6	0.193
780-751	750:5*	C100	0.3	0.3	0.3	0.3	0.3	0.242
780-801	800:5*	C100	0.3	0.3	0.3	0.3	0.3	0.258
780-102	1000:5*	C100	0.3	0.3	0.3	0.3	0.3	0.322
780-122	1200:5*	C200	0.3	0.3	0.3	0.3	0.3	0.387
780-152	1500:5*	C200	0.3	0.3	0.3	0.3	0.3	0.608
780-162	1600:5*	C200	0.3	0.3	0.3	0.3	0.3	0.649
780-202	2000:5*	C200	0.3	0.3	0.3	0.3	0.3	0.588
780-252	2500:5*	C200	0.3	0.3	0.3	0.3	0.3	0.735
780-302	3000:5*	C200	0.3	0.3	0.3	0.3	0.3	1.105
780-322	3200:5*	C100	0.3	0.3	0.3	0.3	0.3	0.859
780-352	3500:5*	C100	0.3	0.3	0.3	0.3	0.3	0.940
780-402	4000:5*	C200	0.3	0.3	0.3	0.3	0.3	1.074

Application:
Relaying and metering

Frequency:
50 - 400Hz:

Insulation Level:
600 Volts, 10kV BIL full wave

Continuous Thermal Current Rating Factor:
50:5 thru 1200:5, 2.0 at 30°C amb.,
1.5 at 55°C amb.
1500:5 thru 4000:5, 1.5 at 30°C amb.,
1.33 at 55°C amb.

- Secondary terminals are No. 10 - 32 brass screws with one flatwasher, lockwasher and regular nut
- Approximate weight: 30 lbs

Approvals

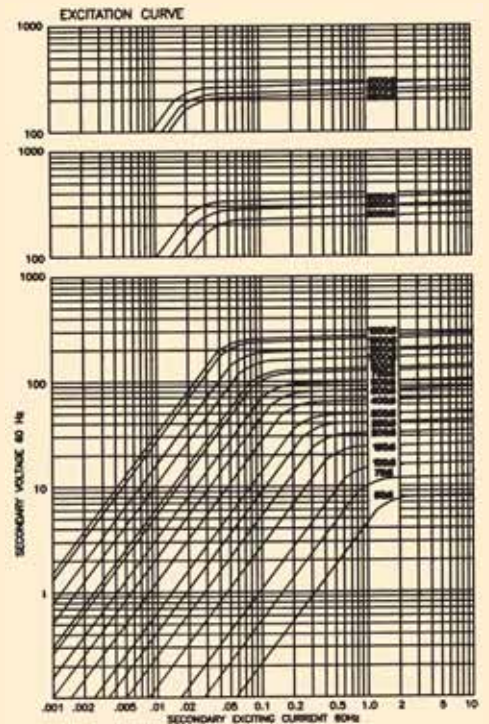

Application:
Relaying and metering

Frequency:
50 - 400Hz

Insulation Level:
600 Volts, 10kV BIL full wave

Continuous Thermal Current Rating Factor:
2.0 at 30°C amb., 1.5 at 55°C amb.
 • Secondary terminals are No. 10 - 32 brass screws with one flatwasher, lockwasher and regular nut
 • Approximate weight: 31 lbs

Approvals

UL 257877
CSA 223647

Model 781

Window Diameter 6.5"

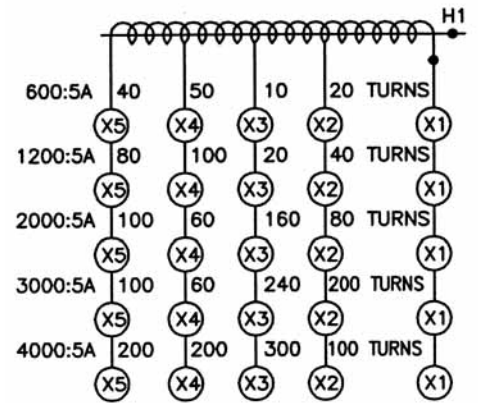
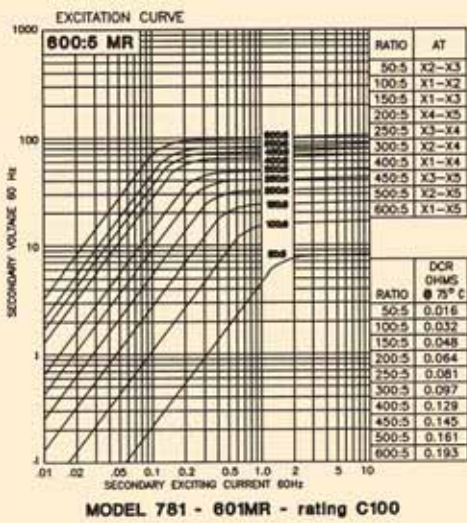
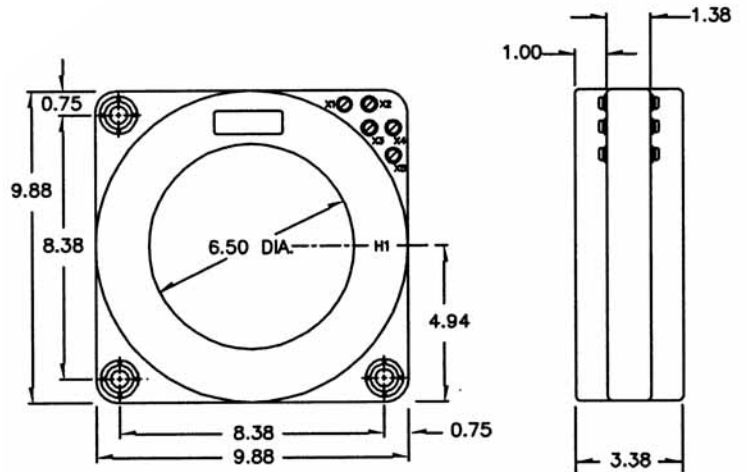
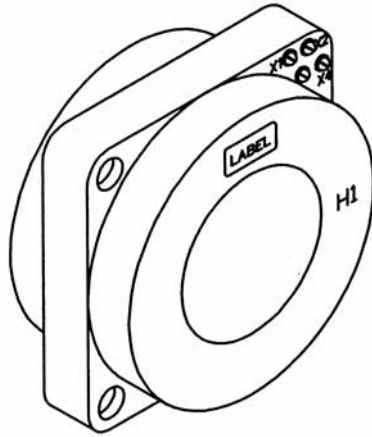

CONNECTION DIAGRAM

Typical Excitation Curves - Model 781

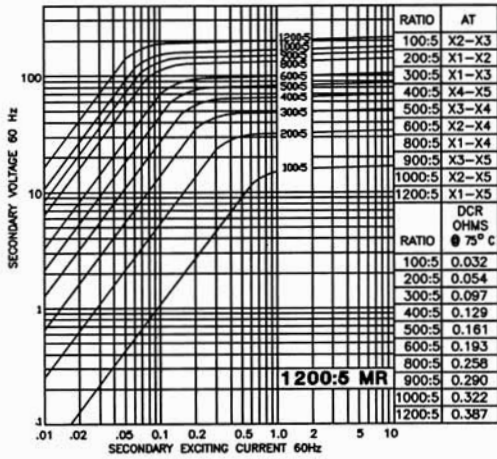

MODEL 781 - 122MR - rating C200

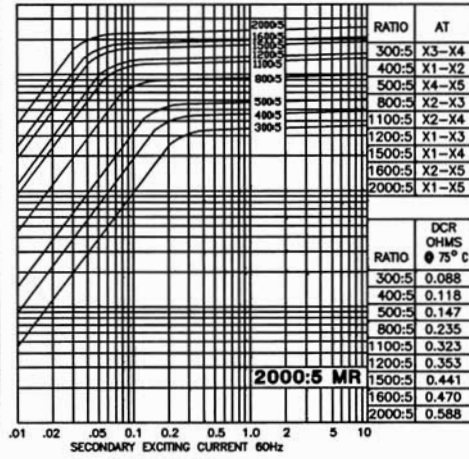

MODEL 781 - 202MR - rating C200

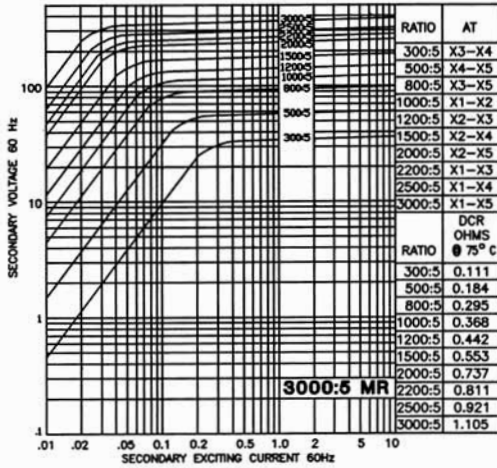

MODEL 781 - 302MR - rating C200

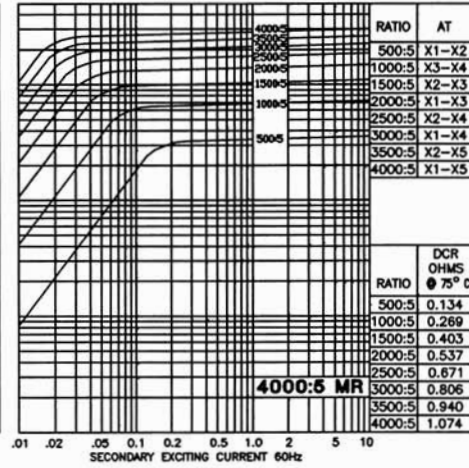

MODEL 781 - 402MR - rating C200

Application:
Relaying and metering

Frequency:
50 - 400Hz

Insulation Level:
600 Volts, 10kV BIL full wave

Continuous Thermal Current Rating Factor:
50:5 thru 1200:5, 2.0 at 30°C amb.,
1.5 at 55°C amb.
1500:5 thru 2500:5, 1.5 at 30°C amb.,
1.33 at 55°C amb.
3000:5 thru 4000:5, 1.33 at 30°C amb.,
1.0 at 55°C amb.

- Secondary terminals are No. 10 - 32 brass screws with one flatwasher, lockwasher and regular nut
- Approximate weight: 58 lbs

Approvals



CSA 223647

Model 785

Window Diameter 6.5"

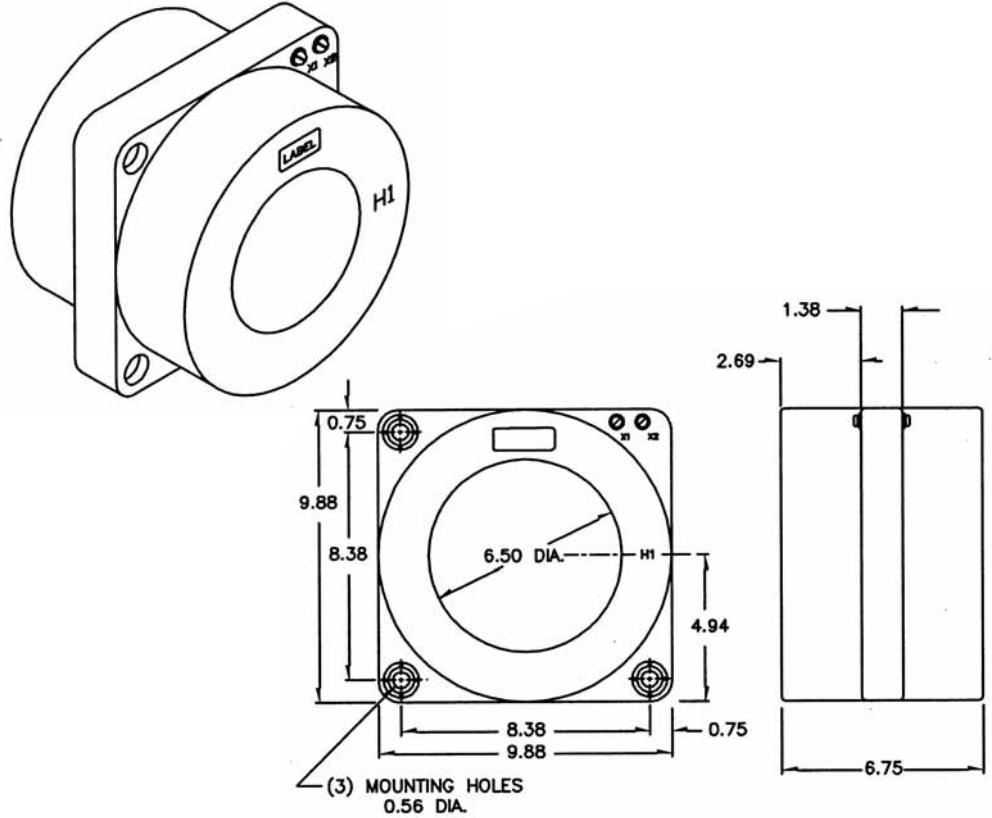

Catalogue Number	Current Ratio	Relay Class	ANSI metering class at 60Hz				
			B0.1	B0.2	B0.5	B0.9	B1.8
785-500	50:5	C10	2.4	4.8	-	-	-
785-750	75:5	C20	1.2	1.2	2.4	-	-
785-101	100:5*	C20	0.6	1.2	2.4	-	-
785-151	150:5*	C50	0.6	0.6	1.2	2.4	-
785-201	200:5*	C50	0.3	0.3	0.6	1.2	2.4
785-251	250:5*	C50	0.3	0.3	0.6	1.2	2.4
785-301	300:5*	C100	0.3	0.3	0.3	0.6	1.2
785-401	400:5*	C100	0.3	0.3	0.3	0.6	1.2
785-501	500:5*	C100	0.3	0.3	0.3	0.3	0.6
785-601	600:5*	C200	0.3	0.3	0.3	0.3	0.6
785-751	750:5*	C200	0.3	0.3	0.3	0.3	0.3
785-801	800:5*	C200	0.3	0.3	0.3	0.3	0.3
785-102	1000:5*	C200	0.3	0.3	0.3	0.3	0.3
785-122	1200:5*	C400	0.3	0.3	0.3	0.3	0.3
785-152	1500:5*	C400	0.3	0.3	0.3	0.3	0.3
785-162	1600:5*	C400	0.3	0.3	0.3	0.3	0.3
785-202	2000:5*	C400	0.3	0.3	0.3	0.3	0.3
785-252	2500:5*	C400	0.3	0.3	0.3	0.3	0.3
785-302	3000:5*	C400	0.3	0.3	0.3	0.3	0.3
785-402	3200:5*	C400	0.3	0.3	0.3	0.3	0.3

Typical Excitation Curves - Model 785

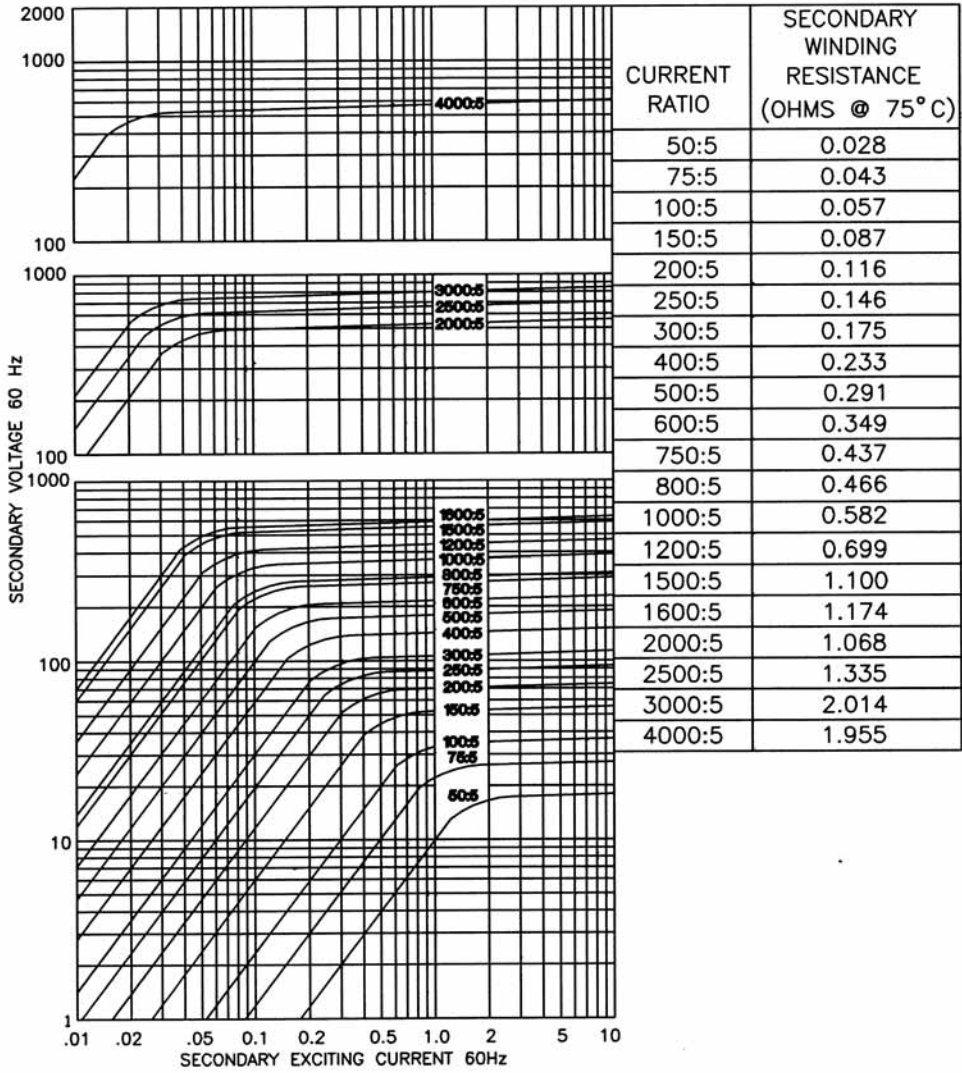

Application:
Relaying and metering

Frequency:
50 - 400Hz

Insulation Level:
600 Volts, 10kV BIL full wave

Continuous Thermal Current Rating Factor:
2.9 at 30°C amb., 1.5 at 55°C amb.
• Secondary terminals are No. 10 - 32 brass screws with one flatwasher, lockwasher and regular nut
• Approximate weight: 58 lbs

Approvals

UL 257877
CSA 223647

Model 786

Window Diameter 6.5"

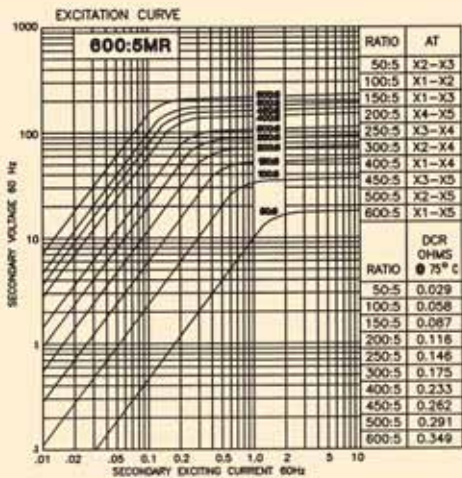
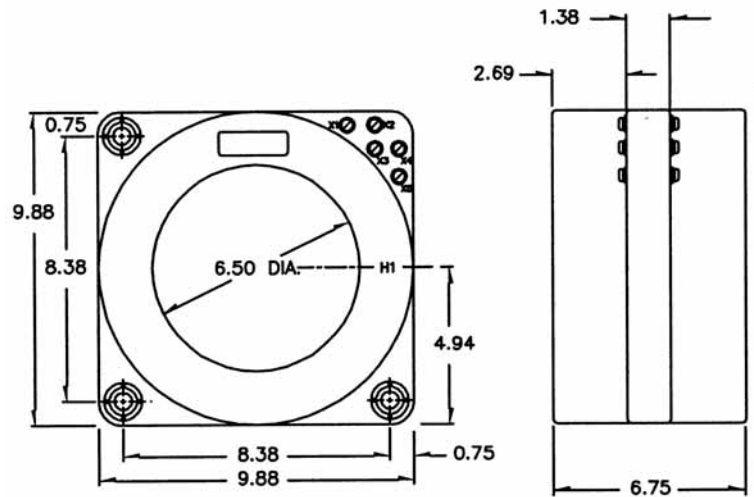
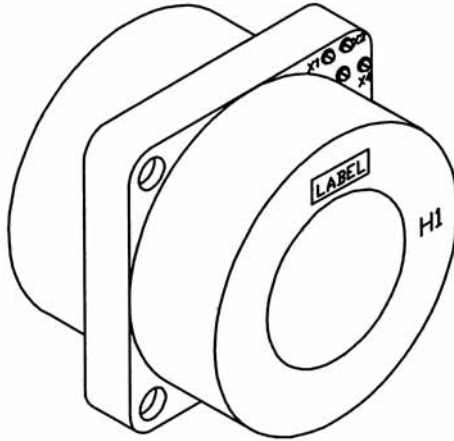

MODEL 786 - 601MR - rating C200

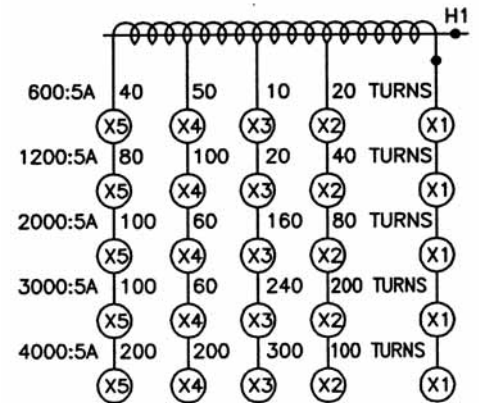

CONNECTION DIAGRAM

Typical Excitation Curves - Model 786

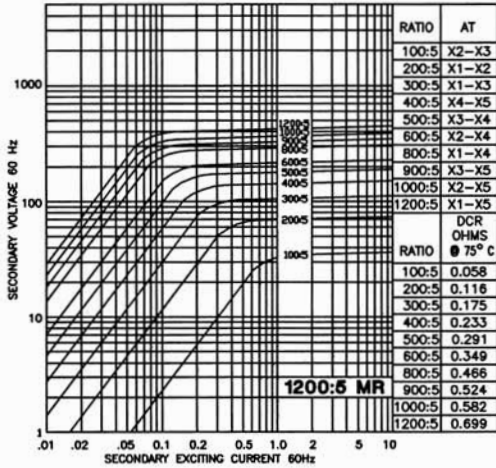

MODEL 786 - 122MR - rating C400

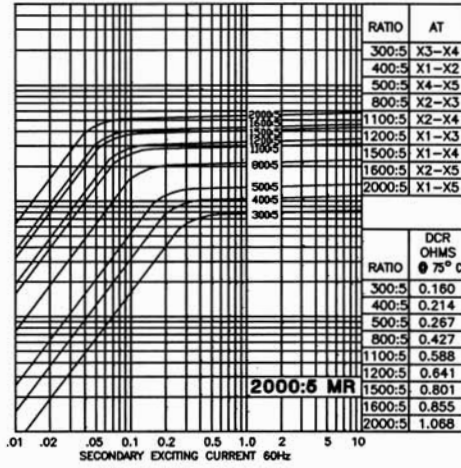

MODEL 786 - 202MR - rating C400

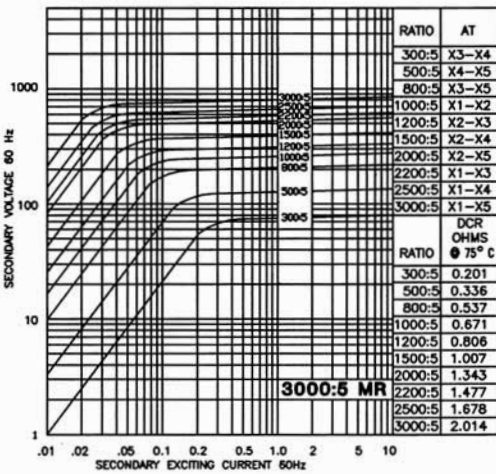

MODEL 786 - 302MR - rating C400

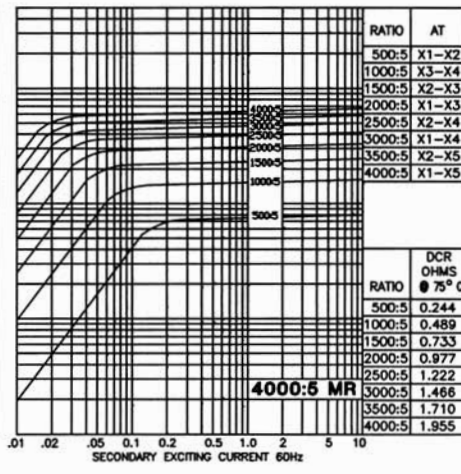

MODEL 788 - 402MR - rating C400

Application:
Relaying and metering

Frequency:
50 - 400Hz

Insulation Level:
600 Volts, 10kV BIL full wave

Continuous Thermal Current Rating Factor:
1.33 at 30°C amb., 1.0 at 55°C amb.
• Secondary terminals are No. 10 - 32 brass screws with one flatwasher, lockwasher and regular nut
• Approximate weight: 15 lbs

Approvals



Model 778

Window Diameter 6.5"

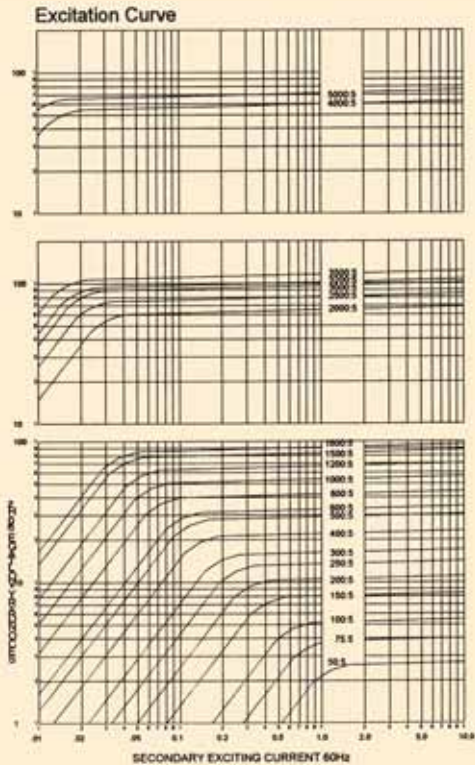
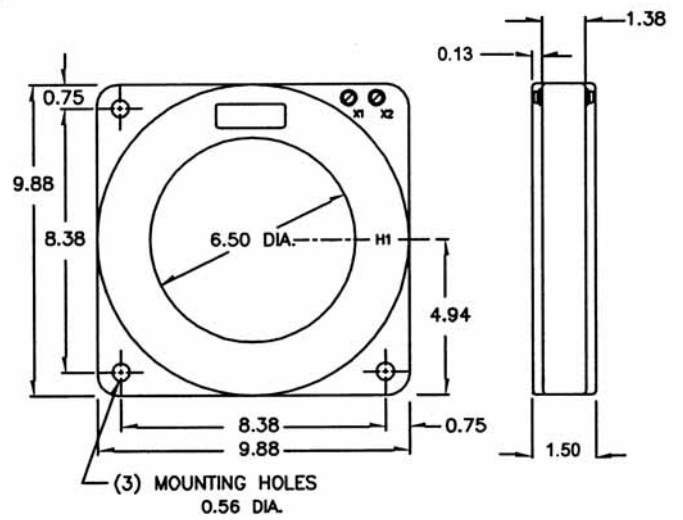
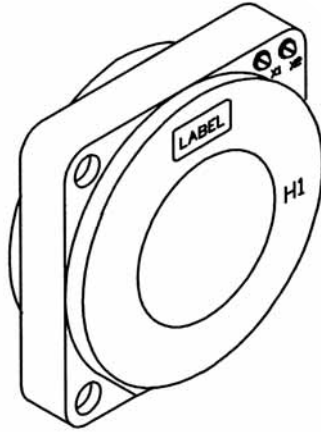

Catalogue Number	Current Ratio	Relay Class	ANSI metering class at 60Hz					Secondary winding resistance (OHMS @ 75°C)
			B0.1	B0.2	B0.5	B0.9	B1.8	
778-500	50:5	-	-	-	-	-	-	0.010
778-750	75:5	-	4.8	-	-	-	-	0.016
778-101	100:5	-	1.2	4.8	-	-	-	0.021
778-151	150:5	-	0.6	1.2	4.8	-	-	0.032
778-201	200:5	C10	0.3	0.6	2.4	4.8	-	0.043
778-251	250:5	C10	0.3	0.6	1.2	2.4	-	0.053
778-301	300:5	C10	0.3	0.3	1.2	2.4	4.8	0.064
778-401	400:5	C20	0.3	0.3	0.6	1.2	2.4	0.086
778-501	500:5	C20	0.3	0.3	0.3	0.6	1.2	0.107
778-601	600:5	C20	0.3	0.3	0.3	0.3	1.2	0.128
778-801	800:5	C20	0.3	0.3	0.3	0.3	0.6	0.171
778-102	1000:5	C50	0.3	0.3	0.3	0.3	0.3	0.214
778-122	1200:5	C50	0.3	0.3	0.3	0.3	0.3	0.263
778-152	1500:5	C100	0.3	0.3	0.3	0.3	0.3	0.328
778-162	1600:5	C100	0.3	0.3	0.3	0.3	0.3	0.350
778-202	2000:5	C50	0.3	0.3	0.3	0.3	0.3	0.473
778-252	2500:5	C50	0.3	0.3	0.3	0.3	0.3	0.592
778-302	3000:5	C100	0.3	0.3	0.3	0.3	0.3	0.710
778-322	3200:5	C100	0.3	0.3	0.3	0.3	0.3	0.757
778-352	3500:5	C100	0.3	0.3	0.3	0.3	0.3	0.828
778-402	4000:5	C20	0.3	0.3	0.3	0.3	0.3	0.719
778-502	5000:5	C20	0.3	0.3	0.3	0.3	0.3	0.898

Wound Primary Current Transformers

Auxiliary Transformers

600V Auxiliary
Current Transformers
ANSI Rated
Wound Primary Type

Contents Page

Model Number	Overall Size			Page
	Width	Height	Depth	

20	4.59	x	5.57	x	3.00	104
----	------	---	------	---	------	-----



190	4.50	x	5.32	x	2.19	105
-----	------	---	------	---	------	-----



189	2.70	x	3.19	x	4.10	106
-----	------	---	------	---	------	-----



188	5.25	x	5.25	x	5.25	107
-----	------	---	------	---	------	-----





Model 20 - Wound Primary

Model 20X - Auxiliary Transformer

MODEL 20

The Model 20 is a low ratio wound primary current transformer, suitable for primary currents up to 50 amperes. It is rated for metering and relaying applications. The table below lists the most common current ratings. Other ratios are available.

Catalogue Number	VA for 1% Class	Relay Class	ANSI metering class at 60Hz				
			B0.1	B0.2	B0.5	B0.9	B1.8
20-2-XXX	25.0	T10	0.3	0.3	0.6	1.2	2.4
20-4-XXX	125	T20	0.3	0.3	0.3	0.3	0.3

RATIO	1:5	2.5:5	5:5	7.5:5	10:5	15:5	20:5	25:5	30:5	40:5	50:5
SUFFIX	001	0025	005	0075	010	015	020	025	030	040	050

* ¼ - 20 stud terminals

MODEL 20X

ANSI Metering Class: 0.3 B1.8

The Model 20X is an auxiliary transformer for use in the secondary of main current transformers to change the ratio for metering applications.

Since the Model 20X is used in the secondary of another current transformer it has no voltage rating. It is given a 2500 Volt 60Hz high potential test. It is designed to be used on circuits not to exceed 600 Volts to ground or between windings.

Catalogue Number	Current Ratio
20X0100	5:0.100
20X0200	5:0.200
20X0250	5:0.250
20X0500	5:0.500
20X0625	5:0.625
20X1000	5:1.000
20X1250	5:1.250
20X1667	5:1.667
20X2000	5:2.000
20X2395	5:2.395
20X2500	5:2.500
20X2890	5:2.890
20X3000	5:3.000
20X3330	5:3.330
20X3750	5:3.750
20X4000	5:4.000
20X5000	5:5.000
20X5330	5:5.330

Catalogue Number	Current Ratio
190X6250	5:6.250
190X7500	5:7.500
190X8000	5:8.000
190X10000	5:10.000
190X12500	5:12.500
190X15000	5:15.000
190X1500-5	1.500:5
190X1667-5	1.667:5
190X2500-5	2.500:5
190X2875-5	2.875:5
190X7500-5	7.500:5
190X10500-5	10.500:5
190X0500-1	0.500:1
190X0923-1	0.923:1
190X0400-10	0.400:10
190XSUM-2**	5+5:5
190XSUM-3**	5+5+5:5
190XSUM-4**	5+5+5+5:5
190XSUM-5**	5+5+5+5+5:5

** The circuits of up to five secondaries may be totalised. Equal or unequal line current transformers can be summed with this transformer. Advise the ratios of the line current transformers to be totalised. Output terminals are X1-X2.

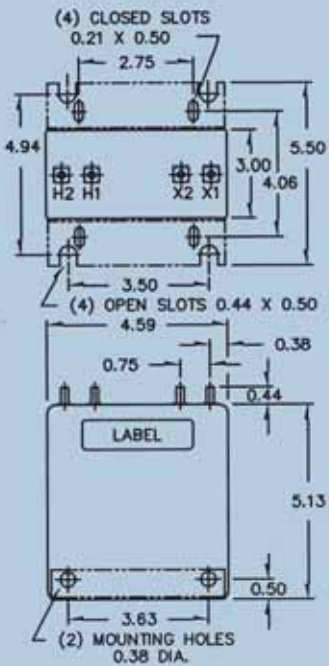

Insulation Level Model 20 Wound Primary:

0.6kV BIL 10kV full wave

Continuous Thermal Current Rating Factor:

1.33 at 30°C amb., 1.0 at 55°C amb.

- Terminals are brass studs No. 8 - 32 with one flatwasher, lockwasher and regular nut, for ratios up to 25:5 and 1/4 - 20 studs for higher ratios
- Order Mounting Bracket Kit
- Approximate weight: 8 lbs

Approvals



UL 257877

CSA 223647

Model 109 – Wound Primary

Model 190X – Auxiliary Transformer

MODEL 190

The Model 190 is a low ratio wound primary current transformer, suitable for primary currents up to 50 amperes. The table below lists the most common current ratings.

Catalogue Number	VA for 1% Class	ANSI metering class at 60Hz				
		B0.1	B0.2	B0.5	B0.9	B1.8
190-2-XXX	12.5	0.6	0.6	1.2	2.4	-
190-4-XXX	30.0	0.3	0.3	0.3	0.6	1.2

* $\frac{1}{4}$ – 20 stud terminals

MODEL 190X

ANSI Metering Class: 0.3 B0.5

The Model 190X is an auxiliary transformer for use in the secondary of main current transformers to change the ratio for metering applications. Since the Model 190X is used in the secondary of another current transformer it has no voltage rating. It is given a 2500 Volt 60Hz high potential test. It is designed to be used on circuits not to exceed 600 Volts to ground or between windings.

Catalogue Number	Current Ratio
190X0100	5:0.100
190X0200	5:0.200
190X0250	5:0.250
190X0500	5:0.500
190X0625	5:0.625
190X1000	5:1.000
190X1250	5:1.250
190X1667	5:1.667
190X2000	5:2.000
190X2395	5:2.395
190X2500	5:2.500
190X2890	5:2.890
190X3000	5:3.000
190X3330	5:3.330
190X3750	5:3.750
190X4000	5:4.000
190X5000	5:5.000
190X5333	5:5.330

Catalogue Number	Current Ratio
190X6250	5:6.250
190X7500	5:7.500
190X8000	5:8.000
190X10000	5:10.000
190X12500	5:12.500
190X15000	5:15.000
190X1500-5	1.500:5
190X1667-5	1.667:5
190X2500-5	2.500:5
190X2875-5	2.875:5
190X7500-5	7.500:5
190X10500-5	10.500:5
190X0500-1	0.500:1
190X0923-1	0.923:1
190X0400-10	0.400:10
190XSUM-2**	5+5:5
190XSUM-3**	5+5+5:5
190XSUM-4**	5+5+5+5:5
190XSUM-5**	5+5+5+5+5:5

** The circuits of up to five secondaries may be totalised. Equal or unequal line current transformers can be summed with this transformer. Advise the ratios of the line current transformers to be totalised. Output terminals are X1-X2.

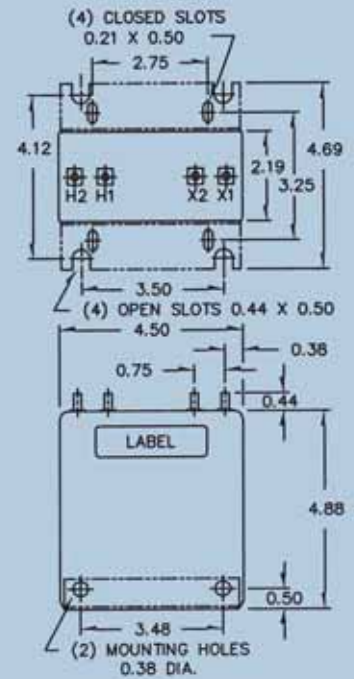

Frequency:

5 – 400Hz

Insulation Level

600 Volts, 10kV BIL full wave

Continuous Thermal Current

Rating Factor:

1.33 at 30°C amb., 1.0 at 55°C amb.

- Terminals are brass studs No. 8 – 32 with one flatwasher and regular nut, for ratios upto 25:5 and $\frac{1}{4}$ – 20 studs for higher ratios
- Order Mounting Bracket Kit
- Approximate weight: 4 lbs

Approvals



UL 257877

CSA 223647



MODEL 189

Model 189 – Wound Primary

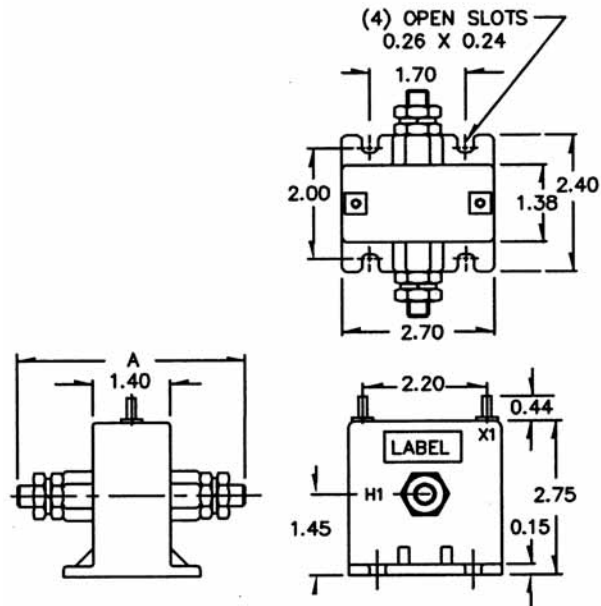

The Model 189 is a low ratio wound primary current transformer, suitable for primary currents up to 100 amperes. The table below lists the most common current ratings. Primary terminals for the Model 189 for ratios of 30:5 and below are No.10-32 brass screws with one lockwasher (Dimension A=3.28), for ratios 40:5 and above, 3/8-16 brass studs with one lockwasher and regular nut (Dimension A=4.10).

Application:

Ammeters and wallmeters

Frequency:

50 - 400Hz

Insulation Level:

0.6 kV, BIL 10kV full wave

Continuous Thermal Current Rating Factor:

1.33 at 30°C amb., 1.0 at 55°C amb.

- Secondary terminals are brass studs No. 8 - 32 UNC with one flatwasher, lockwasher and regular nut
- Approximate weight: 0.75 lbs

Approvals



Catalogue Number	Current Ratio	ANSI metering class at 60Hz	
		B0.1	B0.2
189-0025	2.5:5	0.6	0.6
189-005	5:5	0.6	0.6
189-0075	7.5:5	0.6	0.6
189-010	10:5	0.6	0.6
189-015	15:5	0.6	0.6
189-020	20:5	0.6	0.6
189-025	25:5	0.6	0.6
189-030	30:5	0.6	0.6
189-040	40:5	0.6	0.6
189-050	50:5	0.6	0.6
189-060	60:5	0.6	0.6
189-075	75:5	0.6	0.6
189-080	80:5	0.6	0.6
189-101	100:5	0.6	0.6

Model 188

Auxiliary Transformer

MODEL 190X

ANSI Metering Class: 0.3 B0.5

The Model 190X is an auxiliary transformer for use in the secondary of main current transformers to change the ratio for metering applications. Since the Model 190X is used in the secondary of another current transformer it has no voltage rating. It is given a 2500 Volt 60Hz high potential test. It is designed to be used on circuits not to exceed 600 Volts to ground or between windings.

Catalogue Number	Current Ratio
190X0100	5:0.100
190X0200	5:0.200
190X0250	5:0.250
190X0500	5:0.500
190X0625	5:0.625
190X1000	5:1.000
190X1250	5:1.250
190X1667	5:1.667
190X2000	5:2.000
190X2395	5:2.395
190X2500	5:2.500
190X2890	5:2.890
190X3000	5:3.000
190X3330	5:3.330
190X3750	5:3.750
190X4000	5:4.000
190X5000	5:5.000
190X5333	5:5.330

Catalogue Number	Current Ratio
190X6250	5:6.250
190X7500	5:7.500
190X8000	5:8.000
190X10000	5:10.000
190X12500	5:12.500
190X15000	5:15.000
190X1500-5	1.500:5
190X1667-5	1.667:5
190X2500-5	2.500:5
190X2875-5	2.875:5
190X7500-5	7.500:5
190X10500-5	10.500:5
190X0500-1	0.500:1
190X0923-1	0.923:1
190X0400-10	0.400:10
190XSUM-2**	5+5:5
190XSUM-3**	5+5+5:5
190XSUM-4**	5+5+5+5:5
190XSUM-5**	5+5+5+5+5:5

** The circuits of up to five secondaries may be totalised. Equal or unequal line current transformers can be summed with this transformer. Advise the ratios of the line current transformers to be totalised. Output terminals are X1-X2.

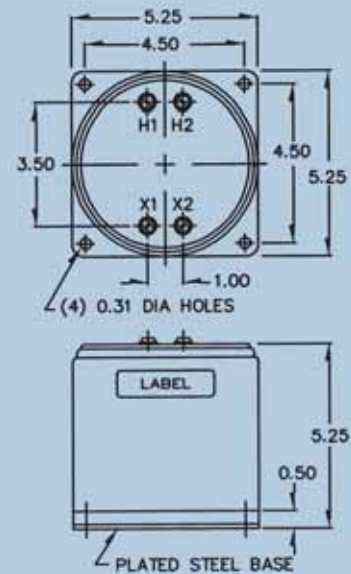
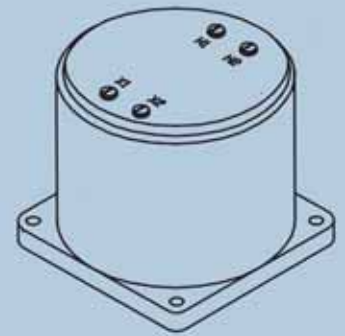

Application:

For use in the secondary of current transformers to change ratio for metering applications.

Frequency:

50 - 400Hz

Continuous Thermal Current Rating Factor:

- 1.5 at 30°C amb., 1.0 at 55°C amb.
- Terminals are No. 10 - 32 brass binding head screws
- Approximate weight: 10 lbs

Approvals



Voltage Transformers







600V Voltage Transformers
ANSI Rated

600 Volt Class

See back of this page for application data.
Review page 8 for circle diagram methods
for the estimation of voltage transformer
accuracy classes.

Contents

Page

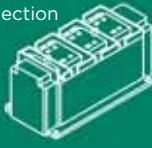
Model number	Accuracy class thermal rating	Overall Size Width x Height x Depth	Page
Single-phase			
467 	±1% @ 5VA 40VA @ 30 °C	3.00 x 3.63 x 3.50	112
468 	±0.6% @ 7.5VA 75VA @ 30 °C	3.63 x 4.06 x 2.81	113
460 	0.6% & 1.2X 150VA @ 30 °C	4.50 x 3.88 x 4.75	114
475 	0.3W, 0.6X & 1.2M 300VA @ 30 °C	4.38 x 4.63 x 4.75	115
450 	0.3W, X, M & Y, 1.2Z 750V @ 30 °C	6.00 x 7.50 x 6.50	116
Three-phase			
2VT469 	±1% @ 5VA 40VA per phase @ 30 °C	4.19 x 3.63 x 4.38	117
3VTN460 Line to neutral connection 	0.6W & 1.2X per phase 150VA per phase @30 °C	10.25 x 4.75 x 4.75	118
3VTL460 Line to line connection			119

Voltage Transformer Groups

GROUP 1

Transformers for application with 100% of rated primary voltage connected to the primary terminals either line-to-line or line-to-ground. These transformers are capable of operating at 125% of rated volts in emergency conditions, but cannot exceed 65% of their thermal burden rating, with a limit of 75°C temperature rise. This will result in a reduced life expectancy. Consult the factory for details. Continuous operation at 110% of rated voltage is permissible, provided that the thermal burden rating is not exceeded.

Primary Voltage Rating	Turns Ratio	B.I.L (Kv peak)
120 for 208Y	1:1	10
240 for 416Y	2:1	10
300 for 520Y	2.5:1	10

GROUP 2

Transformers are for line-to-line connection, but may be connected line-to-neutral at a voltage of the rated line volts divided by the square root of 3.

Continuous operation at 110% of rated voltage is permissible, provided that the thermal burden rated volt amperes is not exceeded.

Primary Voltage Rating	Turns Ratio	B.I.L (Kv peak)
120 for 208Y	1:1	10
240 for 416Y	2:1	10
300 for 520Y	2.5:1	10

Voltage Transformer Fuses

This Voltage Transformer section contains some models that can be fitted with primary fuses. The fuse style is the CC class having a rejection feature. These fuses are rated as current limiting with a 200,000 ampere (RMS symmetrical) interrupting rating, for BRANCH circuits of 600 Volts or less. The fuses are contained in a fuseblock that will accept only class CC, UL approved fuses. This prevents other fuse types of the same size being fitted that would have a lower interrupting capacity and/or a non-current limiting capability. It is possible to fit the fuse carrier and fuseblock to our models 450, 456 and 475 after manufacture so that a field retro-fit can be made.

The National Electric Code requires that all voltage transformers installed indoors or in an enclosure shall be fused in the primary circuit with devices rated 15 amperes or less. This arrangement will protect the supply from faults internally in the transformer, but faults in the secondary circuit may not rupture the primary fuse. It is suggested that the user fit secondary circuit fuses to protect the transformer from such faults. The recommended fuse rating is 125% of rated full load amperes, with a maximum of 167%, again referring to the National Electric Code.

When fusing either the primary or the secondary circuits of voltage transformers that are connected line-to-ground, only one fuse should be fitted line side so that the transformer cannot remain energised from a line connection while the grounded neutral fuse is ruptured. The selection of fuses as listed with each model that can accept fuses, is based upon magnetising inrush considerations and not necessarily upon the VA rating of the transformer. In cases where the user wishes to select and mount fuses elsewhere in equipment, we recommend that the ratings given be adhered to. If no fuses are listed, consult the factory engineers for a recommendation.

Voltage Transformer Burden Data

Burden	Volt Amperes	Power Factor	P.F. Angle
W	12.5	0.10	84.3°
X	25	0.70	45.6°
M	35	0.20	78.5°
Y	75	0.85	31.8°
Z	200	0.85	31.8°
ZZ	400	0.85	31.8°

Frequency:
50Hz

Standard Secondary Voltage:
120 Volts

Insulation Level:
600 Volts, 10kV BIL full wave

Accuracy Class:
31% at all burdens up to 5VA
at 1.0 and 0.95 P.F.
Thermal Rating:
40VA at 30°C amb
27VA at 55°C amb

Approvals



Model 467

- The core and coil assembly is encased in a thermoplastic shell and filled with resin.
- These transformers are designed for operation line-to-line. They may also be operated line-to-ground or line-to-neutral at reduced voltage, (58% of rated volts).
- Terminals are No. 6-32 screws with one lockwasher and one flatwasher.
- It is desirable to use a 0.40 amp fuse in the secondary to protect the transformer.
- With two exceptions these transformers are ANSI C57.13 group 1. Those marked * are group 2.
- Models designed specifically for 50Hz operation are available with reduced performance - consult factory for details.
- Each transformer has a clear plastic terminal cover.
- Approximate weight: 2.5 lbs

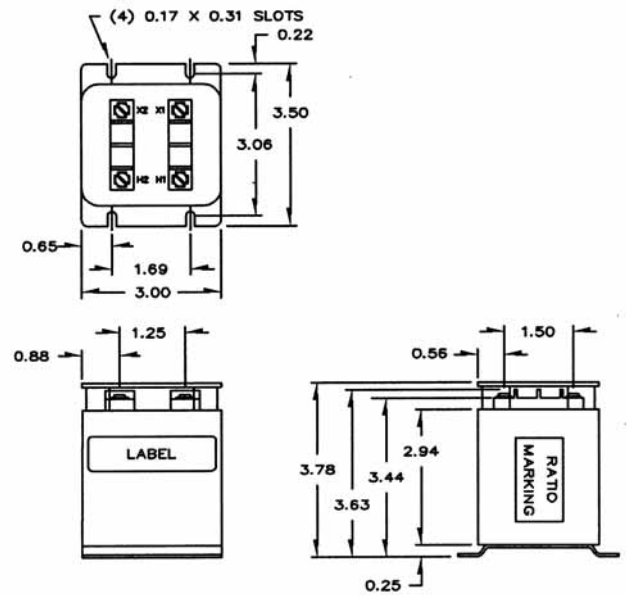
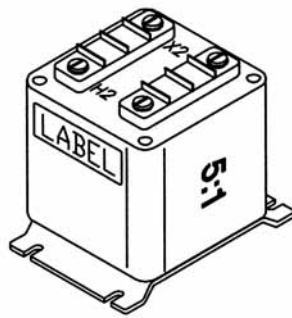

Catalogue Number	Voltage Rating	Turns Ratio	Rec. Primary Fuse Rating
467-069	69.3:120	0.58:1	1.5
467-120	120:120	1:1	1.0
467-208	208:120	1.73:1	0.5
467-240	240:120	2:1	0.5
467-277	277:120	2.31:1	0.5
467-288	288:120	2.4:1	0.4
467-300	300:120	2.5:1	0.4
467-346	346:120	2.88:1	0.4
*467-480	*480:120	4:1	0.25
*467-600	*600:120	5:1	0.25

Model 468

- Terminals are brass studs No. 10-32 with one lockwasher, flatwasher and regular nut.
- These transformers are designed for operation line-to-line. They may also be operated line-to-ground or line-to-neutral at reduced voltage, (58% of rated volts).
- It is desirable to use a 0.80 amp fuse in the secondary to protect the transformer.
- With two exceptions these transformers are ANSI C57.13 group 1.
Those marked * are group 2.
- Models 468-380, 468-400, 468-416 designed specifically for 50Hz operation are available with reduced performance - consult factory for details.
- Each transformer has two plastic terminal covers.
- The core and coil assembly is encased in a thermoplastic shell and filled with resin.
- Approximate weight: 4 lbs

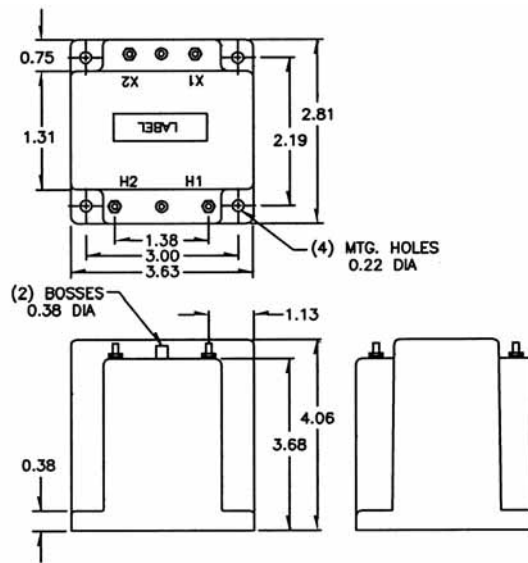
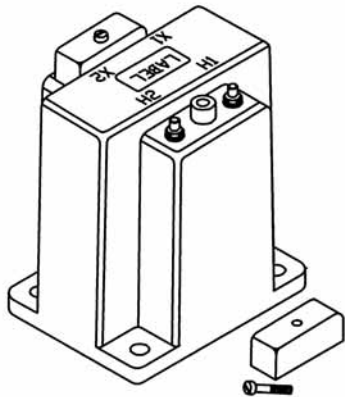

Frequency:
50Hz

Standard Secondary Voltage:
120 Volts

Insulation Level:
600 Volts, 10kV BIL full wave

Accuracy Class:
30.6 at all burdens up to 7.6VA
at 1.5% with 20VA burden.

Thermal Rating:
75VA at 30°C amb
50VA at 55°C amb

Approvals



Catalogue Number	Voltage Rating	Turns Ratio	Rec. Primary Fuse Rating
467-069	69.3:120	0.58:1	1.5
468-069	69.3:120	0.58:1	3.0
468-120	120:120	1:1	2.0
468-208	208:120	1.73:1	1.0
468-240	240:120	2:1	1.0
468-277	277:120	2.31:1	1.0
468-288	288:120	2.4:1	0.75
468-300	300:120	2.5:1	0.75
468-346	346:120	2.88:1	0.75
*468-480	*480:120	4:1	0.50
*468-600	*600:120	5:1	0.40

Frequency:
60Hz

Standard Secondary Voltage:
120 Volts

Insulation Level:
600 Volts, 10kV BIL full wave

Accuracy Class:
0.6 W. 1.2 x 60Hz

Thermal Rating:
150VA at 30°C amb
100VA at 55°C amb

Approvals



Model 460

- Terminals are brass studs No. 10-32 with one lockwasher, flatwasher and regular nut.
- The core and coil assembly is encased in a thermoplastic shell and filled with resin.
- These transformers are designed for operation line-to-line. They may also be operated line-to-ground or line-to-neutral at reduced voltage, (58% of rated volts).
- It is desirable to use a 1.6 amp fuse in the secondary to protect the transformer.
- With two exceptions these transformers are ANSI C57.13 group 1. Those marked * are group 2.
- Models designed specifically for 50Hz operation are available with reduced performance - consult factory for details.
- This page contains a circle diagram for the estimation of the errors for other than rated burdens. See page 9 in this section for a description of its use.
- Each transformer has two plastic terminal covers.
- Approximate weight: 7.75 lbs

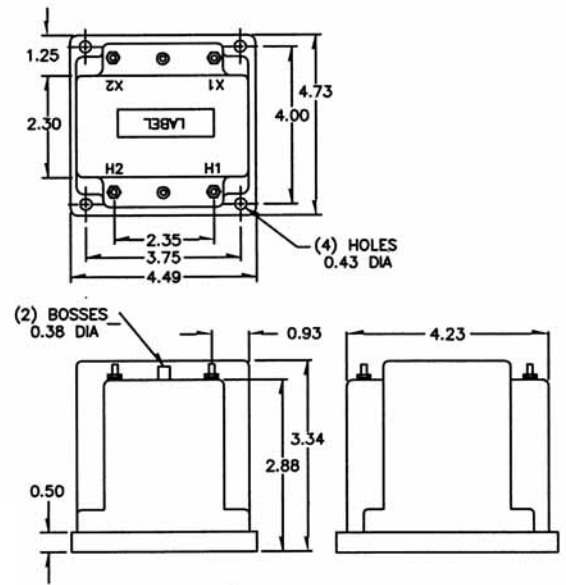
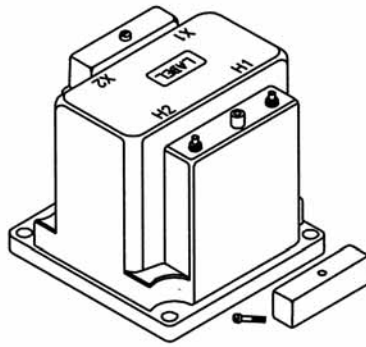

VOLTAGE TRANSFORMER CIRCLE DIAGRAM
THIS GRAPH IS DRAWN FOR 60Hz P.F. SYSTEM LOAD

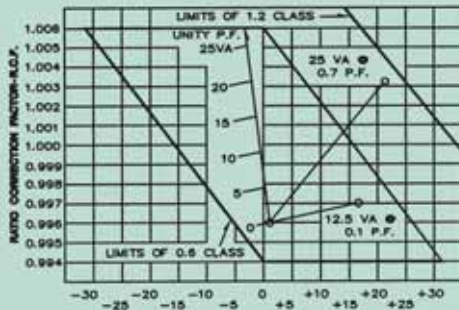

Catalogue Number	Voltage Rating	Turns Ratio	Rec. Primary Fuse Rating
460-069	69.3:120	0.58:1	5.0
460-120	120:120	1:1	4.0
460-208	208:120	1.73:1	2.0
460-240	240:120	2:1	2.0
460-277	277:120	2.31:1	2.0
460-288	288:120	2.4:1	1.5
460-300	300:120	2.5:1	1.5
460-346	346:120	2.88:1	1.5
*460-480	*480:120	4:1	1.0
*460-600	*600:120	5:1	0.75

Model 475

- The primary and secondary terminals are No. 8 brass screws with flat washer and lockwasher.
- The core and coil assembly is encased in a thermoplastic shell and filled with resin.
- These transformers are designed for operation line-to-line. They may also be operated line-to-ground or line-to-neutral at reduced voltage, (58% of rated volts).
- It is desirable to use a 3.0 amp BBS type or equal fuse in the secondary to protect the transformer.
- With two exceptions these transformers are ANSI C57.13 group 1. Those marked * are group 2.
- Models designed specifically for 50Hz operation are available with reduced performance – consult factory for details.
- This page contains a circle diagram for the estimation of the errors for other than rated burdens. See page 9 in this section for a description of its use.
- Transformer has a plastic terminal cover.
- Approximate weight: 12.5 lbs

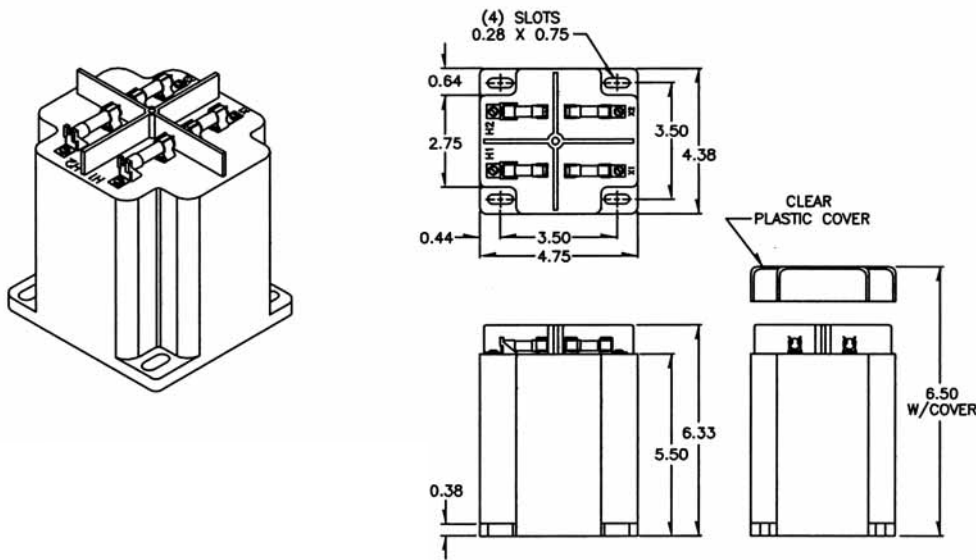

Catalogue Numbers			Voltage Rating	Turns Ratio	Rec. Primary Fuse Rating
Not Fused	Primary Fuses Only	Primary & Secondary Fuses			
475-069	475-069F	475-069FF	69.3:120	0.58:1	10.0
475-120	475-120F	475-120FF	120:120	1:1	6.0
475-208	475-208F	475-208FF	208:120	1.73:1	4.0
475-240	475-240F	475-240FF	240:120	2:1	4.0
475-277	475-277F	475-277FF	277:120	2.31:1	4.0
475-288	475-288F	475-288FF	288:120	2.4:1	3.0
475-300	475-300F	475-300FF	300:120	2.5:1	3.0
475-346	475-346F	475-346FF	346:120	2.88:1	3.0
*475-480	*475-480F	*475-480FF	*480:120	4:1	2.0
*475-600	*475-600F	*475-600FF	*600:120	5:1	1.5

Frequency:
60Hz

Standard Secondary Voltage:
120 Volts

Insulation Level:
600 Volts, 10kV BIL full wave

Accuracy Class:
0.3 W. 0.6 x 1.2M at 60Hz

Thermal Rating:
300VA at 30°C amb
200VA at 55°C amb

Approvals



VOLTAGE TRANSFORMER CIRCLE DIAGRAM
THIS GRAPH IS DRAWN FOR 60Hz P.F. SYSTEM LOAD

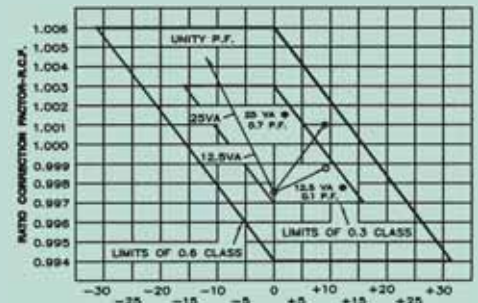

Frequency:
60Hz

Standard Secondary Voltage:
120 Volts Line

Insulation Level:
600 Volts, 10kV BIL full wave

Accuracy Class:
0.3 W, X, M & Y 1.2Z
@0.3 W, 0.6 X, M & Y

Thermal Rating:
750VA at 30°C amb
500VA at 55°C amb

Approvals



Model 450

- The primary and secondary terminals are No. 10-32 screws into 3/8" deep brass inserts and fitted with one lockwasher and flatwasher and are contained in a sealable terminal cover.
- The core and coil assembly is encased in a thermoplastic shell and filled with resin.
- These transformers are designed for operation line-to-line. They may also be operated line-to-ground or line-to-neutral at reduced voltage, (58% of rated volts).
- It is desirable to use an 8.0 amp BBS type or equal fuse in the secondary to protect the transformer.
- With two exceptions these transformers are ANSI C57.13 group 1. Those marked * are group 2.
- Model designed specifically for 50Hz operation are available with reduced performance - consult factory for details.
- Fuse blocks containing type KTK-R (class CC) fuses can be fitted.
- When primary fuses are requested, the ratings will be as given in the table below.
- This page contains a circle diagram for the estimation of the errors for other than rated burdens. See page 9 in this section for a description of its use.
- When only one fuse is used, it must be connected into the line side (H1) terminal wiring. This will prevent the presence of voltage at the H1 terminal for a ruptured fuse in the neutral (H2) terminal wiring for line-to-neutral connected transformers.
- Approximate weight: 25 lbs

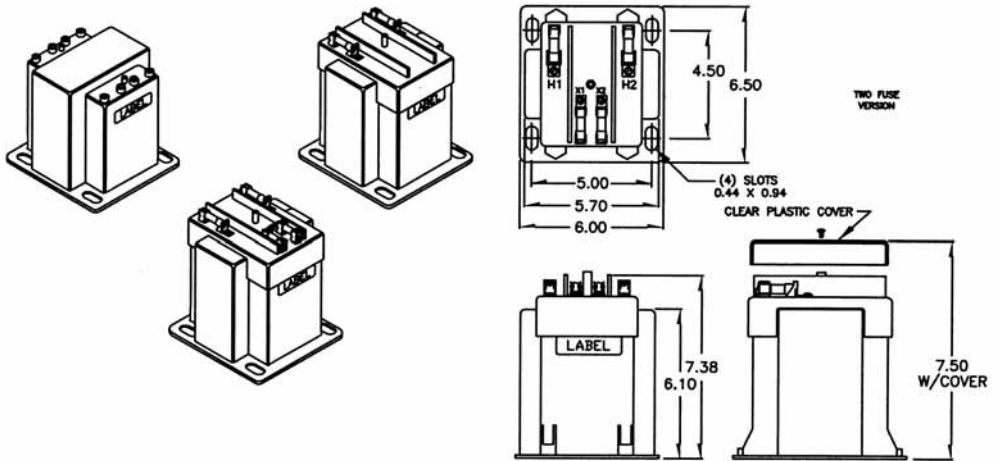

VOLTAGE TRANSFORMER CIRCLE DIAGRAM
THIS GRAPH IS DRAWN FOR 60Hz P.F. SYSTEM LOAD

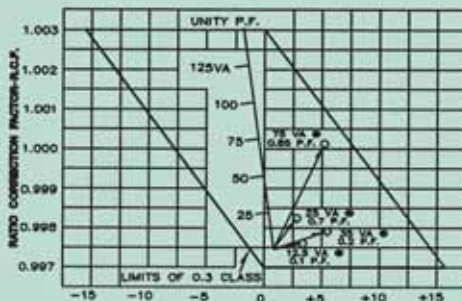

Catalogue Numbers			Voltage Rating	Turns Ratio	Rec. Primary Fuse Rating
Not Fused	Primary Fuses Only	Primary & Secondary Fuses			
@450-069	450-069F	450-069FF	69.3:120	0.58:1	15.0
@450-120	450-120F	450-120FF	120:120	1:1	10.0
450-208	450-208F	450-208FF	208:120	1.73:1	8.0
450-240	450-240F	450-240FF	240:120	2:1	8.0
450-277	450-277F	450-277FF	277:120	2.31:1	8.0
450-288	450-288F	450-288FF	288:120	2.4:1	6.0
450-300	450-300F	450-300FF	300:120	2.5:1	6.0
450-346	450-346F	450-346FF	346:120	2.88:1	5.0
*450-480	*450-480F	*450-480FF	*480:120	4:1	4.0
*450-600	*450-600F	*450-600FF	*600:120	5:1	3.0

Retro Fit Fuse Kit Order No. 0222 PL 7019

Model 2VT469

- The core and coil assembly is encased in a thermoplastic shell and filled with resin.
- These transformers are designed for operation line-to-line. They may also be operated line-to-ground or line-to-neutral at reduced voltage, (58% of rated volts).
- Terminals are No. 6-32 screws with one lockwasher and one flatwasher.
- It is desirable to use a 0.40 amp fuse in the secondary to protect the transformer.
- With two exceptions these transformers are ANSI C57.13 group 1. Those marked * are group 2.
- Models designed specifically for 50Hz operation are available with reduced performance - consult factory for details.
- Model 469 is an assembly of two transformers in one case with all terminals accessible, for open delta connection.
- Each transformer has a clear plastic terminal cover.
- Approximate weight: 4.5 lbs

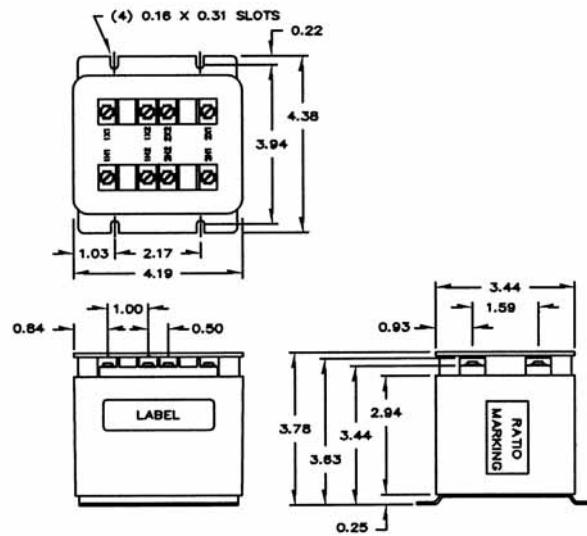
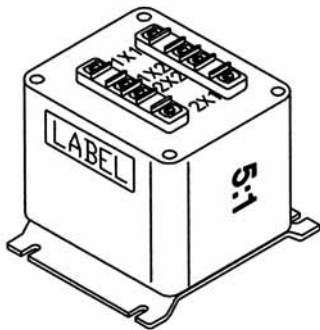

469 CONNECTION DIAGRAM

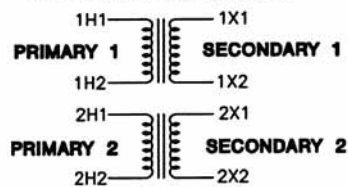

Catalogue Number	Voltage Rating	Turns Ratio	Rec. Primary Fuse Rating
469-069	69.3:120	0.58:1	1.5
469-120	120:120	1:1	1.0
469-208	208:120	1.73:1	0.5
469-240	240:120	2:1	0.5
469-277	277:120	2.31:1	0.5
469-288	288:120	2.4:1	0.4
469-300	300:120	2.5:1	0.4
469-346	346:120	2.88:1	0.4
*469-480	*480:120	4:1	0.25
*469-600	*600:120	5:1	0.25

Frequency:

60Hz

Standard Secondary Voltage:

120 Volts

Insulation Level:

600 Volts, 10kV BIL full wave

Accuracy Class:

3% at all burdens up to 5VA at 1.0 and 0.95 P.F.

Thermal Rating:

40VA at 30°C amb
27VA at 55°C amb

Approvals



Frequency:
60Hz

Standard Secondary Voltage:
120 Volts Line-to-neutral

Insulation Level:
600 Volts, 10kV BIL full wave

Accuracy Class: (Per Phase)
0.6 W. 1.2 x 60Hz

Thermal Rating: (Per Phase)
150VA at 30°C amb
100VA at 55°C amb

Approvals



Model 3VTN460

For line-to-neutral connection

- The model 3VTN460 is an assembly of three transformers in one case.
- The primary and secondary terminals are No. 8-32 screws into 1/2" deep brass inserts and fitted with one lockwasher and flatwasher.
- The core and coil assembly is encased in a thermoplastic shell and filled with resin.
- These transformers are designed for operation line-to-neutral.
- Spacing between live parts per U.L. 1558.
- Primary fuses are current limiting, 200kA interrupting capacity, incorporating a rejection feature, typically (class CC) KTK-R type.
- It is desirable to use a 1.6 amp BBS type or equal fuse in the secondary to protect the transformer.
- The transformer has a clear plastic terminal cover.
- Only ground N/n terminals if source is 3-phase, 4-wire effectively grounded.
- See page 3 of this section for a circle diagram for the estimation of the errors for other than rated burdens.
- See page 8 in this section for a description of its use.
- Approximate weight: 24 lbs.

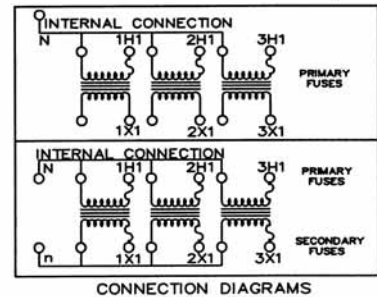
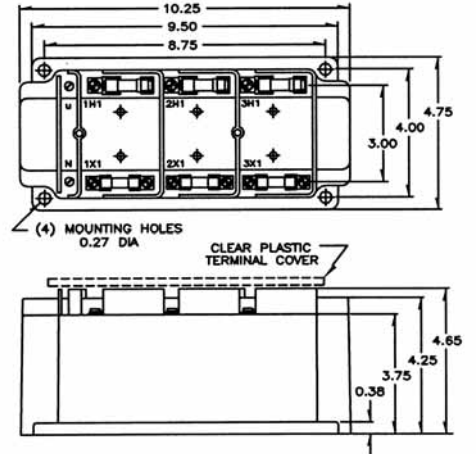
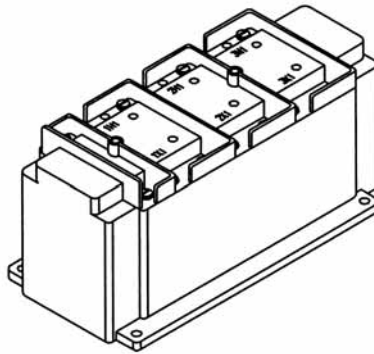

CONNECTION DIAGRAMS

Catalogue Numbers		Voltage Rating	Primary & Turns Ratio	Line to Neutral Rec. Primary Fuse Rating
Primary Fuses Only	Secondary Fuses			
3VTN460-069F*	3VTN460-069FF*	69.3:120	0.58:1	5.0
3VTN460-120F*	3VTN460-120FF*	120:120	1:1	4.0
3VTN460-240F*	3VTN460-240FF*	240:120	2:1	2.0
3VTN460-277F*	3VTN460-277FF*	277:120	2.31:1	2.0
3VTN460-300F*	3VTN460-300FF*	300:120	2.5:1	1.5
3VTN460-346F*	3VTN460-346FF*	346:120	2.88:1	1.5

* Fuse Ordering

Insert F after primary voltage rating for primary fuses, insert F after primary voltage rating for primary and secondary fuses.

Model 2VTL460

For line-to-line connection

- The model 3VTL460 is an assembly of three transformers in one case.
- The primary and secondary terminals are No. 8-32 screws into 1/2" deep brass inserts and fitted with one lockwasher and flatwasher.
- The core and coil assembly is encased in a thermoplastic shell and filled with resin.
- These transformers are designed for operation line-to-line. All terminals are accessible.
- Spacing between live parts per U.L. 1558.
- The transformer has a clear plastic terminal cover.
- See page 3 of this section for a circle diagram for the estimation of the errors for other than rated burdens.
- See page 8 in this section for a description of its use.
- Approximate weight: 24 lbs

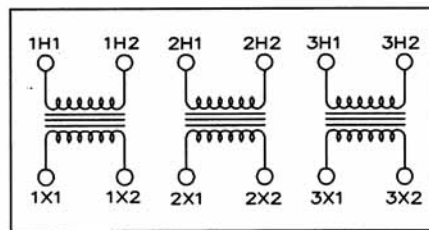
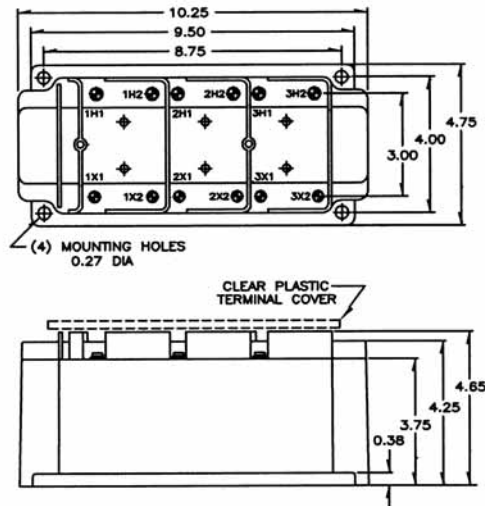
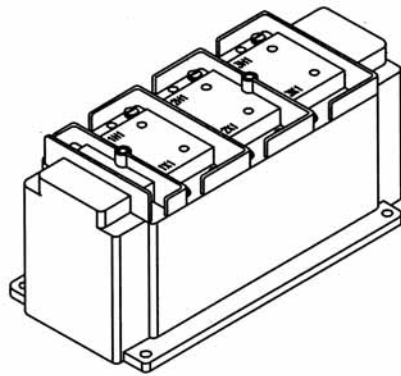

CONNECTION DIAGRAM

Catalogue Number	Voltage Rating	Turns Ratio	Rec. Primary Fuse Rating
3VTL460-120	120:120	1:1	4.0
3VTL460-208	208:120	1.73:1	2.0
3VTL460-240	240:120	2:1	2.0
3VTL460-288	288:120	2.4:1	1.5
3VTL460-480	480:120	4:1	1.0
3VTL460-600	600:120	5:1	0.75

Frequency:
60Hz

Standard Secondary Voltage:
120 Volts Line-to-Line

Insulation Level:
600 Volts, 10Kv BIL full wave

Accuracy Class:
0.6 W, 1.2 X at 60Hz

Thermal Rating:
150VA at 30°C amb
100VA at 55°C amb

Approvals



Circle Diagram Method for The Estimation of Voltage Transformer Accuracy Classes

The accuracy of a voltage transformer is a function of the algebraic and vectorial summation of the no load (or excitation) losses and the burden voltage drop. The elements of these losses at rated voltage can be conveniently estimated by means of a circle diagram, drawn with axes expressed in 0.001 unit steps vertically to represent Ratio Correction Factor and 3.44 minutes of arc horizontally to represent Phase Angle. To use the diagram for a specific voltage transformer, it is necessary to ascertain the elements of RCF and phase angle for no load and with one burden of known volt ampere rating and power factor. When these elements are plotted on the diagram with a line joining them, the errors for any other burden VA and power factor can be estimated, within the scale of the diagram, by scaling volt amperes from the distance between the two loci and the power factor in angular measurement difference. It is more convenient to construct a unity power factor line, drawn from the no load error locus, at an angle equal to the power factor angle of the known burden. All the other power factor angles can be constructed from this line. The example below indicates the construction of the diagram and lists the burdens used in the Instrument Transformer Standard, ANSI C57.13.

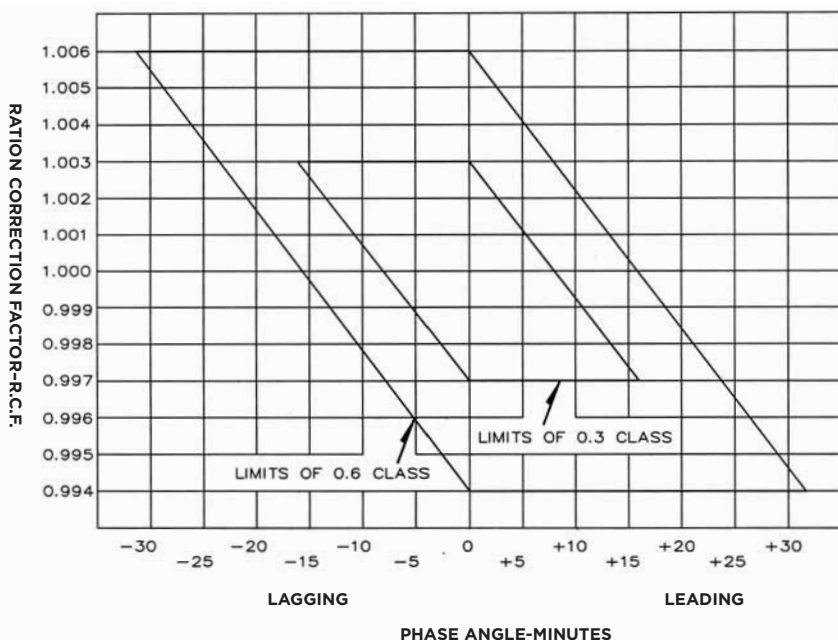
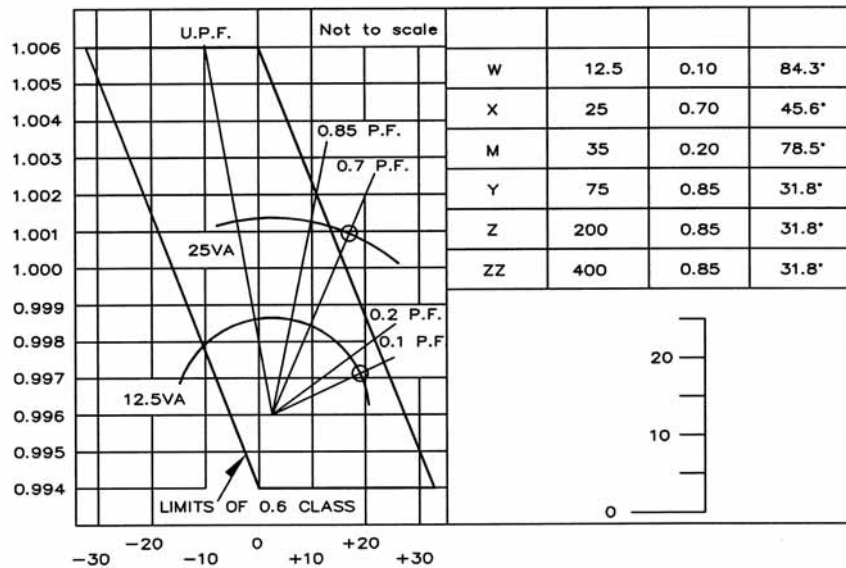

Voltage Transformers Control Power Transformers

MV Voltage Transformers
and Control Power
Transformers

Medium Voltage - 5kV

See back for Voltage Transformer Groups Contents Page

Model number Overall Size
Width x Height x Depth Voltage class

Application notes 124-125

Voltage Transformers

3PT3-60 8.94 x 8.50 x 8.50 5Kv 126



PTG3-1-60 10.85 x 7.07 x 6.38 5Kv 127
PTG3-2-60



Two fuse



One fuse

PTW3-1-60 9.31 x 8.00 x 6.38 5Kv 128-129
PTW3-2-60



Two fuse



One fuse

Control Power Transformers

CPT3-60-2 7.45 x 8.50 x 10.50 5Kv 130



Voltage Transformer Groups

Transformers for application with 100% of rated primary voltage connected to the primary terminate either line-to-line or line-to-ground. These transformers are capable of operating at 125% of rated volts in emergency conditions, but cannot have their thermal burden rating exceed 65% of rated volt amperes and 105°C Ave. winding temperature. This will result in a reduced life expectancy. Consult the factory for details. Continuous operation at 110% of rated voltage is permissible, provided that the thermal burden rated volt amperes is not exceeded.

Rated Primary Voltage for Rated System Voltage Line-To-Line	Turns Ratio	Basic Impulse Insulation Level (Kv Crest)
840 for 1455Y*	7:1	*45*
1200 for 2078Y*	10:1	*45*
2400 for 4160Y	20:1	60 or 45*
4200 for 7280Y	35:1	75
4800 for 8320Y	40:1	75
7200 for 12470Y	60:1	95 or 110
8400 for 14560Y	70:1	95 or 110
12000 for 20785Y	100:1	125 or 150
14400 for 24940Y	120:1	125 or 150

Transformers are for line-to-line connection, but may be connected line-to-neutral at a voltage of the rated line volts divided by the square root of three.

Continuous operation at 110% of rated voltage is permissible, provided that the thermal burden rated volt amperes is not exceeded.

Rated Primary Voltage for Rated System Voltage Line-To-Line	Turns Ratio	Basic Impulse Insulation Level (Kv Crest)
2400 for 2400Y	20:1	45
3300 for 3300Y*	30:1	60 or 45*
4200 for 4200Y*	35:1	60 or 45*
4800 for 4800Y	40:1	60 or 45*
7200 for 7200Y	60:1	75 or 110*
8400 for 8400Y*	70:1	75 or 110*
11000 for 11000Y	100:1	95 or 110*
12000 for 12000Y	100:1	95 or 110
13200 for 13200Y	110:1	95 or 110
14400 for 14400Y	120:1	95 or 110
18000 for 1800Y*	150:1	125*
21000 for 21000Y*	175:1	125*
24000 for 24000Y	200:1	125 or 150
27600 for 27600Y*	240:1	150 or 200
34500 for 34500Y*	300:1	150 or 200

Transformers are for line-to-ground connection, indoors only. The neutral terminal is insulated to withstand a test voltage of 10kV. They may be continuously operated at 110% of rated voltage, provided that the thermal burden rated volt amperes is not exceeded. Group 4A transformers may be operated at 125% of rated primary voltage, under emergency conditions, provided that the burden does not exceed 65% of the rated thermal burden, with a limit of 75°C temperature rise. This will result in a reduced life expectancy. Consult the factory for details.

Group 4A For Operation At 100% Rated Voltage		
Rated Primary Voltage for Rated System Voltage Line-To-Line	Turns Ratio	Basic Impulse Insulation Level (Kv Crest)
2400 for 4160 GND Y	20:1	*60 or 45*
4200 for 7200 GND Y	35:1	75
4800 for 8320 GND Y	40:1	75
7200 for 12470 GND Y	60:1	110
8400 for 14560 GND Y	70:1	110
4200 for 4160 GND Y	35:1	60 or 45
4800 for 4800 GND Y	40:1	60 or 45
7200 for 7200 GND Y	60:1	75
8400 for 8400 GND Y	70:1	75
11000 for 11000 GND Y	100:1	110
12000 for 12000 GND Y	100:1	110
13200 for 13200 GND Y	110:1	110
14400 for 14400 GND Y	120:1	110

NOTE: Voltage transformers connected line-to-ground on ungrounded system cannot be considered to be grounding transformers and must not be operated with the secondaries in closed delta because excessive currents may flow in the delta. For further details see ANSI/IEEE C57.13.

*Not recognised in ANSI/IEEE C57.13

Application Notes:

1. Delta Connected Supply Systems

When applying voltage transformers to ungrounded delta connected supply systems, the transformer must not be connected in wye with the wye-point connected to neutral ground, or ungrounded. The advent of zero sequence currents caused by a ground fault in the system will cause damage, and eventual destruction of the transformer if the fault is not removed quickly.

2. Ferroresonance

Most voltage transformers are lightly loaded, particularly when associated with watt hour metering and relaying schemes. If the voltage transformer has one primary lead grounded, and during an abnormal condition creating a large over-voltage, the transformer may saturate, and its impedance may cause a resonance with the system capacitance. This resonance, or oscillation, may be sustained and could destroy the voltage transformer. If, however, the secondaries are connected in delta, with a broken corner, and a suitable power resistor is connected across the broken corner, then ferroresonance can be damped. Our recommendation for the resistive value is shown on the catalogue sheet where it applies. The power rating is determined by the use.

3. Secondary Circuit Check

Immediately prior to connecting the burden and leads to the transformer, a check of the impedance of that circuit should be made. This will avoid a possible short-circuit connection to the transformer. If a short-circuit is applied to the transformer, it can be withstood for one second.

NOTE: Only secondary circuit fuses can adequately protect the transformer from such a short circuit.

4. Primary Fuse Rating

Values shown are suggested for normal installations, in order to protect the system from a voltage transformer failure. Higher ratings at users option, may be used to avoid unusual clearing due to conditions resulting from magnetising in-rush.

Voltage Class	No. of Bushings	Connection	LV 1 Min 60Hz	H2 1 Min 60Hz	HV 1 Min 60Hz	Induced 18 Sec, 400Hz
	1	L-GND N	2.5kV	10kV	NA	15kV or 19kV
5kV	2	L-L	2.5kV	NA	15kV or 19kV	Double Voltage
	1	L-GND N	2.5kV	10kV	NA	26kV
8.7kV	2	L-L	2.5kV	NA	26kV	Double Voltage
	1	L-GND N	2.5kV	10kV	NA	34kV
15kV	2	L-L	2.5kV	NA	34kV or 36kV	Double Voltage
	1	L-GND N	2.5kV	10kV	NA	50kV
25kV	2	L-L	2.5kV	NA	50kV	Double Voltage
	1	L-GND N	2.5kV	10kV	NA	70kV
34.5kV	2	L-L	2.5kV	NA	70kV or 80kV	Double Voltage

Routine Factory Tests include: Polarity, accuracy, and partial discharge per CANADIAN STANDARDS (CAN3-C13-M83)

(Partial discharge tests can also be carried out to IEC requirements on request)

ANSI BURDEN DATA

Burden	VA	Power Factor	Angle
W	12.5	0.10	84.3*
X	25	0.70	45.6*
M	35	0.20	78.5*
Y	75	0.85	31.8*
Z	200	0.85	31.8*
ZZ	400	0.85	31.8*

Application:
60Hz

Standard Secondary Voltage:
120 Volts

Maximum System Voltage:
5.6kV, 60kV BIL full wave

Accuracy Class:
0.3WX, 0.6M, 1.2Y at 100% rated voltage with 120V based.

Thermal Rating:
700VA total, 350VA per phase at 30°C amb.
450VA total, 225VA per phase at 55°C amb.
Weight:
Approximately: 38 lbs

Approvals



Model 3PT3-60

- Primary terminals are No. 10-32 brass screws with one flatwasher and lockwasher.
- The core and coil assembly is encased in a plastic enclosure and vacuum encapsulated in polyurethane resin.
- The transformers are tested for partial discharge to Canadian Standards CAN 3-C13-M83. This test can also be carried out to IEC requirements if requested.
- Recommended Spacing is for guidance only. The user needs to set appropriate values to assure performance for: high potential test; impulse test; high humidity; partial discharge; high altitude.

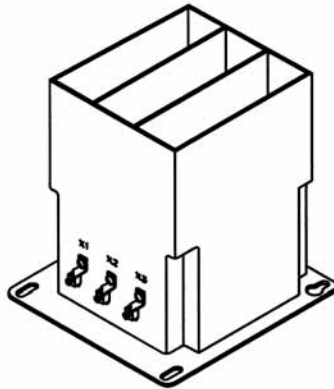

RECOMMENDED SPACING
A=CASE TO GROUND=1.50" MIN.

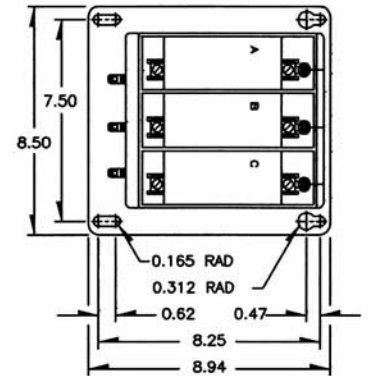
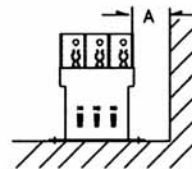

Group	Catalogue No. Fuses	Catalogue No. Fuse Clips Only	Rated Primary Voltage	Ratio	Suggested Fuse Rating**
1	3PT3-60-841FFF	3PT3-60-841CCC	840	7:1	1.0E
1	3PT3-60-122FFF	3PT3-60-122CCC	1200	10:1	1.0E
1	3PT3-60-242FFF	3PT3-60-242CCC	2400	20:1	0.5E
2	*3PT3-60-332FFF	*3PT3-60-332CCC	3300	30:1	0.5E
2	3PT3-60-422FFF	3PT3-60-422CCC	4200	35:1	0.5E
2	3PT3-60-482FFF	3PT3-60-482CCC	4800	40:1	0.5E

*Rated 50/60Hz, 0.3W, 500 VA Total @ 30°C, 350 VA Total @ 55°C.

** SEE PAGE Primary Fuse Rating
Fuse is 0.81" Diameter, 5.62" long.

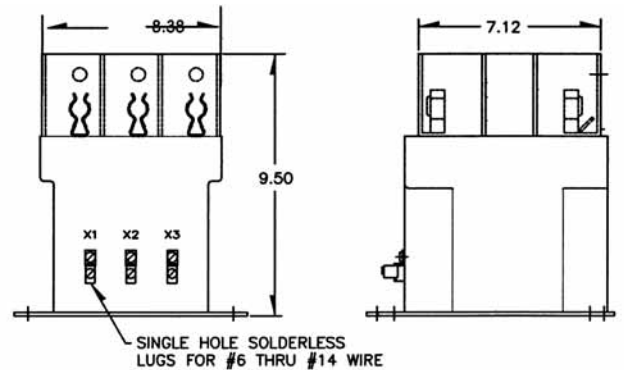
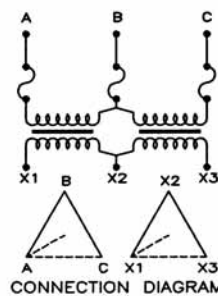

Models PTG3-1-60 and PTG3-2-60

- Primary terminals that are unfused are 1/4-20 brass screws with one flatwasher and lockwasher.
- Primary terminals that are fused are 1/4-20 brass screws with one flatwasher and lockwasher and two nuts.
- Secondary terminals are No. 10-32 brass screws with one flatwasher and lockwasher.
- The transformers are tested for partial discharge to Canadian Standards CAN 3-C13-M83. This test can also be carried out to IEC requirements if requested.
- The core and coil assembly is encased in a plastic enclosure and vacuum encapsulated in polyurethane resin.
- Thermal burden rating is for 120 Volt secondaries.
- Plated steel mounting base.
- Fuses have 1" Dia Caps and 5" clip centres.
- Switchgear style is similar to fused style. No fuse or fuse clip is provided, but inserts for fuse clips are supplied.

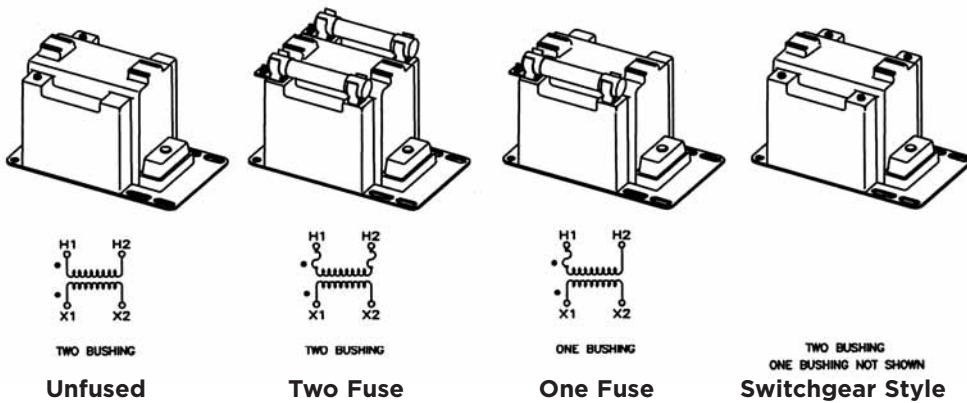

Frequency:
60Hz

Maximum System Voltage:
5.6kV, 60kV BIL full wave

Accuracy Class:
0.3 WXY, 0.6M, 1.2Z at 100% rated voltage with 120V based ANSI burden.
0.3 WX, 0.6M, 1.2 Y at 58% rated voltage with 69.3V based ANSI burden.

Thermal Rating:
750VA total 30°C amb
500VA 55°C amb

Weight:
Approximately 34 lbs, unfused

Approvals



Group	Two Bushing (a)			Catalogue Numbers			
	Primary Voltage	Ratio	Secondary Voltage	Unfused	Fuses	Fuse Clips Only (d)	Switchgear Style
1	*2400	20:1	120	PTG3-2-60-242	PTG3-2-60-242FF	PTG3-2-60-242CCS or CCL	PTG3-2-60-242SS
2	3300	30:1	110-50Hz	PTG3-2-60-332	PTG3-2-60-332FF	PTG3-2-60-332CCS or CCL	PTG3-2-60-332SS
2	*4200	35:1	120	PTG3-2-60-422	PTG3-2-60-422FF	PTG3-2-60-422CCS or CCL	PTG3-2-60-422SS
2	*4800	40:1	120	PTG3-2-60-482	PTG3-2-60-482FF	PTG3-2-60-482CCS or CCL	PTG3-2-60-482SS

Group	One Bushing (b)			R FR (C)	Catalogue Numbers		
	Primary Voltage	Ratio	Secondary Voltage		Fuses	Fuse Clips Only (d)	Switchgear Style
4A	*2400	20:1	120	230	PTG3-1-60-242F	PTG3-1-60-242CS or CL	PTG3-1-60-242S
4B	*4200	35:1	120	230	PTG3-1-60-422F	PTG3-1-60-422CS or CL	PTG3-1-60-422S
4B	*4800	40:1	120	230	PTG3-1-60-482F	PTG3-1-60-482CS or CL	PTG3-1-60-482S

- Two fuse transformers should not be used for Y connections. It is preferred practice to connect one lead from each voltage transformer directly to the neutral terminal, using a fuse in the line side of the primary only. By using this connection a transformer can never be made "live" from the line side by reason of a blown fuse in the neutral side. For continuous operation the transformer primary voltage should not exceed 110% of rated value.
- Voltage transformers connected line-to-ground cannot be considered to be grounding transformers and must not be operated with the secondaries in closed delta because excessive currents may flow in the delta.
- See page 1, item 2 for ferroresonance considerations. Values in table are in ohms.
- Fuse clips noted as "CCS" or "CS" accept fuses with 1" Dia. caps and 5" clip centres. Fuse clips noted as "CCL" or "CL" accept fuses with 1.63" Dia, caps and 5.88" clip centres.

NOTE: It is recommended the system line-to-line voltage not exceed the transformer maximum system voltage level.

PTG3-1-60 PTG3-2-60

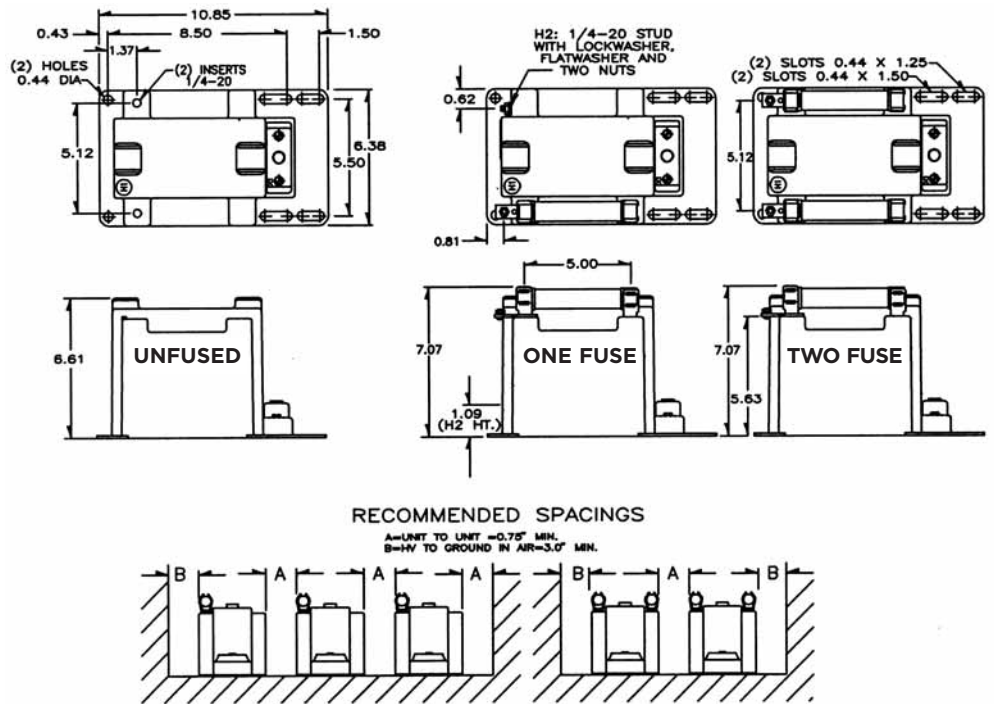

Recommended spacings are for guidance only. User needs to set appropriate values to assure performance for: high potential test; impulse test; high humidity; partial discharge; high altitude; and other considerations like configuration.

Fuse For Model PTG3 Transformer	Rating Volts	Interrupting Amperes (Sym)	Suggested Rating* Continuous Amperes	Cap Dia. Inches	Length Inches	Clip Centres Inches
2400:120V	5.5kV	45,000	2.0E	1.0	5.63	5.00
3300:110V	5.5kV	45,000	2.0E	1.0	5.63	5.00
4200:120V	5.5kV	45,000	1.0E	1.0	5.63	5.00
4800:120V	5.5kV	45,000	1.0E	1.0	5.63	5.00

The circle diagram can be used to predict the performance of a transformer for various loads and power factors. A convenient scale of volt amperes is shown on the unity power factor line (u.p.f.) and commences at the zero or no-load locus. To use the diagram, measure the known V.A. and scribe an arc about the "zero" locus of a length that contains the angle of the burden power factor. The point at which the arc terminates is the error locus in phase angle minutes and ratio correction factor.

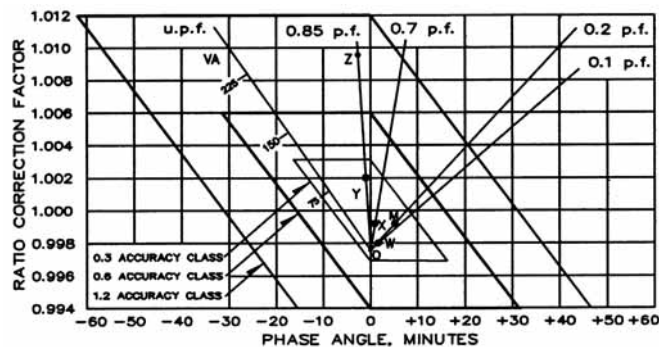

Circle Diagram

Models PTW3-1-60 and PTW3-2-60

- Primary terminals that are unfused are 1/4-20 brass screws with one flatwasher and lockwasher.
- Primary terminals that are fused are 1/4-20 brass screws with one flatwasher and lockwasher and two nuts.
- Secondary terminals are No. 10-32 brass screws with one flatwasher and lockwasher.
- The transformers are tested for partial discharge to Canadian Standards CAN 3-C13-M83. This test can also be carried out to IEC requirements if requested.
- The core and coil assembly is encased in a plastic enclosure and vacuum encapsulated in polyurethane resin.
- Thermal burden rating is for 120 Volt secondaries.
- Plated steel mounting base.
- Fuses have 1" Dia Caps and 5" clip centres.
- Switchgear style is similar to fused style. No fuse or fuse clip is provided, but inserts for fuse clips are supplied.

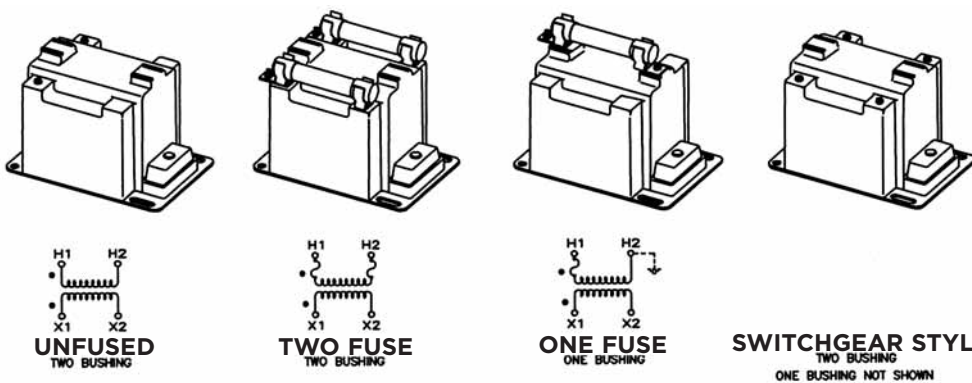

Frequency:
60Hz

Standard Secondary Voltage:
120 Volts

Maximum System Voltage:
5.6kV, 60kV BIL full wave

Accuracy Class:
0.3 WXY, 1.2Z at 100% rated voltage with 120V based ANSI burden. 0.6 WX, 1.2MY at 58% rated voltage with 69.3V based ANSI burden.

Thermal Rating:
750VA total 30°C amb
500VA 55°C amb

Weight:
Approximately 34 lbs, unfused

Approvals



Group	Two Bushing (a)			Catalogue Numbers			
	Primary Voltage	Ratio	Secondary Voltage	Unfused	Fuses	Fuse Clips Only (d)	Switchgear Style
1	*2400	20:1	120	PTG3-2-60-242	PTG3-2-60-242FF	PTG3-2-60-242CC Sor CCL	PTG3-2-60-242SS
2	3300	30:1	110-50Hz	PTG3-2-60-332	PTG3-2-60-332FF	PTG3-2-60-332CCS or CCL	PTG3-2-60-332SS
2	*4200	35:1	120	PTG3-2-60-422	PTG3-2-60-422FF	PTG3-2-60-422CCS or CCL	PTG3-2-60-422SS
2	*4800	40:1	120	PTG3-2-60-482	PTG3-2-60-482FF	PTG3-2-60-482CCS or CCL	PTG3-2-60-482SS

Group	One Bushing (b)			R FR (C)	Catalogue Numbers		
	Primary Voltage	Ratio	Secondary Voltage		Fuses	Fuse Clips Only (d)	Switchgear Style
4A	*2400	20:1	120	230	PTG3-1-60-242F	PTG3-1-60-242CS or CL	PTG3-1-60-242S
4B	*4200	35:1	120	230	PTG3-1-60-422F	PTG3-1-60-422CS or CL	PTG3-1-60-422S
4B	*4800	40:1	120	230	PTG3-1-60-482F	PTG3-1-60-482CS or CL	PTG3-1-60-482S

- Two fuse transformers should not be used for Y connections. It is preferred practice to connect one lead from each voltage transformer directly to the neutral terminal, using a fuse in the line side of the primary only. By using this connection a transformer can never be made "live" from the line side by reason of a blown fuse in the neutral side. For continuous operation the transformer primary voltage should not exceed 110% of rated value.
- Voltage transformers connected line-to-ground cannot be considered to be grounding transformers and must not be operated with the secondaries in closed delta because excessive currents may flow in the delta.
- See page 1, item 2 for ferroresonance considerations. Values in table are in ohms.
- Fuse clips noted as "CCS" or "CS" accept fuses with 1" Dia. caps and 5" clip centres. Fuse clips noted as "CCL" or "CL" accept fuses with 1.63" Dia, caps and 5.88" clip centres.

NOTE: It is recommended the system line-to-line voltage not exceed the transformer maximum system voltage level.

PTW3-1-60 PTW3-3-60

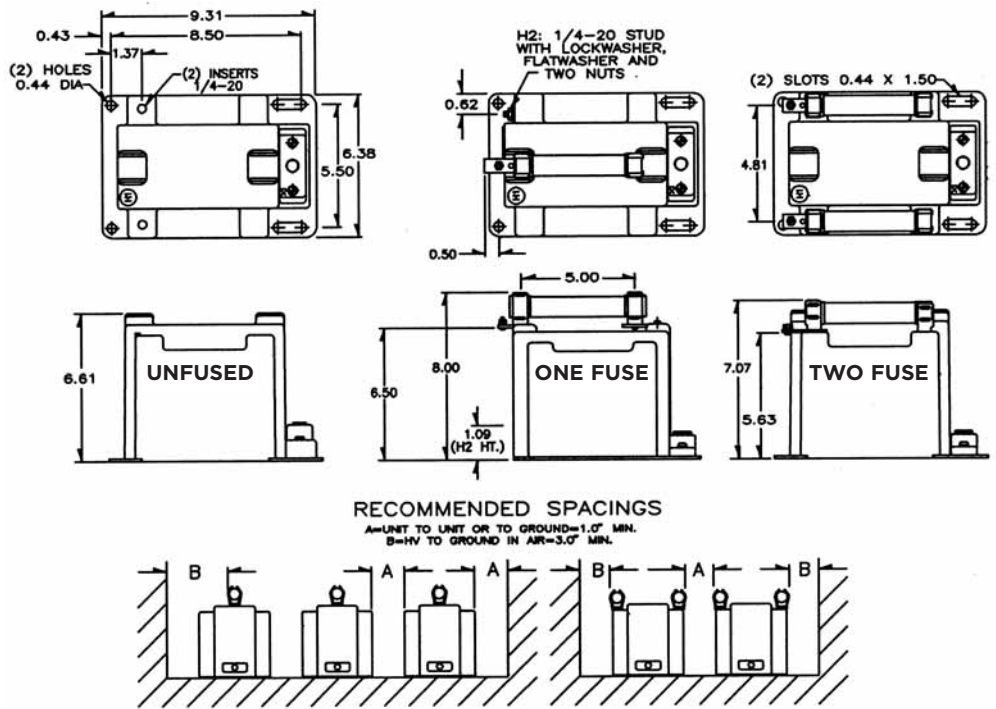

Recommended spacings are for guidance only. User needs to set appropriate values to assure performance for: high potential test; impulse test; high humidity; partial discharge; high altitude; and other considerations like configuration.

Fuse for Model PTW3 Transformer	Rating Volts	Interrupting Amperes (Sym)	Suggested Rating* Continuous Amperes	Cap Dia. Inches	Length Inches	Clip Centres Inches
2400:120V	5.5kV	45,000	2.0E	1.0	5.63	5.00
3300:110V	5.5kV	45,000	2.0E	1.0	5.63	5.00
4200:120V	5.5kV	45,000	1.0E	1.0	5.63	5.00
4800:120V	5.5kV	45,000	1.0E	1.0	5.63	5.00

The circle diagram can be used to predict the performance of a transformer for various loads and power factors. A convenient scale of volt amperes is shown on the unity power factor line (u.p.f.) and commences at the zero or no-load locus. To use the diagram, measure the known V.A. and scribe an arc about the "zero" locus of a length that contains the angle of the burden power factor. The point at which the arc terminates is the error locus in phase angle minutes and ratio correction factor.

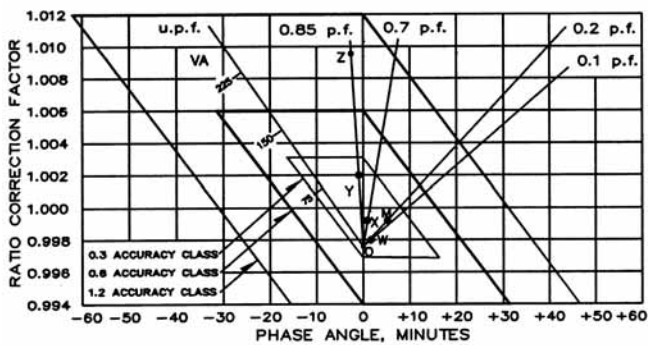

Circle Diagram

Technical Data

Contents	Page
Applicable Standards/Accuracy Classes	130
Current Transformer Burden Data	131
Current Transformer Relaying Accuracy/ Voltage Transformer Burden Data	132
Current Transformer Ration Modification	133
Primary Turn/Secondary Turn Ratio Modification Application Guide	136/137
Current Transformer/ Window Size Table for Ratio Correction	139

Applicable Standards/Accuracy Classes

Standards

- I. Current Transformers
 - a. I.E.E./A.N.S.I. Publication C57.13-1993
 - b. I.E.C. Publication No. 185
 - c. British Standard Publication BS 3938
- II. Voltage Transformers
 - a. I.E.E./A.N.S.I. Publication C57.13-1993
 - b. I.E.C. Publication No. 186
 - c. British Standard Publication BS 3941

There are too many standards to list them all. Those listed are the ones we most commonly see. It should be understood that standards are not laws but, are suggested guidelines for users and manufacturers alike. The standards usually suggest test and testing procedures, as well.

The following is based on U.S.A. standards (C57.13-1993) which is the standard of choice in the U.S.A.

I.E.C. (International Electrotechnical Commission) is the standard of choice of the international community.

Current Transformers

Accuracy and Burden – Accuracy is defined for two different types of applications (metering and relaying).

The following table defines metering accuracy classes.

Standard Accuracy Classes

The limits of transformer correction factor in standard shall be as shown in table.

Metering Accuracy Class	Voltage Transformers (At 100% Rated Voltage)		Current Transformers			
	Ratio Correction Factors					
	Minimum	Maximum	At 100% Rated Current*		At 10% Rated Current	
Minimum			Maximum	Minimum	Maximum	
0.3	0.997	1.003	0.997	1.003	0.994	1.006
0.6	0.994	1.006	0.994	1.006	0.988	1.012
1.2	0.988	1.012	0.988	1.012	0.976	1.024

*For current transformers the 100% rated current limit also applies to the current corresponding to the continuous thermal current rating factor.

Accuracy statement (0.3, 0.6, 1.2) is not complete unless it is stated at a given burden. The following table defines the standard burdens for metering and relaying as well.

Current Transformer Burden Data

Standard Burdens for Current Transformers with 5A Secondary Windings*

Burdens	Burden Designation**	Resistance ()	Inductance (mH)	Impedance ()	Volt Amperes (At 5A)	Power Factor
Metering burdens	B-0.10.09	0.116	0.1	2.5	0.9	
	B-0.20.18	0.232	0.2	5.0	0.9	
	B-0.50.45	0.580	0.5	12.5	0.9	
	B-0.90.81	1.040	0.9	22.5	0.9	
	B-1.81.62	2.080	1.8	45.0	0.9	
Relaying burdens	B-10.50	2.300	1.0	25.0	0.5	
	B-21.00	4.600	2.0	50.0	0.5	
	B-42.00	9.200	4.0	100.0	0.5	
	B-84.00	18.400	8.0	200.0	0.5	

* If a current transformer secondary winding is rated at other than 5A, ohmic burdens for specification and rating shall be derived by multiplying the resistance and inductance of the table $[5/(\text{ampere rating})]^2$, the VA at rated current, the power factor, and the burden designation remaining the same.

** These standard burden designations have no significance at frequencies other than 60Hz.

There is another factor which must be considered, that is, phase error. The following table gives the maximum acceptable phase error associated with the standard accuracy classes.

Accuracy Classes	± Phase Error at 100% Primary Current	± Phase Error at 100% Primary Current
0.3	15 Minutes	30 Minutes
0.6	30 Minutes	60 Minutes
1.2	60 Minutes	120 Minutes

In summary, if you have a metering accuracy statement of "0.3 B0.5" it means the following: (0.3) maximum ratio error of 0.3% of 100% of rated primary current or 30.6% ratio error at 10% of rated primary current. With a maximum phase error of 315 minutes at 100% rated primary current or 330 minutes maximum phase error at 10% of rated primary current. All of the above is based on a burden of (B0.5) 0.5 OHMS at power factor of 0.9.

Current Transformers Relaying Accuracy

All relaying accuracies are 310% maximum ratio error when there is 20 times current flowing in the CT secondary (20 x 5A=100A). There are two designations, which are "C" and "T". Designations "C" stands for "Calculate" this type of CT's performance can be very accurately calculated. The "T" designation stands for "Test". This type of CT's performance must be verified by testing.

The following table gives the relaying accuracy designations:

Designation	Burden	Power Factor	Secondary Voltage
C10 or T100	0.1ff	0.5	10V
C20 or T200	0.2ff	0.5	20V
C50 or T500	0.5ff	0.5	50V
C100 or T100	1.0ff	0.5	100V
C200 or T200	2.0ff	0.5	200V
C400 or T400	4.0ff	0.5	400V
C800 or T800	8.0ff	0.5	800V

Voltage Transformers Burden Data

Voltage transformers have the same accuracy classes as indicated in Table 1 (i.e. 0.3, 0.6 and 1.2). These accuracy classes must be given at a stated burden in order to be meaningful. The following table gives the standard burden data:

Burden	Volt Amperes	Power Factor	P.F. Angle
W	12.5	0.10	84.3°
X	25	0.70	45.6°
M	35	0.20	78.5°
Y	75	0.85	31.8°
Z	200	0.85	31.8°
ZZ	400	0.85	31.8°

In summary if you have a "0.6Y" accuracy and burden statement this means: (0.6) maximum ratio error of +0.6% at a burden of 75VA with a power factor of 0.85.

Current Transformers Ratio Modification

Relatively large changes in ratio may be achieved through the use of primary turns, for example:

CT Ratio	Number of Primary Turns	Modified Ratio
100:5A	2	50:5A
200:5A	2	100:5A
300:5A	2	150:5A
100:5A	3	33.3:5A
200:5A	3	66.6:5A
300:5A	3	100:5A
100:5A	4	25:5A
200:5A	4	50:5A
300:5A	4	75:5A

A primary turn is the number of times the primary conductor passes through the CT's window. The main advantage of this ratio modification is you maintain the accuracy and burden capabilities of the higher ratio. The higher the primary rating the better the accuracy and burden rating.

You can make smaller ratio modification adjustments by using additive or subtractive secondary turns. For example if you have a CT with a ratio of 100:5A. By adding one additive secondary turn the ratio modification is 105:5A, by adding on subtractive secondary turn the ratio modification is 95:5A. Subtractive secondary turns are achieved by placing the "X1" lead through the window from the H1 side and out the H2 side. Additive secondary turns are achieved by placing the "X1" lead through the window from the H2 and out the H1 side. So, when there is only one primary turn each secondary turn modifies the primary rating by 5 amperes. If there is more than one primary turn each secondary turn value is changed (i.e. 5A divided by 2 primary turns = 2.5A). The following table illustrates the effects of different combinations of primary and secondary turns:

CT Ratio 100:5A

Primary Turns	Secondary Turns	Ratio Adjustment
1	-0-	100:5A
1	1+	105:5A
1	1-	95:5A
2	-0-	50:5A
2	1+	52.5:5A
2	2-	45.0:5A
3	-0-	33.3:5A
3	1+	34.97:5A
3	1-	31.63:5A

In summary, with the use of primary/secondary turns it is possible to modify any CT ratio. Since low ratio CT's generally have poorer performance characteristics and high ratio CT's have better performance. By using added primary/secondary turns you can modify a higher ratio CT to have a lower ratio and enjoy the better performance of the higher ratio.

Use This Table To Determine Size Window Needed for Number and Primary Conductor(s)

Window Diameter												
Insulation Type RHW	AWG MCM	1/2"	3/4"	1"	1 1/2"	2"	2 1/2"	3	3 1/2"	4"	5"	6"
	14	3	6	10	25	41	58	90	121	155	-	-
	12	3	5	9	21	35	50	77	103	132	-	-
	10	2	4	7	18	29	41	64	86	110	-	-
	8	1	2	4	9	16	22	35	47	60	94	137
	6	1	1	2	6	11	15	24	32	41	64	93
	4	1	1	1	5	8	12	18	24	31	50	72
	3	1	1	1	4	7	10	16	22	38	44	63
	2	-	1	1	4	6	9	14	19	24	38	56
	1	-	1	1	3	5	7	11	14	18	29	42
	0	-	1	1	2	4	6	9	12	16	25	37
	00	-	-	1	1	3	5	8	11	14	22	32
	000	-	-	1	1	3	4	7	9	12	19	28
	0000	-	-	1	1	2	4	6	8	10	16	24
	250	-	-	-	1	1	3	5	6	8	13	19
	300	-	-	-	1	1	3	4	5	7	11	17
	350	-	-	-	1	1	2	4	5	6	10	15
	400	-	-	-	1	1	1	3	4	6	9	14
	500	-	-	-	1	1	1	3	4	5	8	11
	600	-	-	-	1	1	1	2	3	4	6	9
	700	-	-	-	1	1	1	1	3	3	6	8
	750	-	-	-	-	1	1	1	3	3	5	8

Burden

Burden is the opposition to the flow of current from the transformers secondary. Burden may be expressed in terms of resistance or volt amperes. The following table may be used to convert volt ampere values to resistance values for 5 amp secondary CT's:

Volt Ampere (VA)	Resistance (Ω OHMS)
0.5	0.02
1.0	0.04
1.5	0.05
2.0	0.08
2.5	0.10
3.0	0.12
3.5	0.14
4.0	0.16
4.5	0.18
5.0	0.20
5.5	0.22
6.0	0.24
6.5	0.26
7.0	0.28

Volt Ampere (VA)	Resistance (Ω OHMS)
7.5	0.30
8.0	0.32
8.5	0.34
9.0	0.36
9.5	0.38
10.0	0.40
12.5	0.50
15.0	0.60
20.0	0.80
25.0	1.00
45.0	1.80
50.0	2.00
75.0	3.00
100.0	4.00

Primary Turn Ratio Modification Application Guide

The nameplate of the current transformer is based on the condition that the primary conductor will be passed once through the transformer opening. The rating can be reduced in even multiples by looping this conductor two or more times through the opening. A transformer having a rating of 200 to 5 amperes will be changed to 50 to 5 amperes if four loops or turns are made with the primary cable as illustrated.

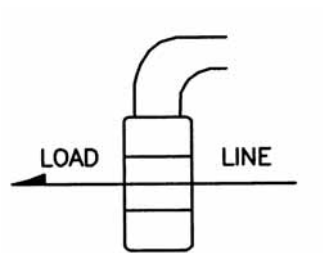

1 Primary Turn

Nameplate Ratio	Actual Ratio
100:5	100:5
150:5	150:5
200:5	200:5
300:5	300:5
400:5	400:5
500:5	500:5
600:5	600:5
800:5	800:5

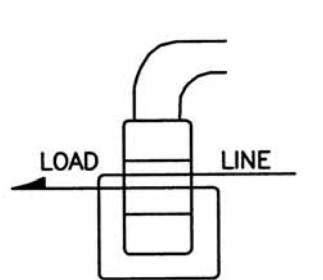

2 Primary Turns

Nameplate Ratio	Actual Ratio
100:5	50:5
150:5	75:5
200:5	100:5
300:5	150:5
400:5	200:5
500:5	250:5
600:5	300:5
800:5	400:5

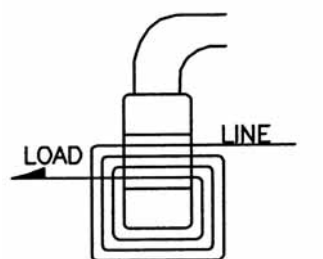

4 Primary Turns

Nameplate Ratio	Actual Ratio
100:5	25:5
150:5	37.5:5
200:5	50:5
300:5	75:5
400:5	100:5
500:5	125:5
600:5	150:5
800:5	200:5

Secondary Turn Ratio Modification Application Guide

Formula:
$$\frac{I_p}{I_s} = \frac{N_s}{N_p}$$

Where: I_p - Primary Amperage
 I_s - Secondary Amperage
 N_p - Number of Primary Turns
 N_s - Number of Secondary Turns

Example: A 300:5 Current Transformer -

$$\frac{300p}{5s} = \frac{60s}{1p}$$

(In practicality one turn is dropped from the secondary as a ratio correction factor.)

The ratio of the current transformer can be modified by altering the number of secondary turns by forward or backwinding the secondary lead through the window of the current transformer.

By adding secondary turns the same primary amperage will result in a decrease in secondary output. By subtracting secondary turns the same primary amperage will result in greater secondary output.

Again using the 300:5 example adding five secondary turns will require 325 amps on the primary to maintain the 5 amp secondary output or

$$\frac{325p}{5s} = \frac{65s}{1p}$$

Deducting 5 secondary turns will only require 275 amps on the primary to maintain the 5 amp secondary output or

$$\frac{275p}{5s} = \frac{55s}{1p}$$

The above ratio modifications are achieved in the following manner:

To add secondary turns, the white lead should be wound through the CT from the side opposite the polarity mark.

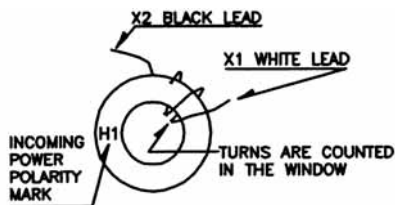

To subtract secondary turns the white lead should be wound through the CT from the same side as the polarity mark.

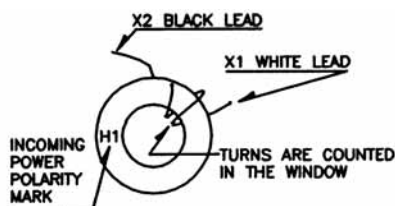

Current Transformer Window Size

Model	Current Ratio	Windows (inches)
13	500 TURNS	0.56
13	1000 TURNS	0.56
13	2000 TURNS	0.56
14*	50:5 THRU 100:5	0.50
15sft	50:5 THRU 200:5	0.94
16*	50:5 THRU 400:5	1.25
63A	50:5 THRU 100:5	0.56
63B	50:5 THRU 300:5	1.25
63C	50:5 THRU 600:5	2.00
1A	50:5 THRU 250:5	0.64
1B	50:5 THRU 250:5	0.64
2RL	50:5 THRU 300:5	1.05
2SFT	50:5 THRU 400:5	1.13
2SHT	50:5 THRU 300:5	1.13
2DRL	50:5 THRU 300:5	1.00
5RL	50:5 THRU 500:5	1.56
5RL	600:5 THRU 1200:5	1.56
5SFT	50:5 THRU 500:5	1.56
5SFT	600:5 THRU 1200:5	1.56
5SHT	50:5 THRU 500:5	1.56
5SHT	600:5 THRU 1200:5	1.56
5DRL	50:5 THRU 500:5	1.56
5DRL	600:5 THRU 1200:5	1.56
56SFT	50:5 THRU 500:5	2.06
56SFT	600:5 THRU 1200:5	2.06
56RL	50:5 THRU 500:5	2.06
56RL	600:5 THRU 1200:5	2.06
6SFT	100:5 THRU 600:5	2.06
6SFT	750:5 THRU 1500:5	2.06
6RL	100:5 THRU 600:5	2.06
6RL	750:5 THRU 1500:5	2.06
6SHT	100:5 THRU 600:5	2.06
6SHT	750:5 THRU 1500:5	2.06
7SFT	100:5 THRU 800:5	2.50
7SFT	1000:5 THRU 1600:5	2.50
7SHT	100:5 THRU 800:5	2.50
7SHT	1000:5 THRU 1600:5	2.50
7RL	100:5 THRU 800:5	2.50
7RL	1000:5 THRU 1600:5	2.50
76SFT	200:5 THRU 800:5	3.00
76SFT	1000:5 THRU 1800:5	3.00
76SFT	2000:5	3.00
76RL	200:5 THRU 800:5	3.00
76RL	1000:5 THRU 1800:5	3.00
76RL	2000:5	3.00
2DARL	50:5 THRU 300:5	1.00
5ARL	50:5 THRU 500:5	1.56
5ARL	600:5 THRU 1200:5	1.56
5ASFT	50:5 THRU 500:5	1.56
5ASFT	600:5 THRU 1200:5	1.56
5ASHT	50:5 THRU 100:5	1.56
5ASHT	600:5 THRU 1200:5	1.56
5DARL	50:5 THRU 100:5	1.56

Model	Current Ratio	Windows (inches)
5DARL	750:5 THRU 1000:5	1.56
10SFT	50:5 THRU 600:5	1.56
6ARL		
6ASHT		
6ASFT	100:5 THRU 600:5	2.06
6ARL		
6ASHT		
6ASFT	750:5 THRU 1500:5	2.06
7ASFT	50:5 THRU 600:5	2.50
7ASFT	750:5 THRU 1600:5	2.50
7ASHT	50:5 THRU 600:5	2.50
7ASHT	750:5 THRU 1600:5	2.50
7ARL	50:5 THRU 600:5	2.50
7ARL	750:5 THRU 1600:5	2.50
8SHT	200:5 THRU 1000:5	3.25
8SHT	1200:5 THRU 1500:5	3.25
8SHT	1600:5 THRU 2500:5	3.25
8SHT	3000:5	3.25
8SHT	3200:5 THRU 4000:5	3.25
8RL	200:5 THRU 1000:5	3.25
8RL	1200:5 THRU 1500:5	3.25
8RL	1600:5 THRU 2500:5	3.25
8RL	3000:5	3.25
8RL	3200:5 THRU 4000:5	3.25
19SHT	300:5 THRU 600:5	4.25
19SHT	750:5 THRU 1200:5	4.25
19SHT	1500:5 THRU 2000:5	4.25
19SHT	2500:5 THRU 3000:5	4.25
19RL	300:5 THRU 600:5	4.25
19RL	750:5 THRU 1200:5	4.25
19RL	1500:5 THRU 2000:5	4.25
19RL	2500:5 THRU 3000:5	4.25
21	50:5 THRU 300:5	1.25
21	400:5 THRU 600:5	1.25
21	750:5 THRU 1000:5	1.25
22	100:5 THRU 500:5	1.63
23	100:5 THRU 600:5	2.00
24	100:5 THRU 800:5	2.50
24	1000:5 THRU 1200:5	2.50
24	1500:5 THRU 1600:5	2.50
25	200:5 THRU 800:5	3.13
25	1000:5 THRU 1200:5	3.13
25	1500:5 THRU 2000:5	3.15
64	50:5 THRU 500:5	1.56
65	50:5 THRU 600:5	2.00
66	750:5 THRU 1500:5	2.00
100	50:5 THRU 800:5	2.50
100	200:5 THRU 600:5	4.00
100	800:5	4.00
100	1000:5 THRU 1200:5	4.00
100	1500:5 THRU 2000:5	4.00
100	2500:5 THRU 3000:5	4.00
110	200:5 THRU 600:5	4.00
110	800:5	4.00
110	1000:5 THRU 1200:5	4.00
110	1500:5 THRU 2000:5	4.00

*Contact factory for availability

Model	Current Ratio	Windows (inches)
110	2500:5 THRU 3000:5	4.00
112	50:5 THRU 600:5	2.25
112	750:5 THRU 1200:5	2.25
113	50:5 THRU 600:5	2.75
113	750:5 THRU 1500:5	2.75
114	50:5 THRU 800:5	3.25
114	1000:5 THRU 1600:5	3.25
115	50:5 THRU 1000:5	4.00
115	1200:5 THRU 2000:5	4.00
115	2500:5 THRU 3200:5	4.00
115MR	600:5MR	4.00
115MR	1200:5MR	4.00
115MR	2000:5MR	4.00
117	50:5 THRU 1200:5	4.62
117	1500:5 THRU 2500:5	4.62
117	3000:5 THRU 4000:5	4.62
117MR	600:5MR	4.62
117MR	1200:5MR	4.62
117MR	2000:5MR	4.62
120	200:5 THRU 600:5	5.75
120	800:5	5.75
120	1000:5 THRU 1200:5	5.75
120	1500:5 THRU 2000:5	5.75
120	2500:5 THRU 3000:5	5.75
120	3500:5 THRU 4000:5	5.75
125	600:5 THRU 1200:5	6.31
125	1500:5 THRU 2000:5	6.31
125	2500:5 THRU 3000:5	6.31
125	3500:5 THRU 4000:5	6.31
126	400:5 THRU 1200:5	8.25
126	1500:5 THRU 2000:5	8.25
126	2500:5 THRU 3000:5	8.25
126	3200:5 THRU 4000:5	8.25
126	5000:5	8.25
130	200:5 THRU 600:5	5.75
130	800:5	5.75
130	1000:5 THRU 1200:5	5.75
130	1500:5 THRU 2000:5	5.75
130	2500:5 THRU 3000:5	5.75
130	4000:5	5.75
135	50:5 THRU 750:5	5.75
135	800:5 THRU 1500:5	5.75
135	1600:5 THRU 2000:5	5.75
135	2500:5 THRU 3000:5	5.75
135	3200:5 THRU 4000:5	5.75
135	5000:5	5.75
135MR	600:5MR	5.75
135MR	1200:5MR	5.75
135MR	2000:5MR	5.75
135MR	3000:5MR	5.75
135MR	4000:5MR	5.75
135MR	5000:5MR	5.75
137	50:5 THRU 600:5	5.50
137	750:5 THRU 1200:5	5.50
137	1500:5 THRU 2500:5	5.50
137	3000:5 THRU 4000:5	5.50
137	5000:5	5.50
137MR	600:5MR	5.50

Model	Current Ratio	Windows (inches)
137MR	1200:5MR	5.50
137MR	2000:5MR	5.50
137MR	3000:5MR	5.50
137MR	4000:5MR	5.50
137MR	5000:5MR	5.50
139	50:5 THRU 600:5	6.50
139	750:5 THRU 1600:5	6.50
139	2000:5 THRU 3000:5	6.50
139	3200:5 THRU 4000:5	6.50
139	5000:5	6.50
139MR	600:5MR	6.50
139MR	1200:5MR	6.50
139MR	2000:5MR	6.50
139MR	3000:5MR	6.50
139MR	4000:5MR	6.50
139MR	5000:5MR	6.50
140	50:5 THRU 600:5	8.13
140	800:5	8.13
140	1000:5 THRU 1200:5	8.13
140	1500:5 THRU 2000:5	8.13
140	2500:5 THRU 3000:5	8.13
140	4000:5	8.13
140	5000:5	8.13
140	6000:5	8.13
140MR	600:5 MR	8.13
140MR	1200:5 MR	8.13
140MR	2000:5MR	8.13
140MR	3000:5MR	8.13
140MR	4000:5MR	8.13
140MR	5000:5MR	8.13
141	50:5 THRU 600:5	8.13
141	800:5	8.13
141	1000:5 THRU 1200:5	8.13
141	1500:5 THRU 2000:5	8.13
141	2500:5 THRU 3000:5	8.13
141	4000:5	8.13
141	5000:5	8.13
141	6000:5	8.13
141MR	600:5MR	8.13
141MR	1200:5MR	8.13
141MR	2000:5MR	8.13
141MR	3000:5MR	8.13
141MR	4000:5MR	8.13
141MR	5000:5MR	8.13
142	50:5 THRU 600:5	7.25
142	750:5 THRU 800:5	7.25
142	1000:5 THRU 1200:5	7.25
142	1500:5 THRU 3000:5	7.25
142	3200:5 THRU 4000:5	7.25
142	5000:5 THRU 6000:5	7.25
142MR	600:5MR	7.25
142MR	1200:5MR	7.25
142MR	2000:5MR	7.25
142MR	3000:5MR	7.25
142MR	4000:5MR	7.25
142MR	5000:5MR	7.25
143	50:5 THRU 600:5	7.31
143	750:5 THRU 800:5	7.31

Model	Current Ratio	Windows (inches)
143	1000:5 THRU 1200:5	7.31
143	1500:5 THRU 3000:5	7.31
143	3200:5 THRU 4000:5	7.31
143	5000:5 THRU 6000:5	7.31
143MR	600:5MR	7.31
143MR	1200:5MR	7.31
143MR	2000:5MR	7.31
143MR	3000:5MR	7.31
143MR	4000:5MR	7.31
143MR	5000:5MR	7.31
144	50:5 THRU 600:5	6.00
144	750:5 THRU 800:5	6.00
144	1000:5 THRU 1200:5	6.00
144	1500:5 THRU 3000:5	6.00
144	3200:5 THRU 4000:5	6.00
144	5000:5 THRU 6000:5	6.00
144MR	600:5MR	6.00
144MR	1200:5MR	6.00
144MR	2000:5MR	6.00
144MR	3000:5MR	6.00
144MR	4000:5MR	6.00
144MR	5000:5MR	6.00
145	50:5 THRU 600:5	6.00
145	750:5 THRU 800:5	6.00
145	1000:5 THRU 1200:5	6.00
145	1500:5	6.00
145	1600:5 THRU 3000:5	6.00
145	3200:5 THRU 4000:5	6.00
145	5000:5 THRU 6000:5	6.00
145MR	600:5MR	6.00
145MR	1200:5MR	6.00
145MR	2000:5MR	6.00
145MR	3000:5MR	6.00
145MR	4000:5MR	6.00
145MR	5000:5MR	6.00
170	200:5 THRU 600:5	4.25
170	750:5 THRU 800:5	4.25
170	1000:5 THRU 1200:5	4.25
170	1500:5 THRU 2000:5	4.25
170	2500:5 THRU 3000:5	4.25
170	3500:5 THRU 4000:5	4.25
191	100:5 THRU 400:5	1.25
192	100:5 THRU 500:5	1.75
193	100:5 THRU 600:5	2.13
194	100:5 THRU 800:5	2.50
194	1000:5 THRU 1200:5	2.50
194	1500:5 THRU 1600:5	2.50
195	200:5 THRU 800:5	3.06
195	1000:5 THRU 1200:5	3.06
195	1500:5 THRU 2000:5	3.06
296	50:5 THRU 400:5	1.50
296	500:5 THRU 1000:5	1.50
297	50:5 THRU 600:5	2.25
298	50:5 THRU 800:5	3.00
299	50:5 THRU 800:5	3.38
300	50:5 THRU 1000:5	3.75
300	1200:5 THRU 2000:5	3.75
3P40	100:5 THRU 150:5	1.75

Model	Current Ratio	Windows (inches)
3P40	200:5 THRU 250:5	1.75
3P40	300:5 THRU 500:5	1.75
3P41	100:5 THRU 200:5	2.03
3P41	250:5 THRU 400:5	2.03
3P41	500:5 THRU 600:5	2.03
3P42	100:5 THRU 300:5	2.50
3P42	400:5 THRU 800:5	2.50
3P42	1000:5 THRU 1600:5	2.50
3P43	200:5 THRU 600:5	3.00
3P43	800:5 THRU 1200:5	3.00
3P43	1500:5 THRU 2000:5	3.00
3P80	100:5 THRU 300:5	1.00
3P81	100:5 THRU 500:5	1.63
3P82	300:5 THRU 600:5	2.00
3P83	50:5 THRU 250:5	1.55 x 0.45
3P83	300:5 THRU 800:5	1.55 x 0.45
3P84	100:5 THRU 400:5	2.05 x 0.50
3P84	500:5 THRU 800:5	2.05 x 0.50
3P84	1000:5 THRU 1200:5	2.05 x 0.50
3P86	50:5 THRU 250:5	1.55 x 0.25
3P86	300:5 THRU 800:5	1.55 x 0.25
3P90	50:5 THRU 500:5	1.63
3P90	600:5 THRU 1000:5	1.63
3P91	100:5 THRU 500:5	2.12
3P91	600:5 THRU 1200:5	2.12
3P92	100:5 THRU 750:5	2.56 x 2.12
3P92	800:5 THRU 1500:5	2.56 x 2.12
3P92	1600:5 THRU 2500:5	2.56 x 2.12
3P93	200:5 THRU 800:5	2.88
3P93	1000:5 THRU 2000:5	2.88
196*	100:5 THRU 400:5	1.25
197*	400:5 THRU 800:5	3.12
197*	1000:5 THRU 1200:5	3.12
197*	1500:5 THRU 2000:5	3.12
682	50:5 THRU 600:5	7.62
682	750:5 THRU 1500:5	7.62
682	1600:5 THRU 3000:5	7.62
682	4000:5	7.62
780	50:5 THRU 600:5	6.50
780	750:5 THRU 1500:5	6.50
780	1600:5 THRU 3000:5	6.50
780	3200:5 THRU 4000:5	6.50
781	600:5MR	6.50
781	1200:5MR	6.50
781	2000:5MR	6.50
781	3000:5MR	6.50
781	4000:5MR	6.50
785	50:5 THRU 600:5	6.50
785	750:5 THRU 1500:5	6.50

Model	Current Ratio	Windows (inches)
785	1600:5 THRU 2500:5	6.50
786	3000:5 THRU 4000:5	6.50
786	600:5MR	6.50
786	1200:5MR	6.50
786	2000:5MR	6.50
786	3000:5MR	6.50
786	4000:5MR	6.50
778	50:5 THRU 600:5	6.50
778	750:5 THRU 1500:5	6.50
778	1600:5 THRU 3000:5	6.50
778	3200:5 THRU 4000:5	6.50
778	5000:5	6.50
20-2	1:5 THRU 25:5	N/A
20-2	30:5 THRU 40:5	N/A
20-2	50:5	N/A
20-4	1:5 THRU 25:5	N/A
20-4	30:5	N/A
20-4	40:5	N/A
20-4	50:5	N/A
20X	5:0.100 THRU 15.000	N/A
20X	1:5 THRU 10.5:5	N/A
20X	0.500:1 THRU 0.400:10	N/A
20X	SUM 2	N/A
20X	SUM 3	N/A
20X	SUM 4	N/A
20X	SUM 5	N/A
190-2	1:5 THRU 25:5	N/A
190-2	30:5	N/A
190-2	40:5	N/A
190-2	50:5	N/A
190-4	1:5 THRU 25:5	N/A
190-4	30:5	N/A
190-4	40:5	N/A
190-4	50:5	N/A
190X	5:0.100 THRU 15.000	N/A
190X	1:5 THRU 10.5:5	N/A
190X	0.500:1 THRU 0.400:10	N/A
190X	SUM 2	N/A
190X	SUM 3	N/A
190X	SUM 4	N/A
190X	SUM 5	N/A
189*	2.5:5 THRU 40.5	N/A
189*	50:5 THRU 100.5	N/A
188X*	5:0.100 THRU 5:15.000	N/A
188X*	1.500:5 THRU 10.000:5	N/A
188X*	0.500:1 THRU 0.400:10	N/A
188X*	SUM 2 THRU SUM 3	N/A
188X*	SUM 4 THRU SUM 5	N/A
188X*	SUM 6	N/A
467	0.58 THRU 2.4:1	N/A
467	2:5 THRU 5:1	N/A
467	3:17:1 50 Hz	N/A
468*	0.58 THRU 2.4:1	N/A
468*	2:5 THRU 5:1	N/A
468*	3:17:1 50 Hz	N/A
460*	0.58 THRU 2.4:1	N/A
460*	2:5 THRU 5:1	N/A

Model	Current Ratio	Windows (inches)
460*	3:17:1 50 Hz	N/A
475*	0.58 THRU 2.4:1	N/A
475*	2:5 THRU 5:1	N/A
2VT469	0.58 THRU 2.4:1	N/A
2VT469	2:5 THRU 5:1	N/A
2VT469	3:17:1 50 Hz	N/A
3VTN460*	0.58 THRU 2.4:1	N/A
3VTN460*	2:5 THRU 5:1	N/A
3VTN460*	3:17:1 50 Hz	N/A
3VTL460*	1:1 THRU 2.4:1	N/A
3VTL460	4:1 THRU 5:1	N/A
450*	0.58 THRU 2.4:1	N/A
450*	2:5 THRU 5:1	N/A
450*	3:17:1 50 Hz	N/A
3PT3-60	840-4800 Voltages	N/A
3PT3-60	840-4800 Voltages	N/A
PTG3-1-60	2400-4800 Voltages	N/A
PTG3-1-60	2400-4800 Voltages	N/A
PTG3-1-60	2400-4800 Voltages	N/A
PTW3-2-60	2400-4800 Voltages	N/A
PTW3-2-60	2400-4800 Voltages	N/A
PTW3-2-60	2400-4800 Voltages	N/A
CPT3-60	300 VA 2400-7200 Voltages	N/A
CPT3-60	500 VA 2400-7200 Voltages	N/A
CPT3-60	750 VA 2400-7200 Voltages	N/A
CPT3-60	750 VA 2400-7200 Voltages	N/A
CPT3-60-1	1 KVA 2400-7200 Voltages	N/A
CPT3-60-1	1 KVA 2400-7200 Voltages	N/A
CPT3-60-2	2 KVA 2400-7200 Voltages	N/A
CPT3-60-2	2 KVA 2400-7200 Voltages	N/A
CPT3-60-3	3 KVA 2400-7200 Voltages	N/A
CPT3-60-3	3 KVA 2400-7200 Voltages	N/A

Energy Division

With 4000 employees and more than 10,000 customers world-wide, the Energy Division represents a very significant part of Tyco Electronics. Based in headquarters in Ottobrunn, near Munich, Germany, the Energy Division is a global supplier to power utilities and power industry customers, to equipment manufacturers and transport systems. These customers are served by dedicated R&D teams, sales representatives in more than 80 countries, a professional marketing organisation and 25 manufacturing sites in five continents.

All of the above information, including drawings, illustrations and graphic designs, reflects our present understanding and is to the best of our knowledge and belief correct and reliable. Users, however, should independently evaluate the suitability of each product for the desired application. Under no circumstances does this constitute an assurance of any particular quality or performance. Such an assurance is only provided in the context of our product specifications or explicit contractual arrangements. Our liability for these products is set forth in our standard terms and conditions of sale. TE logo and Tyco Electronics are trademarks. CROMPTON is a trademark of Crompton Parkinson Ltd. and is used by Tyco Electronics under licence. Profibus is a trademark of Profibus Nutzerorganisation e.v. Modbus is a trademark of Schneider Automation Inc. Other trademarks or company names used herein are the property of respective owners.

Energy Division – economical solutions for the electrical power industry: cable accessories, connectors & fittings, electrical equipment, instruments, lighting controls, insulators & insulation enhancement and surge arresters.

Tyco Electronics

Crompton Instruments Facility
1610 Cobb International Blvd, Suite 4
Kennesaw, Georgia, 30152, USA

Phone: 1-800-425-8903
Fax: 1-770-423-7194

www.cromptonusa.com
www.crompton-instruments.com

 **Tyco Electronics**
Our commitment. Your advantage.